

# Watershed Management

A Compendium for Field Practitioners

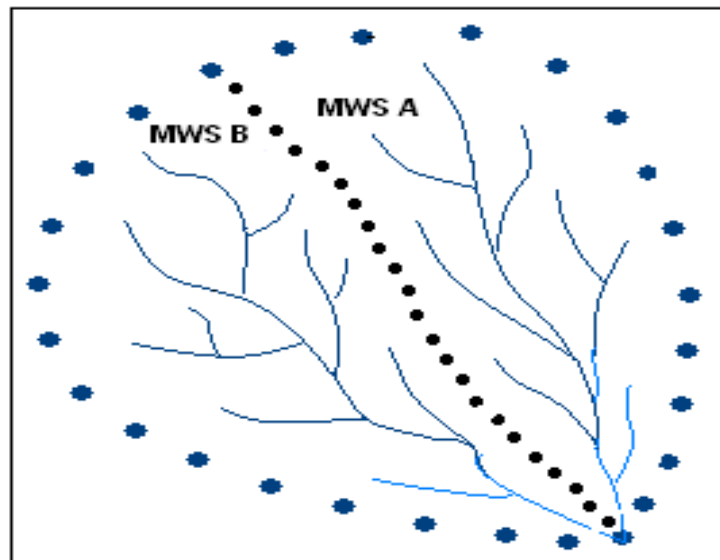

**Mihir Kumar Maitra**

## PREFACE

The approach to planning and implementation of a Watershed Development Management project may differ considerably depending upon who the implementing agency is. There are agencies who view that once the Soil and Water are developed adequately, agricultural development takes place automatically. There are yet others, who believe that organizing the beneficiary communities and building their capacity to manage their natural resources with greater participation are necessary steps to make sustainable Natural Resource Management possible. An appraisal of the successfully implemented Watershed Development projects in the country, bears the testimony that singularly neither of these approaches are sufficient but a combination of the two applied in a proper mix can produce the desired agricultural growth.

Attempt has, therefore been made in this book, to present inputs useful to field practitioners engaged in both engineering and management aspects of Watershed Management. Part I deals with technical and engineering aspects useful in developing natural resources like land, surface water, groundwater, crops and forest. Part II has been devoted to the aspects of project formulation, appraisal and implementation through participation of the beneficiary communities. The book therefore serves the purpose of a Handbook or a Compendium to those practitioners involved in planning as well as implementing Watershed Development projects.

The imperatives of managing the existing natural resources to meet our present needs without jeopardizing the needs of the future generations is gradually dawning to our conscience. Management of natural resources is the responsibility not only of those who are directly involved in utilization and subsequent degradation of the same but also with those living far away from the resource locations but causing indirect pressure through consumption practices. The challenges of natural resource management would remain as long as human being live on this Earth because everything we consume come from three basic natural resources namely plant life, animal life and minerals. Fortunately, being renewable in nature, the first two resources are amenable to judicious management practices.

## Acknowledgements

Starting my professional career as a Groundwater Geologist in Action for Food Production (AFPRO), soon it was realized that water must be considered holistically beginning from its origin i.e the rainfall and its occurrence on Watershed basis. During my next assignment in Indo-German Bilateral Project - Watershed Management (IGBP - WSM)) as a Project Engineer, I started dealing with Hydrology and various aspects of Soil and Water conservation. Mr. G.M Honore, the Project Director, became my Friend, Philosopher and Guide in broad basing my professional boundaries.

It was during my next stint at Echo Tech Services (ETS), that I started preparing both Technical and Management Plans for Watershed Development projects which were to be implemented in Madhya Pradesh and Rajasthan under International funding. My ETS colleagues Late Shri. Arun Kumar, Ms. Pritha Lal, Mr. Sanjay Dube, Ms. Moho Chaturvedi, and others enriched my understanding about the finer aspects of community based Watershed Development projects. The idea of writing a book on Watershed Management took shape during this period.

Later on while working with India Canada Environment Facility (ICEF), as a Senior Project Manager, I had the opportunity to help a dozen of project partners in formulating their proposals, release funds for their ongoing projects, monitor progress, and participate in performance evaluation. The larger part of this book was completed during this period.

However, the document would never have seen the light of the day, had there not been a chance discussion with Ms. Priya Desai, Consultant/Coordinator, India Water Portal, Arghyam, Banagaluru, who suggested that this book could be hosted in their portal. I am immensely grateful to India Water Portal for providing their portal and links to support this e-book.

**Mihir Kumar Maitra**

# CONTENTS

Page

*Preface*

*Acknowledgements*

*List of Figures*

*List of Tables*

*List of Abbreviations*

## ***Part I: Physical and Engineering Aspects***

### **Chapter 1.0 Introduction 13 - 30**

- 1.1 Natural Resources
- 1.2 Sustainable Agriculture
- 1.3 Climate Change Concerns
- 1.4 Watershed Management
- 1.5 Scope of Integration
- 1.6 Long Term Benefits
- 1.7 Need for Multi-Disciplinary Knowledge Base

### **Chapter 2.0 Watershed Hydrology 31 - 57**

- 2.1 Hydrological Cycle
- 2.2 Precipitation
- 2.3 Draught
- 2.4 Rainfall Parameters
- 2.5 Measurement of Rainfall
- 2.6 Run off
- 2.7 Estimation of Run off
- 2.8 Measurement of Stream Discharge
- 2.9 Evaporation
- 2.10 Evapo-Transpiration
- 2.11 Infiltration
- 2.12 Effective Rainfall

2.13 Water Balance

**Chapter 3.0 Groundwater and Wells 58 - 92**

- 3.1 Distribution of Subsurface water
- 3.2 Aquifer
- 3.3 Water Table
- 3.4 Groundwater Movements
- 3.5 Groundwater Development
- 3.6 Well Hydraulics
- 3.7 Well Inventory
- 3.8 Safe Yield
- 3.9 Groundwater Recharge
- 3.10 Estimation of Groundwater Recharge
- 3.11 Estimation of Groundwater Extraction
- 3.12 Recharge Structures
- 3.13 Groundwater Recharge Mechanism

**Chapter 4.0 Soil and Land Capability Class 93 - 121**

- 4.1 Importance of Soil
- 4.2 Formation of Soil
- 4.3 Composition of Soil
- 4.4 Physical Properties of Soil
- 4.5 Soil Reactions
- 4.6 Soil salinity
- 4.7 Soil Fertility
- 4.7 Classification of Soil
- 4.8 Land Capability Class
- 4.9 Land Capability Codification
- 4.10 Type of Soil Erosion
- 4.11 Preparation of LCC Map

**Chapter 5.0 Soil And Moisture Conservation 122 - 142**

- 5.1 Run-off and Erosion

- 5.2 Erosion Transportation
- 5.3 Conservation Measures
- 5.4 Vegetational Measures
- 5.5 Agronomical Practices
- 5.6 Land levelling and Field Bunds
- 5.7 Terraces
- 5.8 Gully Plugs
- 5.9 Other Minor Structures

**Chapter 6.0      Water Harvesting Structures      143 - 171**

- 6.1 In situ Water Harvesting
- 6.2 Computation of Peak Discharge
- 6.3 Surface Water Tanks
- 6.4 Over Flow Weirs
- 6.5 Stability Check of a Weir
- 6.6 Innovative Design of Weirs

**Chapter 7.0      Water Requirement of Crops      172 - 206**

- 7.1 Function of Water
- 7.2 Function of Rainfall
- 7.3 Crop Seasons
- 7.4 Principal Indian Crops
- 7.5 Crop Rotation
- 7.6 Soil Characteristics
- 7.7 Soil Water
- 7.8 Irrigation Schedule
- 7.9 Application of Irrigation Water
- 7.10 Irrigation Efficiency
- 7.11 Soil Moisture Approach
- 7.12 Duty and delta
- 7.13 Consumptive Use
- 7.14 Estimation of Effective Rainfall

**Chapter 8.0      Afforestation in Watersheds**

**207 - 239**

- 8.1 Forest and Agriculture
- 8.2 Utility of Forests
- 8.3 Classification of Forests
- 8.4 Deforestation
- 8.5 Wastelands
- 8.6 Afforestation
- 8.7 Choice of Species
- 8.8 Propagation by Seeds
- 8.9 Vegetative Propagation
- 8.10 Nursery for Plants
- 8.11 Plantation of Seedlings
- 8.12 Post Plantation Care
- 8.13 Common Causes for Poor Survival
- 8.14 Standard Plantation Practices
- 8.15 Joint Forest Management

**Chapter 9.0      Climate Variability**

**240 - 259**

- 9.1 Climate and Weather
- 9.2 Know Your Earth
- 9.3 Atmosphere
- 9.4 Monsoon
- 9.5 Temperature
- 9.6 Climate Change
- 9.7 Potential Impact of Climate Change
- 9.8 Climate Change Adaptation and Mitigation
- 9.9 International Actions
- 9.10 National Action Plan
- 9.11 Broad Based Approach
- 9.12 Disaster Management
- 9.13 Capacity Building of Communities

## ***Part II : Project Formulation and Management***

### **Chapter 10.0 Project Formulation 260 - 294**

- 10.1 Type of Project
- 10.2 Analysis of Project Elements
- 10.3 Contents of Project Proposal
- 10.4 Technical Plan
- 10.5 Size of the Project
- 10.6 Project Concerns
- 10.7 Need Assessment
- 10.8 Resource Inventory
- 10.9 Socio Economic Survey
- 10.10 Participatory Rural Appraisal

### **Chapter 11.0 Appraisal of Project Proposal 295 - 329**

- 11.1 Assessment of Project Proponent
- 11.2 Project Appraisal
- 11.3 Technical Feasibility
- 11.4 Economic Viability
- 11.5 Social desirability
- 11.6 Environmental Impact Assessment
- 11.7 Additional Requirements
- 11.8 Logical Framework Approach (LFA)
- 11.9 Project Planning Matrix
- 11.10 LFA Workshop
- 11.11 Logframe and Project Management
- 11.12 Project Launching

### **Chapter 12.0 Project Implementation, Monitoring and Evaluation 330 - 365**

- 12.1 Project Team



- 12.2 Project Management Plan
- 12.3 Entry Programme
- 12.4 Community Participation
- 12.5 Project Implementation Approach
- 12.6 Project Management Committee
- 12.7 Project Monitoring
- 12.8 Result Based Management (RBM)
- 12.9 Project Evaluation
- 12.10 Withdrawal Strategy

**Reference** **366 - 367**

Annexure I      Format for Resource Inventory in a Watershed  
for preparation of Technical Plan **368 - 371**

Annexure II      Questionnaire seeking pertinent details  
about a Voluntary Organization  
intending to implement Watershed  
Management Projects **372 - 377**

Annexure III      Conversion Table **378**

About the Author

## List of Figures

- Figure 1.1 Physiographic boundaries of a typical medium size watershed
- Figure 2.1 Symon type non-recording raingauge
- Figure 2.2 Tipping bucket in combination with non-recording raingauge
- Figure 2.3 A typical rainfall chart from a tipping bucket raingauge
- Figure 2.4 Graphical method for computing cross-sectional area of a stream
- Figure 2.5 Field layout for measuring velocity of a stream using floats
- Figure 2.6 Typical current meters for measurement of stream velocity
- Figure 2.7 A typical single-peaked hydrograph
- Figure 2.8 A modified Class A land pan evaporimeter
- Figure 2.9 Rainfall-evaporation plot (climatic water balance)
- Figure 3.1 Schematic diagram of sub-surface distribution of water
- Figure 3.2 Factors governing flow through porous medium
- Figure 3.3 Dewatering of aquifer during pumping of a tube well
- Figure 3.4 Curves showing the rates of drawdown and recovery in a well
- Figure 3.5 Optimum discharge of a tube well obtained from step drawdown test
- Figure 3.6 A thematic arrangement of Groundwater recharge structure
- Figure 3.7 Schematic representation of Groundwater recharge process
- Figure 3.8 Effects of location of Percolation Tanks in recharging Groundwater
- Figure 5.1 Typical cross-section of land with field bunds
- Figure 5.2 Cross-section of inward sloping bench terraces
- Figure 6.1 Cross section of a large earthen bund (earthen dam)
- Figure 6.2a Plan of a typical masonry overflow weir
- Figure 6.2b Cross-section of a typical masonry overflow weir
- Figure 6.3 Forces acting within the body of a masonry weir
- Figure 9.1 Know Your earth
- Figure 10.1 A typical transect of a watershed village
- Figure 10.1 Example of a Typical Problem tree
- Figure 10.2 Example of a typical Objective Tree
- Figure 11.3 A model approach to watershed management

## List of Tables

Table 2.1	Analysis of rainfall chart
Table 2.2a	Barlow's coefficient ( $K_1$ ) for type of catchments
Table 2.2b	Barlow's coefficient ( $K_2$ ) for type of rainfalls
Table 4.1	Differentiation of soil particles in major groups
Table 4.2	Texture assessment by feel and shape method
Table 4.3	Nutrient status of soil
Table 4.4	Land capability rating table
Table 4.5	Soil depth classes
Table 4.6	Land slope classes
Table 4.7	Soil erosion phases
Table 4.8	Steps showing determination of Land Capability Class
Table 5.1	Recommended spacing for field bunds in lower slope ranges
Table 5.2	Recommended dimensions of field bunds
Table 6.1	Recommended values for run off coefficients for different land use
Table 6.2	Recommended return period for design of water harvesting structures
Table 6.3	Intensity-Duration-Return period relationship, India
Table 7.1	Common Indian crops for different seasons
Table 7.2	Classification of Soil Texture
Table 7.3	Composition of a representative Soil
Table 7.4	Soil Fertility Status
Table 7.5	Chemical Reaction of Soil
Table 7.6	Depth of root zone of some matured crops
Table 7.7	Moisture contents of Soils with different Texture
Table 7.8	Irrigation Water Requirements of crops
Table 7.9	Monthly Crop Coefficient (k) for use in Blaney-Criddle formula
Table 7.10	Monthly percentage of day light hour covering India
Table 7.11	Crop Coefficient (k) for different growth period of crops
Table 7.2	Percentage of Effective Rainfall corresponding to normal Rainfall
Table 7.3	Ration of $C_u$ to Rainfall during the growing season of some crops
Table 7.4	Average monthly Consumptive use ( $C_u$ ), mm
Table 8.1	Rating of trees for their various uses
Table 8.2	Time for seed collection and sowing time of some common species

Table 8.3	Recommended spacing for some common fruit trees
Table 11.1	Standard lay out of a Project Planning Matrix
Table 12.1	Logframe for a sample WSM project following RBM approach
Table 12.2	A standard format for monitoring project Outputs

## List of Abbreviations

<b>bcm</b>	Billion Cubic Metre
<b>DANIDA</b>	Danish International Development agency
<b>FAO</b>	Food and Agricultural Organization of the United Nations
<b>FYM</b>	Farm Yard Manure
<b>GHG</b>	Green House Gas
<b>GW</b>	Groundwater
<b>IMD</b>	Indian Meteorological Department
<b>IPCC</b>	Intergovernmental Panel on Climate Change
<b>JFM</b>	Joint Forest Management
<b>Km</b>	Kilometre
<b>LFA</b>	Logical Framework Approach
<b>Mha</b>	Million Hectare
<b>Mham</b>	Million Hectare Metre
<b>mm</b>	Milli metre
<b>NRM</b>	Natural Resource Management
<b>PET</b>	Potential Evapotranspiration
<b>PIA</b>	Project Implementing Organization
<b>PPM</b>	Project Planning Matrix
<b>PRA</b>	Participatory Rural Appraisal
<b>RBM</b>	Result Based Management
<b>SHG</b>	Self Help Group
<b>VI</b>	Vertical Interval
<b>WC</b>	Watershed Committee
<b>WSD</b>	Watershed Development
<b>WSM</b>	Watershed Management

# ***1.0 Introduction***

---

## **1.1 NATURAL RESOURCES**

The sum total of all physical, chemical, biological and social factors which constitute our surroundings is our environment. Each element of these surroundings on which we survive, is a natural resource. Thus, any part of our natural environment such as land (soil), water, air, sunshine, plants, livestock, minerals etc. that we use are the basic ingredients for sustaining our lives. Natural resources are further classified as *biotic* (living) and *abiotic* (non-living) resources. All *Flora* and *Fauna* are the biotic resources and are part of environment. Ecology, on the other hand, is the study of animals and plants in their relationship within themselves in the background of their given environment. Thus, we come across terms like marine ecology, forest ecology, desert ecology, soil ecology etc. Biodiversity is the number and variety of species found within a geographical region including variability within and between species and within and between ecosystems.

Everything we physically consume or use for our welfare are derived from three basic natural resources namely plant life, animal life and minerals. While minerals are not a renewable resource, the other two are and hence are amenable to management practices. Soil (land) and water are the two primary resources which support plant lives and in turn the animal kingdom. While some resources are consumed directly by the primary consumers, the others are processed using technology to convert these in to various secondary and tertiary products. Some products are also used for market consumption as an economic activity.

However, the distribution of resources is not equal. While some people or region may have higher share of natural resources, the others survive on very little. People with more tend to over-consume causing faster depletion. Also there would be an accelerated depletion when too many people are dependent on too little resources. A situation like this will not only cause abject poverty and hunger affecting a the

current population but will also jeopardize the opportunities for future generations. The concept of sustainable development and equitable access are therefore important guiding principles followed in Natural Resource Management practices. The common concerns of resource degradation that deserve our immediate attention are:

- Soil erosion and loss of soil fertility
- Shortage of water for crop production
- Shortage of drinking water
- Groundwater depletion
- Reduction in forest cover and biomass
- Depletion of livestock productivity
- Shortage of feed and fodder for livestock
- Crop failures due to natural calamities (drought, flood etc.)

## **1.2 SUSTAINABLE AGRICULTURE**

Agriculture is the single largest sector which if mismanaged can cause rapid depletion of natural resources. Many agricultural operations cause large scale soil erosion and depletion of soil fertility. Over use of agro chemicals causes pollution of soil and water. Agriculture demands, inter alia, storage of large scale water, pumping out groundwater and use of large expanse of fertile lands competing against lands required for other uses.

The increasing pressure being exerted by farmers for more and more irrigation water is causing stress to the very foundation of agriculture. It will therefore be prudent to make agriculture such that the productivity of land and water is enhanced without depleting the health of these two vital resources.

The concept of sustainable agriculture is better understood by breaking down the entire agricultural system to its constituent sub-systems. The inter inter-relationship of these sub-systems are then analyzed in the background of the given environment (climate, infrastructure, socio-economic scenario etc.) along with the consumption and value addition practices prevailing in the area, The different sub-systems of agriculture are:

- Natural resource sub-system (land, water, forest etc)
- Human resource sub-system (labour, planning , management etc)
- Animal husbandry sub-system (cattle, goats, sheep, camels etc.)
- Crop production and processing sub-system.

These sub-systems are inter-dependant on each other. Thus, while one sub-system takes inputs causing stress to other, it also provides, at the same time, some outputs which go back to the others as inputs. For example, while the animal husbandry sub-system derive its fodder requirements from the crop sub-system, it provides inputs like draught power, transportation and manure to the crop sub-system. Similarly, when a crop is harvested to support the human resource sub-system, it is the human sub-system which nurtures the land to maintain its fertility. The harmonious fine tuning of all these sub-systems, whereby each one is balanced against the other without causing any undue degradation of any sub-systems and at the same time producing the outputs (crops and income), is viewed as sustainable agriculture.

### **1.3 Climate Change Concerns**

Global warming leading to Climate change is an impending threat to humanity as a whole. Prediction models suggest the possibility of an average rise of Global temperature by 3<sup>0</sup>C sometime by the year 2050 or the turn of the century depending on how the emission of the Green House Gasses are controlled. Erratic rainfall has the potential to change the frequency and intensity of droughts, floods, shifts in major crop areas, emergence of new pests etc. Rapid glacier melt is going to change the flow regime in the snow fed rivers. Therefore, Climate change is likely to affect our fresh water resources, agriculture, biodiversity and health amongst others. Although, the predicted average increase in temperature by 3<sup>0</sup>C by the turn of the century is still considered as an exaggeration but early signs are being increasingly discernable.

Notwithstanding the Climate change, Indian farmers have always been facing climate related uncertainties in their production activities. One thing that did not change for farmers over the past many decades is their financial distress. India is an agrarian country where nearly 70% of the population lives in rural areas and

depends directly and indirectly on agriculture for their livelihood. More than 80% of agricultural holdings in India are of the size less than 2 hectare and more than 60% of farmers operate less than 1 hectare area each. A majority of Indian farmers are engaged in subsistence farming with 0.27 hectare per capita land. More than 90% small and marginal farmers are dependent on rain for their crops.

Consequently, a large number of farmers have lost their investments raised mostly through Bank loans due to crop failures - a common reason for falling into debt trap. Inability to own a captive source of irrigation water also inculcates a great sense of helplessness. Added to this are frequent crop failures, increasing cost of inputs and insufficient market prices make agriculture unviable for most small and marginal farmers. Soil and water conservation practices harvesting soil moisture as far as possible have all the potential to safeguard farmers from crop failures due to shortage of rainfall.

#### **1.4 WATERSHED MANAGEMENT**

Starting from 1960s, concerned Government agencies in India undertook soil and water conservation activities in the catchment areas primarily to reduce siltation in the large reservoirs constructed for Irrigation and Power. Similar activities were undertaken in Drought Prone areas to support Agriculture. Over time, it was realized that involvements of local communities are required for maintenance of the smaller soil and water conservation structures. This led to an incremental shift in the implementation practices culminating to the present day concept of an approach commonly known as Integrated Watershed Management (IWSM).

Simultaneously, in another front, many Non Government Organizations (NGOs) were implementing agriculture, livelihood and other associated development projects in the country in selected poverty stricken areas under International funding. Eventually, they also arrived at the same conclusion that better results can be produced if the natural resources are managed by the beneficiary communities themselves under a comprehensive and integrated manner. In a nutshell, watershed management may be looked at as soil and water conservation practices integrated with a wide range of livelihood supporting activities implemented with active participation of the beneficiary communities. Emphasis



is also given on capacity building and formation of community institutions to enable the communities to better manage their resources.

The terms watershed management and watershed development are often considered synonymous and interchangeable. Management involves undertaking a series of functions like planning, organizing, controlling, monitoring, evaluating etc. All these functions are essential for natural resource management projects. Natural resource development, on the other hand, is understood as taking physical measures to harness the resources applying better management practices. The term development is often used from the point of view of utilization. However, unless natural resources are developed adequately, the question of their management does not arise. In reality, both development and management take place simultaneously, being linked in a cyclic *cause* and *effect* relationship with each other.

#### **1.4.1 Definition**

A watershed is defined as a topographically delineated geographical area in which the entire run off tends to converge through the existing drainage system to the common outlet of the area for subsequent disposal. One watershed is separated from another by a natural boundary known as the water divide or the ridge line. In short a watershed is an independent drainage unit.

Originating from the science of hydrology, the term watershed development has over the years acquired much wider implications. Broadly speaking, a watershed development project is an integrated approach of development and utilization of various natural resources existing within a watershed with the aim to derive equitable and sustainable benefits for the user communities.

Based on the conceptual premises adopted and emphasis given on the aspects of management and their desired outcome, several agencies have offered their own definitions. The widely accepted definitions are:

- Watershed management is the process of formulating and carrying out a course of action involving the manipulation of natural, agricultural and human resources in a watershed to provide goods and services that are desired by and suitable to the society, but under the condition that soil and

water resources are not adversely affected. Watershed management must consider the social, economic and institutional factors operating within and outside the watershed (FAO, 1987).

- Watershed management is the harmonious development and management of land and water resources within the natural boundaries of a watershed, so as to promote or produce, on a sustainable basis, abundance of plants and animals and their products and still deliver clean and controlled flow of water to the downstream (AISLUS, 1988)
- Watershed management is the process, by which an enabling environment for watershed based eco-system is established, through implementation of selected measures with an implied emphasis on Soil and Water conservation activities (DANIDA, 1996)

Each Watershed, small or big has its own quota of water received from rainfall. Conceptually, there would not have any water problem, if the people living in each watershed could manage to live with this available quantity (quota) of water. But, since, in nature (by gravity) water flows from upper reaches to lower reaches, people living in the down stream areas receive more water than their share of rainfall. People living in upper and middle reaches of a Watershed can easily enhance their share of water by adopting WSD practices to meet their domestic, agriculture and livelihood needs.

### **1.4.2 Implications**

A few assumptions are inherently associated with the planning of WSD projects which are kept in the back of the mind and may not be necessarily stated overtly.

These are:

- Beginning essentially with integrated soil, water and crop management, the process does not remain limited only to these activities. The development process also encompasses other associated activities related to livestock, tree plantation, renewable energy, drinking water, agro-processing, village

amenities, credit societies, market linkages and so on as per the need and capacity of the area.

- As resources are limited and needs are many, the available common resources are to be managed democratically by the user communities themselves with due consideration for equity and social justice, as far as possible. The issue of resource ownership becomes very important in this regard.
- In order to enable the communities to manage their natural resource base more efficiently, development of skills within the communities and creation of effective village level institutions are considered essential.
- Rural women depend heavily on natural resources in meeting their household needs like fuel, fodder, food, drinking water etc. They have a greater stake in the regeneration and conservation of the environment. Hence, women not only need to be integrated in the community programmes but also should have greater decision-making role in planning and implementation.
- Watershed development is instrumental for capacity building of the stake holders enabling them to climate proof their agriculture by adopting resilient resource utilization practices.
- Watershed development is required to generate production of goods to a level which is sufficient to meet the needs of the present generation, without unduly degrading the natural resource base to jeopardise the opportunities for the future generation.

While dealing with the management of natural resources the important questions therefore to be answered are a) who owns these resources b) who are the present users and c) if these natural resources are to be managed then who will manage them. Natural resources are finite but demands are increasing. Resources are therefore to be used efficiently which means there should be more benefits (produces and functions) per unit application of input of resources.

### 1.4.3 Watershed as a Unit of Development

A Watershed is a Hydrological unit which is most suited for managing land and water holistically. However, there is no harm in applying this integrated approach even to a single village which is only a part of a larger watershed. Since a village is an independent revenue unit and most revenue records are maintained village-wise, most of the official rural development projects are still undertaken on the basis of a village. For the management of common natural resources, the use of a hydrological unit, i.e the watershed offers a few strategic advantages as discussed below.

- The primary source of all water in an area is rainfall. A watershed being an independent drainage unit, the water available in one watershed differs from that in another. Although, this total available water occurring as surface water, groundwater and soil moisture varies in time (season) and space (location), each watershed therefore has its own *quota* of water. Management of water resources is therefore better achieved when the water resource is evaluated and utilized on watershed basis.
- Most well-defined watersheds have three distinct physiographic units, namely the upper reaches, intermediate reaches and lower reaches. The conservation measures undertaken in the upper reaches not only have direct effects in the upper reaches but also in most cases have sufficient indirect effects to the downstream areas. Preparation of a comprehensive development plan, taking into account all these effects, becomes possible when the resource development plan is considered comprehensively on watershed basis.
- Demands for available water from various water users in different upstream and downstream villages are not only on the rise but are also a potential source of inter-village and intra-community conflicts. Once the available quantity of water within a watershed is properly assessed, it is possible to make provisions for water allocation to each group based on availability and acceptable trade-offs. This provides an opportunity to bring about equity in water use by suitably developing the watershed and promoting efficient

water conservation and utilization practices.

Whatever are the reasons, there is hardly any dispute in accepting a watershed as the unit of development specially for the management of the land, water and vegetative resources. This shift from village to watershed as the unit of development sometimes creates a few practical difficulties. A common problem encountered is in reconciling village-level revenue data with the corresponding watershed-level data, particularly when a part of the village lies outside the identified watershed boundary. Sometimes, such areas are excluded from the project area and therefore, are deprived of the project benefits. But when these areas are part of the upper reaches of the adjacent watershed area, inclusion of the village under the WSD project is still desirable.

It is therefore of definite advantage if the entire project area is segregated into micro-watersheds. Resource management plans can then be undertaken for the entire village keeping in mind which part of the village belongs to which micro-watershed.

#### **1.4.4 Watershed Atlas**

A National Watershed Atlas has been prepared by the department of All India Soil and Land Use Survey for identifying each sub-watershed in the country with a unique code number (AISLUS, 1990). The entire country has been divided into 8 water resource zones containing about 3248 sub-watersheds ranging from 2000 to 4000 ha in size on a drainage map of 1:1 million scale. In order to allocate each sub-watershed with a unique identification code, a four-stage system of classification has been followed. The entire river basin has first been divided into its major catchments labelling them arbitrarily, beginning from downstream upwards as a, b, c,... Each catchment has then been divided into the constituting watersheds allocating numbers 1, 2, 3 ....9. These Watersheds are further divided into a number of sub-watersheds identifying them once again serially as a, b, c... .

Each sub-watershed can therefore, be identified by an unique identification code formed by combination of these numbers and are usually preceded by the first letter of the name of the river basin. Thus for example, a sub-watershed having a code of Tb2d would uniquely identify that particular sub-watershed "d" which is a

part of the larger Watershed numbering "2" of a still larger catchment area "b" of Tilaya river basin (T). The state code may also be prefixed so as to make the nomenclature complete.

#### **1.4.5 Demarcation of Watershed Boundary**

While a simple or a first order watershed comprises of a single stream, a multi-order watershed comprises several such single order watersheds. The entire drainage area of a major river system is referred commonly as a river basin which in fact is comprised of a large number of watersheds.

##### *Use of Maps*

Demarcation of watershed boundary in a map (topo-sheet or satellite imagery) is done by visually inspecting the drainage lines of the area. Based on visual inspections, a rough boundary is first drawn along the drainage divides around a set of drainage lines that converge to a common outlet. The rough boundaries of the watersheds are then finalized confining them to the desired size. For detail planning, the watershed maps so obtained are normally enlarged and superimposed over a village revenue map known as the cadastral map (1 cm = 40 m) to serve as an effective working map for the project.

##### *Field Demarcation of Watershed*

The approximate boundary of a small watershed can also be demarcated in the field by visual inspections involving two surveyors. One of the surveyors walks along the main stream in the upstream direction (opposite to the flow direction) until the highest point or the ridge line is reached. The second surveyor stationed at the outlet (lower reaches) of the stream, by looking at the sky line, guides the first surveyor, to move a bit forward or backward to make him stand exactly at the highest point. A landmark pillar or boulder is placed at this highest point. The process is repeated for all the streams (tributaries) to demarcate an approximate boundary in the field. A further fine-tuning of the boundary of the main watershed and its constituent micro-watersheds is possible by making enquiries with local farmers about the general flow directions of surface run-off observed after a heavy Rainfall.

### 1.4.6 Categorization of Watersheds

Watersheds may be classed in a number of groups, depending upon the mode of classification used for the purpose. Common modes of categorization are outlined below.

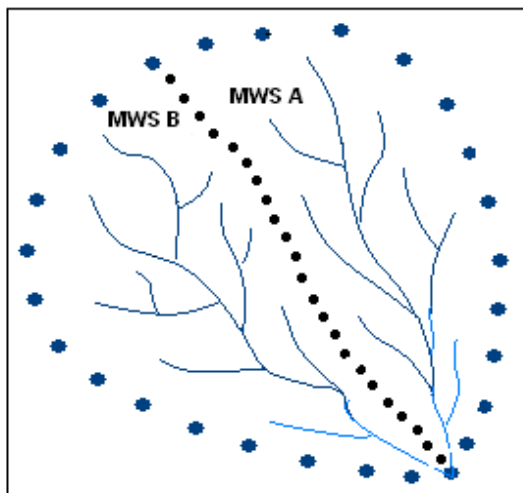

Figure 1.1 Watershed boundary as delineated in a map

#### ***Based on Size***

A watershed is termed as large, mini or micro depending upon its size. This criterion has been evolved keeping in mind the size which can be managed for implementation by various project implementing agencies within a reasonable period. From the management point of view, a micro-watershed is one which has a single drainage (first order stream) with its subsidiary branches extending to an area not more than 500 ha. Mini-watersheds are those which comprise a number of drainage systems spreading to an extent of more than 500 ha but confined to 2000 ha. A large watershed is one which has an area of more than 2000 ha.

#### ***Based on Drainage***

The drainage characteristics of a watershed can broadly be related to its drainage pattern, stream density and drainage density. Drainage pattern is studied by visual inspection of a drainage map. Stream density of a watershed is the number of streams per unit area (sq.km). High stream density is an indication of highly undulating terrain. Drainage density is the total length of all the stream channels both perennial and intermittent per unit area (sq.km) of the basin. Drainage density indicates the drainage efficiency of the basin. A higher value indicates a well-developed network and high run-off causing intense flood, while a lower value indicates relatively moderate to low run-off and higher permeability of the terrain.

### ***Based on Shape***

A watershed can also be described as either fan shaped (near circular) or fern shaped (elongated). Hydrology point of view, the shape of a watershed is important because it controls the time taken for the run-off to concentrate at the outlet. The time taken for the run-off water to travel from the furthest point of the watershed to the outlet is known as time of concentration (tc). A fan shaped or near circular watershed provides greater flood intensity at the outlet as all the tributaries are of nearly the same length and their times of concentration are nearly the same. But in an elongated watershed the time of concentration for each tributary is different and the discharge at the outlet is distributed over a longer period. Computation of *time of concentration* (tc) at a given location of a stream is useful for designing water retention structure at that site.

### ***Based on Other Criteria***

From administrative and management points of view, watersheds may also be categorized into several other types. Thus for example, watersheds may be termed as *hill- watershed* or *flat - watershed*; *humid- watershed* or *arid- watershed*; *red soil watershed* or *black soil watershed* etc. using topography, climate and soil type as the main identifying criteria respectively. From management point of view, it is also useful to distinguish watersheds into these three types as per their land use pattern. The hill watersheds are located at higher elevations of river catchments consisting predominantly of forest where soil conservation and afforestation are the main components of watershed treatment. Management of these watershed are left largely to the forest department. Watersheds are also identified from the degree



of soil erosion point of view using an indicator called Soil Yield Index (SYI) developed by AISLUS.

## **1.5 SCOPE OF INTEGRATION**

Thus, the activities for soil conservation, moisture conservation, water harvesting, groundwater recharge, conservation of water in irrigation application etc. lead to an enhanced availability of water. Expansion of Rabi crops and integrated pest management are being increasingly common in well treated watersheds. Use of portable pipes and sprinklers are ideal for increasing both the transmission and application efficiency. Use of drip irrigation in horticulture and row crops is extremely effective in saving water. Improved agronomical practices (mulching, zero tillage, use of farm yard manure etc.) are important soil moisture conservation measures.

Recent trials have shown that rice grown following the SRI technique consumes much less water while producing higher yield thereby opening up new opportunities for growing rice in rain-fed areas. Many ancillary activities e.g rope making, basket making, small scale fishery, food processing through SHGs etc. can be included. Likewise, beginning with the development of additional fodder, a project can keep promoting improved veterinary care, establishment of a milk marketing union and even artificial insemination centres as per the need and capacity of the local communities.

### **1.5.1 Physical components**

An attempt has been made to list out the major physical activities that are traditionally undertaken in most integrated watershed development projects. Although, such activities have been grouped under appropriate headings, many of these activities are inter-related to each other and hence quite often are implemented together. The common physical components that are integrated within a watershed are.

#### **A. *Soil and Water Conservation***

Land levelling

Field bunds, contour bunds and graded bunds  
Field ditches and contour ditches  
Gully plugs : earthen, stone, vegetative  
Excess water disposal structures  
Check dams (overflow weirs)  
Earthen bunds with masonry spillway  
Percolation tanks, field ponds  
Underground bunds/dykes  
Construction of wells and lifting arrangements  
Improvement in irrigation application techniques

## **B. *Plantation***

Collection and storage of seeds  
Nursery raising  
Plantation of seedlings and their protection  
Developments of grasslands and silvi-pasture  
Agro-forestry and bund plantation  
Farm forestry and industrial plantation  
Horticulture and vegetable cultivation  
Shelter bed plantations  
Propagation of medicinal plants

## **C. *Agronomical Practices***

Improvement of tillage practices  
Promotion of double crops  
Practices of inter-cropping/mixed cropping  
with new/improved varieties  
Organic farming/compost making/vermiculture  
Decrease in the use of inorganic fertilizers and pesticides  
Management of soil moisture and irrigation water  
Crop rotation on trial basis/ crop diversity

## **D. *Livestock***

Production, storage and management of fodder  
Improvement in livestock health and quality  
Rearing of small animals (goat, duck, poultry) for subsidiary income  
Fishery  
Developing market linkages for produces

### **E. *Renewable Energy***

Development of biogas  
Energy-efficient and smokeless stoves  
Energy plantation  
Gasifier and charcoal making  
Solar cooker, dryer, heater, water distillation plant, lighting etc.  
Micro-hydel and other water-driven appliances

### **F. *Institutional developments***

The project implementing agency is required to undertake several activities related to institutional development throughout the project period considered useful not only for mobilizing community participation but also to sustain the development results created through this process. Although the requirements may vary from project to project, but the basic steps are enumerated as below.

- Establishment of rapport through entry programme(s).
- Creation of awareness about the project objectives.
- Preparation of village level implementation plan in consultation with the relevant communities.
- Formation of user groups and project management committees.
- Development of capacities within the user groups and management committees.
- Implementation of project components through user groups and project management Committees, as far as possible.
- Mobilization of community contribution both in cash and kind.
- Conflict resolution and follow up.

Conservation of available resources will be possible only when resource users become aware of the limitations and adopt technologies and practices that allow more efficient utilization. It is therefore obvious that in addition to application of technically sound physical measures, watershed management will also require creation of various groups to enable them to manage their natural resources keeping in view the need of other communities. Even, judicious management of privately held resources like land, water and livestock is not possible only through individual efforts. Management of natural resources is a task of the community, for the community and by the community. The type of groups usually formed in a watershed development project are:

- User Groups
- Watershed Committee
- Self Help Groups
- Community Centre for meetings
- Augmentation of income through agro-processing/marketing groups

Although the physical activities to be implemented in all watershed management projects appear to be more or less the same, but due to the varying nature of each watershed, there will be sufficient variation in the process of actual implementation rendering each project a unique experience.

## **1.6 LONG TERM BENEFITS**

The direct benefits expected to accrue from successful implementation of an Integrated watershed development project are many. The extent of benefits will, however depend upon the size of the watershed, effectiveness of the implemented measures and efficiency in the utilization of the created benefits. Some of the commonly benefits are:

- Degradation of the natural resource base is retarded, neutralized and reversed. Reclamation measures adopted in degraded lands, initiate the process of improvement of the land giving rise to increased production of biomass. This in turn improves soil fertility and the cycle of improvement continues.

- Improvement in land capability and soil fertility brings about improved agricultural practices giving rise to increased crop yields and option for a wider crop variety.
- In addition to providing water for direct irrigation, water storage structures also contribute to enhancement of soil moisture regime in the vicinity useful for crops and vegetations. Under certain conditions, stored water also contributes to groundwater recharge.
- Degraded community lands successfully planted with useful trees and grasses, become useful sources for the much needed fuel, fodder, food fibre, fertilizer and employment for village communities.
- Reduced biotic interference in forest lands help the forest regenerate to their normal health which in turn aids in moderating surface run off leading to water flow in the streams for a longer period.
- Improvement in agricultural productivity triggers growth in agro – based and other income generating activities.
- Availability of increased drinking water, fodder, fuel, timber etc. reduces drudgery and brings about an improvement in quality of life specially for the women from the poor communities.

It should be borne in mind that the most serious challenge while of integrated watershed management is to achieve higher production from the existing natural resource bases without over-exploitation. The guiding principles of management are based on conservation, development and efficient utilization. Sustainable management of natural resources would therefore mean increase in productivity without further degrading the natural resource base. For example, increase in milk production does not mean procurement of more cattle but improvement in the existing breed. Similarly increased groundwater need not mean deepening of the existing wells but rather raising the water table through artificial groundwater

recharge. Similarly, increase in irrigation facility would mean improving conveyance and application efficiencies of the available irrigation water.

## **1.7 NEED FOR MULTI-DISCIPLINARY KNOWLEDGE BASE**

Natural resource management requires scientific understanding on the occurrence and distribution of these resources as well as their responses to conservation measures. In order to plan and apply effective watershed treatment measures, the implementing agency is therefore required to have access to wide variety of subject matter experts. These are inter alia, civil engineers (for survey, design, cost estimation, construction), hydrologist for surface water, ground water development), agronomist (soil and moisture conservation, agriculture), experts on animal husbandry, horticulture, plantation and a host of other community mobilization experts. Understanding is also required on how the benefits accrued are to be shared equitably by the user communities and how they would manage the created assets in the future.

However, since a single project implementing agency can not possibly have all these specialists within its project team, such technical expertise could be accessed from external sources. But, it would be of advantage, if the members of the project team possess some basic knowledge on various inter-disciplinary subjects. It is evident that each watershed management project has two basic premises. One is the technical aspects related to the implementation of physical components and the other is the socio-managerial aspects dealing with mobilizing and sustaining community participation.

Keeping these requirements of project planning and implementing practitioners in mind, this book has been presented in two parts. The first part deals with the physical and engineering aspects of watershed management including a chapter each on hydrology, geohydrology, soil and land capability, soil conservation and water harvesting, water requirement of crops, afforestation and climate variability. The part two has devoted exclusively on various aspects of project formulation, appraisal and implementation including monitoring and evaluation.

## **2.0**     *Watershed Hydrology*

---

### **2.1**    **HYDROLOGIC CYCLE**

Hydrology is the science which deals with the occurrence, distribution and movement of water within the earth and its atmosphere. Hydrologic cycle is the dynamic water transfer system of nature wherein the water is continuously moving and changing from one form to another, while its sum total remaining the same. Although by definition, hydrology encompasses groundwater studies as well but in its application, GW is studied by a different set of experts commonly known as **geohydrologst**, hydrogeologist

After reaching the earth surface, rainfall (or snow) continues to move and change its form. The part that enters the soil is infiltration, the part which flows along the surface is run-off, the part which goes back to the atmosphere as water vapour is evaporation and the part that is transpired by the plants back to the atmosphere is transpiration. Furthermore, the part which is intercepted by leaves and stems of the existing vegetative cover is interception, the part which is collected on the surface is surface storage, the part which is retained in the soil is soil moisture and the part which is percolated below the soil zone to join the saturated zone is groundwater. Thus, the static water balance equation in its simple form may be written as:

Precipitation = Run off + Evapo-transpiration + Change in Storage

### **2.2**    **PRECIPITATION**

Deposition of atmospheric water to the surface of the earth in the form of rain, snow, hail, fog, mist, dew etc. is precipitation. Maximum precipitation, however, is received as rain and in some areas as snow.

#### **2.2.1**   **Rainfall in India**

Other than temperature, rainfall is the single most important factor which decides our life style and agriculture of a region. Rainfall in India is seasonal. Annual

rainfall varies widely which ranges from less than 100 mm in some western parts of Rajasthan to more than 4000 mm in some north eastern parts. The average annual rainfall in India is to the order of 1175 mm which takes place on an average of 120 rainy days.

Excepting Kashmir and Southern peninsula, about 75 to 80% of the annual rainfall takes place in the country during the South-West monsoon between June to September. The North-East or the return monsoon is a typical feature in parts of north east and south India which gives moderate rainfall during the months of October to December. The remaining of the rainfall occurs as winter rains, thunderstorms and other atmospheric disturbances. The lines joining the locations of equal annual rainfall in a map is known as isohyets.

Based on average annual rainfall, the country has been divided into three major regions namely:

Arid Region:	Rainfall less than 500 mm
Semi-arid Region:	Rainfall between 500 – 1000 mm
Humid region:	Rainfall more than 1000 mm

### **2.2.2 Variations in Rainfall**

Rainfall data in India is collected for each revenue Block and are processed centrally at the Indian Meteorological Department (IMD), Pune. Average rainfall, humidity, temperature, wind speed, sunshine hour of some selected observatories are available in a published volume namely Climatological Tables of Observatories in India. Recent rainfall data are readily available from the respective block offices. Although rainfall in India follows a seasonal pattern but it still has wide deviation to make it unpredictable within a season. Variation in rainfall is relatively high in the arid regions compared to that of humid regions.

One method of measuring the variation in annual rainfall statistically, is to compute the standard deviation ( $\sigma$ ) and coefficient of variation of rainfall (Cv) which are given by:

$$\sigma = \sqrt{\sum (X_i - \bar{X})^2 / N}$$



$$C_v = (\sigma / X^1) * 100$$

Where,

$X_i$  = Annual rainfall for each year  
 $N$  = Number of years  
 $X^1$  = Mean =  $\Sigma(X_i/N)$

Annual rainfall data for minimum 10 years or more are collected to compute the  $C_v$ . Higher the value of  $C_v$ , greater is the tendency in departure of rainfall from the normal and vice versa. Values of  $C_v$  in India vary from 15% to 70%, the mean being 30%. While western Rajasthan and Tamilnadu have high variation in rainfall with  $C_v$  to the order of 50% and more, the same for eastern India and western Ghats are to the order of 20%.

## **2.3 DROUGHT**

Drought denotes scarcity of water in a region for a short period of time. In normal sense drought is caused due to shortage of rainfall. Since drought is basically a non-event, it does not have a distinct time of onset. Effects of drought are normally felt only after a few months. In India, drought is said to have taken place when annual rainfall is less than 75% of the normal. The situation is described as severe drought when annual rainfall is less than 50% of the normal. The severity of drought is assessed by the degree of moisture deficiency (Intensity), duration of dry spell and the extent of affected area.

However, in a highly degraded area with excessive run-off or in an area with sudden increase in water demands, a drought like situation can take place even during a normal rainfall year. Conversely, effects of drought may not be as severe in an area, even in a low rainfall year, if it has created facilities for sufficient storage of water. Such paradoxes have necessitated the need to distinguish droughts of different nature and origin such as:

### **2.3.1 Meteorological Drought**

This is a condition when the annual rainfall is less than the normal over an area for

a prolonged period. It is based on rainfall and is associated with a month, season or a year.

### **2.3.2 Hydrological Drought**

This occurs when a prolonged meteorological drought results in drying of the available water sources e.g streams, tanks, reservoirs, wells etc. It is related to the shortage of available water in the storage facilities.

### **2.3.3 Agricultural Drought**

This is a condition resulting in the shortage of supply of water to meet the demands for crop maturity. It is the result of moisture stress in soil during crop growth i.e imbalance between available soil moisture and evapo-transpiration.

## **2.4 RAINFALL PARAMETERS**

Rainfall of an area is the total volume of water that precipitates within that area. It is not practically feasible to measure the entire volume of rain water that falls in an area. Rainfall is, therefore, measured at a given location using a raingauge expressed in depth of water. Thus, a rainfall of 36 mm recorded by a particular rain-gauge would mean that if the entire rainfall was allowed to stand evenly over the entire area at which the rain occurred, the depth of the standing water would have been 36 mm. In the absence of a number of raingauges, data from one raingauge is considered valid for the entire area of rainfall.

Rainfall is a random hydrologic phenomenon. To understand its dynamics, the important variables studied are its distribution, duration and intensity.

### **2.4.1 Distribution**

Distribution of a rainfall simply means the extent of the area within which the rainfall occurred. For example, a particular rainfall may take place either over the entire river basin or only in a part of the same. While the former will be described as evenly distributed rainfall over the river basin, the latter will be referred to as unevenly distributed or localised rainfall.

## **2.4.2 Duration**

Duration of rainfall is the time period over which the rainfall has occurred. Duration is measured in minute or in hour.

## **2.4.3 Intensity**

Intensity is the rate at which the rainfall takes place i.e. the depth of rainfall per unit time. It is normally expressed in mm/hr. For example, if the rainfall in a station is measured as 36 mm, this rainfall could have occurred in any particular time period of say 1 hr, 10 hr, 24 hr. Although, the depth of rainfall is 36 mm, but the intensity, considering the above three time periods (durations) becomes different which are  $36/1 = 36$  mm/hr,  $36/10 = 3.6$  mm/hr or  $36/24 = 1.5$  mm/hr respectively. Rainfall intensity upto 2.5 mm/hr is known as light rain, between 2.5-7.5 mm/hr as moderate rain and above 7.5 mm/hr as heavy rain. An Intensity of 25 mm/hr in an arid region is considered exceptionally high which may take place say once in 10 years.

## **2.5 MEASUREMENT OF RAINFALL**

Rainfall is measured by raingauge which are of two types; the recording type and the non-recording type.

### **2.5.1 Non-Recording Raingauge**

Non-recording type of raingauge used extensively in India is the Symon's gauge. A standard Symon's raingauge (Fig.2.1) consists of a circular funnel of 12.7 cm (5 inches) diameter placed over a glass bottle, both encased in a cylindrical metallic casing. Rain water falling into the funnel is collected in the glass bottle. Later this water is poured into a special cylindrical measuring glass graduated in mm to obtain the depth of rainfall. When full, the measuring glass can measure 20 mm of rainfall. In 1969, fibre glass reinforced polyester (FRP) raingauge was introduced in India. These have inlet diameters of 11.3 cm or 16 cm i.e 100 sq.cm or 200 sq.cm inlet areas respectively.

A raingauge is placed in an open space away from tree etc with adequate protection

against physical damages. As per standard practices, the raingauge is fixed perfectly vertical to a masonry foundation with the level of funnel rim 30.0 cm above the ground surface.

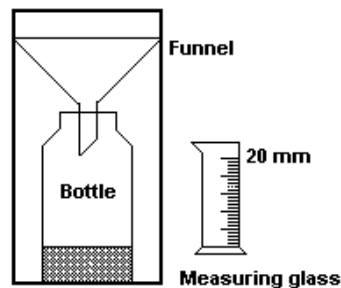

Fig. 2.1 Symon type non-recording raingauge

The rainfall, for the sake of uniformity is measured every morning at 8:30 hours which gives the total depth of rainfall in the last 24 hours. During heavy rains, measurement should be taken a few times a day, lest the bottle gets filled up and overflows. The data collected are maintained in a tabular form. Non-recording type of raingauge however gives only the total depth of accumulated rainfall. It cannot record the duration and hence can not give the intensity of rainfall.

### 2.5.2 Recording Type Raingauge

Tipping bucket raingauge (Fig.2.2) is the recording type raingauge commonly used in India. It consists of a funnel of 16 cm diameter with a pair of tipping buckets (collectors) pivoted just below the funnel. When one of the buckets receives certain amount of rain water (0.1 mm or 0.2 mm), it tips and empties the water content into the bottle below while the other collector takes its position and the process is repeated. The tipping of the collector bucket actuates an electric pulse which causes a pen to move up by one unit of vertical division on the graph paper placed over a drum which is rotated by a clock mechanism. The water stored in the bottle can also be measured manually by using properly calibrated measuring glass.

### 2.5.3 Analysis of rainfall Chart

Charts from all automatic type of raingauges are the plots of the cumulative rainfall against time. In a chart, rainfall is recorded in the form of series of

ascending lines with varying slopes. The horizontal axis denotes time and the vertical axis denotes the amount (depth) of rainfall. While the vertical scale remains fixed as per the gauge type (normally 1 cm=1 mm), the horizontal scale is determined by the speed at which the clock is set.

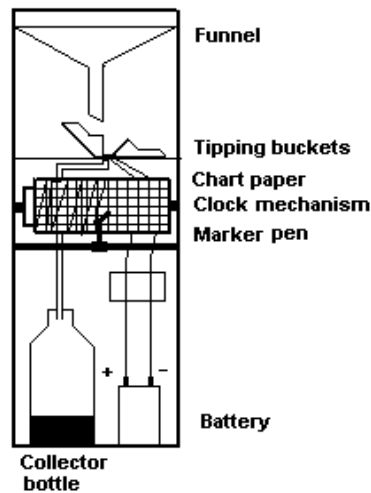

Fig. 2.2 A combination of both recording and non-recording type of raingauge

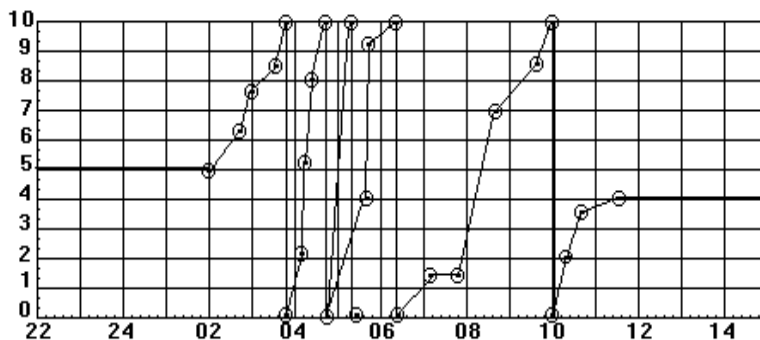

Fig. 2.3 A typical rainfall chart from a recording type (tipping bucket) of raingauge

However, since the intensity of rainfall changes considerably throughout its duration, total duration of a rainfall can be divided into a number of smaller durations during which the intensity remained more or less the same. A close look at any rainfall chart will therefore show that the recorded lines can be broken into smaller segments of equal slope. Each of these segment represents rainfall of a

particular intensity and their corresponding time intervals are their durations.

For the sake of easy interpretation and analysis, it is advisable to convert rainfall chart into a tabular form. Table 2.1 has been prepared from the rainfall chart as shown in Fig.2.3. Here, the entire vertical scale is equal to 10 mm of rainfall and each horizontal division is 1 hr (i.e line speed 10 mm/hr). The rainfall started at 02.00 hr. and ended at 11.30 hr.i.e the total duration is 9 hours and 30 minutes. During this period total depth of rainfall is 49 mm.

It is found from the Table 2.1 that the total rainfall is 49 mm which took place over a period of 9 hr 30 min. (570 min.). There is also a small period between 7.12 to 7.48 hr (36 min.) when no rainfall took place. Average intensity of this rainfall is given by  $49/(570 - 36) = 0.092$  mm/min or 5.5 mm/hr. The highest intensity of rainfall is however 31 mm/hr which took place between 4.06 to 4.12 hr. In fact the actual depth of rainfall during this 6 minutes is 3.1 mm i.e  $3.1/6 = 0.516$  mm/min which when multiplied by 60 gives the intensity as 31 mm/hr.

Time	Increment of time, min	Cumulative time, min	Rainfall mm	Cumulative Rainfall, mm	Intensity Mm/hr
2.00	-	-	-	-	-
2.54	54	54	1.2	1.2	1.33
3.0	6	60	1.3	2.5	13.0
3.24	24	84	1.0	3.5	2.5
3.48	24	108	1.5	5.0	3.75
4.06	18	126	2.2	7.2	7.33
4.12	6	132	3.1	10.3	31.0
4.24	12	144	2.7	13	13.5
4.42	18	162	2.0	15	6.6
5.12	30	192	10.0	25	20.0
5.54	42	234	4.0	29	5.71
6.06	12	246	5.6	34.6	28.0
6.30	24	270	0.4	35.0	1.0
7.12	42	312	1.5	36.5	2.14
7.48	36	348	-	36.5	-

8.42	54	402	5.5	42.0	6.11
9.42	60	462	1.7	43.7	1.7
10.0	18	480	1.3	45.0	4.33
10.18	18	498	2.0	47.0	6.66
10.54	36	534	1.5	48.5	2.5
11.30	36	570	0.5	49.0	0.83

**Table 2.1 Analysis of rainfall chart for obtaining intensity of rainfall from different durations.**

## **2.6 RUN-OFF**

Surface water flow that originates due to rainfall is run-off. After the rainfall satisfies the immediate needs of the evaporation, infiltration, interception by foliage and storage due to natural surface depressions, the excess water starts flowing as run off.. Since run-off is the volume of water moving per unit time at any location of the stream, it is normally measured as discharge in cubic metre per sec ( $m^3/sec$ ). Overland flow which is difficult to measure can be measured only at a suitable outfall by filling in a container of known volume and noting the time taken to fill the same.

### **2.6.1 Factors Affecting Run-Off**

Generation of run-off from a watershed is controlled by factors associated with Precipitation Characteristics, Watershed Characteristics, Geological Characteristics and Meteorological characteristics.

#### ***A. Precipitation characteristics***

Precipitation characteristics are :

- Intensity of rainfall
- Duration of rainfall
- Distribution of rainfall

For any particular watershed, larger the duration, intensity and distribution of rainfall, greater is the volume of run off. A rainfall of smaller duration will not

produce much run-off since the initial infiltration rate is relatively high. As the duration of the rainfall increases, volume of run-off increases. Similarly, for a rainfall of given duration and distribution, higher the intensity of rainfall, greater will be the rate of run off. For example, 30 mm rainfall occurring throughout the watershed within an hour will generate relatively higher run-off than if this 30 mm rainfall had taken place over a period of say 5 hours. Rate of infiltration is much less during an intense rainfall and hence generates more run-off.

It is obvious that for a particular rainfall, maximum volume of run-off will be generated when the rainfall is evenly distributed over the entire watershed area. However, at times a very intense rainfall occurring in a smaller part of a relatively large watershed may result in greater run off than a low intensity rainfall spread over the entire watershed.

### ***B. Watershed characteristics***

Watershed characteristics are :

- Size and shape
- Topography (slope groups)
- Land use

#### *Size and shape*

It is obvious that larger the size of a watershed, higher will be the yield of run- off. However if the rainfall occurs only in a small part of the watershed, the size of the watershed would effectively become only that part of the watershed in which rainfall took place.

Shape of a watershed does not have any effect on the total volume of the run-off but the shape would influence the time of concentration and hence the peak discharge. A circular watershed will generate higher peak discharge than an elongated watershed of the same size.

#### *Topography*



Slope of the land surface is a major factor in controlling the velocity of run-off. Higher the slope, higher will be the velocity of the run-off. Experiments have shown that velocity of water is proportional to the square root of the drop (head). In other words, if slope of a land is doubled, the velocity of run-off will increase by four times. Run-off with higher velocity will attain a higher peak discharge. In lands with high slope, the retention period being less, the infiltration is reduced and the run-off is increased to the extent the infiltration is reduced.

In a rolling topography, marked by alternate mounds and depressions, run-off will be reduced because water will tend to accumulate in the depressions. Moreover water has to flow a long torturous path in order to skirt the mounds. This would increase the retention period giving rise to sufficient evaporation and infiltration thus reducing run-off. However, if the watershed is full of ravines, the run-off yield will be higher than a normal watershed.

### *Land use*

All the existing features on the ground surface like vegetative covers including crops, forest and other structures created artificially like embankments, check dams, terraces, bunds, roads, buildings, ponds and the like constitute the land use pattern. Presence or absence of these types of structures can reduce or increase the run-off respectively. A large amount of rainfall is intercepted by the branches and leaves of the plants which in course of time is either evaporate back to atmosphere or trickle down to sub-surface resulting in increased infiltration. Thick litters in the forest floor also hold large quantity of rain water, facilitating both infiltration and delayed run-off.

### *C. Geological characteristics*

Geological characteristics are manifested by :

- Soil type and
- Physiographic controls

Geology influences the topography as well as the soil type of a watershed. Soil affects run-off directly due to its inherent infiltration capacity. More porous and

permeable the soil is, the more will be the infiltration resulting in less run-off. Soil condition is also indirectly responsible for vegetative growth which in turn reduces run-off.

#### ***D. Meteorological characteristics***

The Meteorological characteristics include:

- Temperature
- Humidity
- Wind speed
- Sunshine hour

Meteorological factors like temperature, humidity and wind speed have indirect and thus relatively minor effects on run-off specially during and immediately after a rainfall. Strong wind blowing along the direction of the surface flow during a high intensity storm however can considerably increase the velocity of run-off causing extensive soil erosion. Temperature and humidity affect the rate of evaporation. As the rate of evaporation is increased, the amount of run-off is reduced. Wind speed also increases the evaporation but beyond a certain level increase in wind velocity does not increase evaporation proportionately. However, it is the long term or the seasonal effects of meteorological parameters on surface water flow and storage deserve special attention.

### **2.7 ESTIMATION OF RUN-OFF**

While designing a storage structure, it is necessary to estimate how much water will be available at site during both the lowest and highest rainfall years respectively. Knowledge of minimum flow is necessary to ensure that the structure stores at least the minimum required quantity of water. Knowledge of maximum discharge or the peak discharge is also essential to design the structure such a way that it remains safe. The term Catchment area is used in the context of construction of a structure at a site to indicate the area from which it will receive its water. At the outlet of a watershed both the catchment area and the watershed area are the same. However, at some other location within the watershed, catchment area will be smaller in size than the watershed area.

Several methods have been developed to estimate peak discharge at the outlet of a watershed which is useful for designing water retention structures (see Chapter 6). A simple empirical method is discussed below for estimating run-off as percentage of Precipitation (rainfall) for a given catchment.

### 2.7.1 Estimation of Run-off as percentage of Rainfall

It is applicable for a particular rainfall and is given by:

$$R = K_1 \times K_2 \times P = KP$$

Type	Description of catchment	Coeff. $K_1$
A	Flat, cultivated, black cotton soil	0.10
B	Flat, partly cultivated, various soils	0.15
C	Average catchment	0.20
D	Hills and plains with little cultivation	0.35
E	Very hilly and steep without any cultivation	0.45

**Table 2.2a Barlow's coefficients ( $K_1$ ) for the type of catchment for average rainfall**

Nature of rainfall	Type of catchments				
	A	B	C	D	E
Light rain	0.7	0.8	0.8	0.8	0.8
Average rain	1.0	1.0	1.0	1.0	1.0
Continuous downpour	1.5	1.5	1.6	1.7	1.8

**Table 2.2b Barlow's coefficient ( $K_2$ ) for the type of rainfall**

where,

R = Run-off, cm

P = Precipitation, cm

$K_1$  = Run off coefficient for the type of catchment

$K_2$  = Run off coefficient for the type of rainfall

Values of  $K_1$  and  $K_2$  are obtained from the following tables.

Some typical examples for computing Barlow's coefficient ( $K$ ) are presented below:

Average catchment and average rainfall:  $K = K_1 K_2 = 0.2 \times 1.0 = 0.20$

Hilly catchment and continuous downpour:  $K = K_1 K_2 = 0.45 \times 1.8 = 0.81$

Flat catchment and continuous downpour:  $K = K_1 K_2 = 0.1 \times 1.5 = 0.15$

### ***Problem 2.1***

Estimate run-off yield due to 20.0 cm rainfall that took place in 2 hours over a partly hilly and partly plain catchment of 2000 ha area.

### ***Solution 2.1***

10 cm Precipitation ( $P$ ) may be considered as continuous downpour. Thus, from Barlow's table

6.1a and 6.1b, we have

For partly hilly and partly plain catchment (D):  $K_1 = 0.35$

For continuous downpour and type D catchment:  $K_2 = 1.7$

Rainfall = 10 cm/2 hr = 5 cm/hr

Total Volume of Run-off =  $K_1 \times K_2 \times P \times A = 0.35 \times 1.7 \times 10 \text{ cm} \times 2000 \text{ ha} = 11900 \text{ ha-cm}$

= 119 ha-m

Total volume of rainfall that took place over the catchment area =  $0.1 \text{ m} \times 2000 = 200 \text{ ha-m}$

Percentage of run off over rainfall =  $(119/200) \times 100 = 59.5 \%$

Rate of Run-off =  $119/2 \text{ hr} = 59.5 \text{ ha-cm/hr} = (59.5 \times 10000) / 100 \text{ m}^3/\text{hr} = 5950 \text{ m}^3/\text{hr}$

### **2.7.2 Estimation of High Flood discharge**

The maximum rate at which water flows down a catchment is known as Maximum rate of run off or High flood discharge or Intensity of maximum flood or Peak rate of run-off. Sufficient estimation of High flood discharge is essential for safe design of water retention structure (Bunds, Weirs). For small catchments for which systematic data collection is not practicable, most popular approach is the application of the Rational formula which is given by

$$Q = (CIA) / 360$$

Where,

Q = High flood discharge, m<sup>3</sup>/sec

C = Run-off Coefficient

A = Size of catchment area, ha

I = Intensity of rainfall in mm/hr for a period equal to the time of concentration (tc) of the catchment area for a design frequency interval (recurrence interval) T.

The following values of C are assumed for different typed of soils.

Sandy Soil : 0.29

Sandy Loam : 0.40

Clayey Soil : 0.50

Time of Concentration (tc) is the period taken for the run-off to travel from the furthest point of the catchment to the point of measurement and is given by

$$tc = (0.87 \times L/H)^{0.385}$$

Where,

L = Distance from furthest point to proposed site

H = Fall of Travel (Vertical distance) from furthest point to the proposed site.

Recurrence interval T is the number of years in which an exceptional high flood discharge is likely to occur once in T years. This is considered in order to safeguard the structure against an incidence of exceptional high flood discharge

some times in the future. It is recommended that the Intensity of rainfall (mm/hr) be taken from 25 years rainfall data.

### ***Problem 2.2***

Compute the Time of concentration ( $t_c$ ) of a weir construction site whose distance from the ridge line is 500 m and fall in level is 8 m. What would be the Peak rate of run-off at the site if highest rainfall of the area as obtained from 25 years rainfall frequency chart is 80 mm/hr, run-off coefficient  $C$  is assumed as 0.35 and the size of the catchment is 50 ha.

### ***Solution 2.2***

Time of Concentration( $t_c$ ) is obtained as

$$t_c = (0.87 \times 0.5 / 8.0)^{0.385} = 0.20 \text{ hr} = 12 \text{ min.}$$

Highest rainfall from 25 years frequency chart is found to be 80 mm/hr. Using the Rainfall – Intensity – Duration curve developed for this purpose, rainfall intensity for 12 min. is found to be 200 mm/hr.

$$\text{The Peak Rate of Run-off } Q = CIA / 360 = (0.35 \times 200 \times 50) / 360 = 9.72 \text{ m}^3/\text{sec}$$

The structure to be constructed at this site should be designed to withstand the force of maximum discharge of say  $10 \text{ m}^3/\text{sec}$ .

## **2.8 MEASUREMENT OF STREAM DISCHARGE**

In field, the total amount of run-off that leaves a watershed, is measured at its outlet. Mean discharge multiplied by the duration of flow gives the volume of total run-off from the watershed. Since, the discharge at the outlet of a watershed varies with time, it is necessary to collect discharge data at close intervals throughout the period of the flow. Discharge data from any flowing stream of smaller size is obtained by the Area-Velocity method. Alternately, for large streams, the continuous measurement of discharge is made by using a continuous water level recorder installed in a stilling well constructed at the bank of the stream

known as stream gauging station. Discharge is computed simply from the water level variations as the cross-sectional area of the stream at the site is already known from survey carried out earlier. .

### **2.8.1 Area-Velocity method**

This is by far the most popular method of measuring discharge at any given location and any time from a small stream/river. In this method, both the cross-sectional area and the velocity of the stream are measured at site. Discharge (Q) is then obtained from the following formula.

$$Q = V_m \times A$$

Where,

Q = Discharge, m<sup>3</sup>/sec

V<sub>m</sub> = Mean velocity of flow, m/sec

A = Cross-sectional area, m<sup>2</sup>

#### **A. Use of Float**

Velocity of flow is measured simply by using any convenient type of floating material. A light object (float) is allowed to flow along a straight portion of the stream for a certain distance. Time taken by the float to traverse this distance is noted by a watch. Velocity of flow is obtained by dividing the total distance travelled by the float with time taken to cover this distance (Fig.2.4). Since, the float is required to travel along a straight line as far as possible, the traverse distance of the float is kept restricted within 20-30 m.

Average velocity of the stream is obtained by running a number of floats along different longitudinal section of the stream and taking their average. Since, the velocity of a stream also varies along its depth, mean velocity (V<sub>m</sub>) of flow is obtained by multiplying the average velocity with a factor of 0.85.

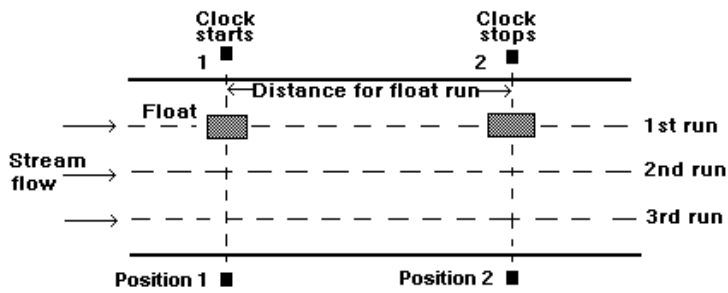

Fig. 2.4 Field layout for measuring velocity of a stream using floats

### B. Use of Current meter

Velocity of flow can also be measured by using a current meter or a flow meter. A typical current meter is comprised of a rotating impeller mounted on the nose of a streamlined main body containing electrical sensor to count the number of revolutions made by the impeller. The impeller rotates freely when submerged in flowing water for measurement of velocity (Fig.2.5). A current meter can be lowered at different depths by screwing it to a vertical dip rod.

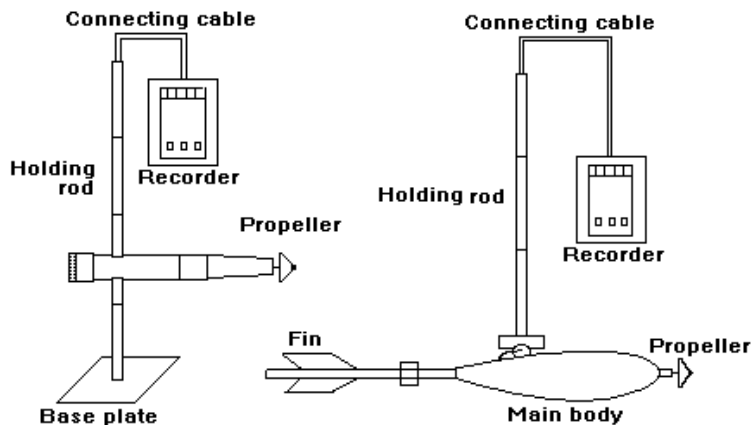

Fig. 2.5 Typical current meters for measurement of stream velocity

It should be noted that the velocity of flow in a stream is not uniform throughout its cross sectional area. It varies both along the width as well as the depth. Velocity of flow along the mid-course of the stream is greater than those closer to the banks. Similarly velocity reduces along depth. The highest velocity however is not at the surface but a little below the surface. Such distribution in velocity of flow develops



primarily due to the viscous drags along the banks and the bottom of the stream. For this reason, it is recommended that velocity measurements be carried out along a number of longitudinal lines in the stream and their average be taken to get the average velocity.

As the blades are placed against the flow direction, they rotate at a speed proportional to the velocity of flow. The electric counter records the total number of revolutions made over a time period (normally pre-set at 40 sec.) and transmits the data to a hand held recorder through a connecting cable. The total number of revolutions made for the particular time interval is then converted to velocity (m/sec) by using a calibration table or chart provided by the manufacturer for that particular current meter. For greater accuracy, velocities may also be recorded at two depths i.e. 0.2 and 0.8 times the total depth.

### ***C. Measurement of cross sectional area***

Simple method of obtaining cross sectional area (A) of a stream is to use a dip stick to measure the depths of the stream at fixed intervals along its cross-section. A rope or a cable with markings may be placed across the stream tied at the at both ends of the banks using stakes so as to facilitate taking measurements along a straight line of the cross-section. Use of dip stick or levelling staff is possible when the depth and flow in the stream are such that the depth can be gauged by wading through the water. Longer dip stick can also be used from a boat. Sophisticated method like echo sounding may have to be resorted to for very large rivers or lake having great spread and depth.

Sufficient number of points are to be selected in the stream to establish proper shape of the bed. In general, the intervals need not be smaller than 1/25th of the stream width in the case of regular bed profile and 1/20th in case of irregular bed profile.

Depths of water in the stream recorded at each point are then plotted in a graph sheet along the vertical lines after suitably fixing a horizontal and vertical scales (Fig.2.6). The line joining the plotted points give the bed profile of the stream. The area of the cross section of flow is then computed either by using a planimeter or simply by counting the number of full squares of the graph sheet falling within the

cross sectional area.

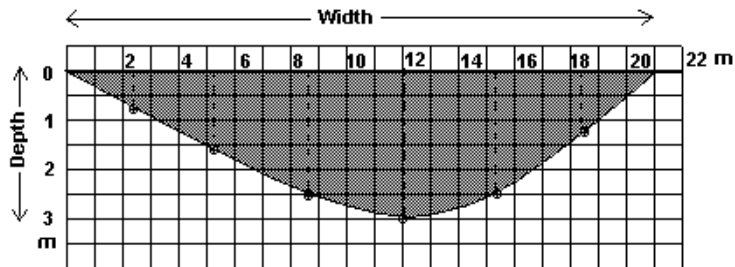

Fig. 2.6 Graphical method for computing cross-sectional area of a stream

The number of full squares multiplied by the area of each square, as obtained from the scales used in plotting, gives the cross sectional area of the stream. For the purpose of counting the number of full squares, all the incomplete squares are to be rounded up together to make as many near full squares as possible.

## 2.8.2 Hydrograph

Run-off measurements conducted at the outlet of a watershed during a particular rainfall (storm) is best represented in the form of a hydrograph. A hydrograph is the plot of discharge (stream flow) versus time (Fig. 2.7).

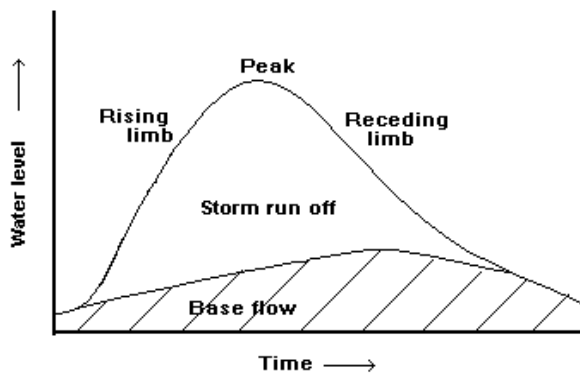

Fig. 2.7 A typical single peaked hydrograph

At the beginning, the stream may have just a base flow or no flow at all. As rainfall takes place, discharge (measured as water level) rises sharply. It reaches its peak value after a time called lag-time or time of concentration ( $t_c$ ). Thereafter, it

declines gradually as rainfall reduces. The decline begins at a slower pace as the intensity of rainfall reduces and becomes faster as soon as the rain stops. The decline again stabilizes at the initial level of flow.

As the second rain takes place, the hydrograph rises again. A hydrograph, therefore, may be single peaked or multiple peaked depending upon the complexity of the storm. The area under the hydrograph gives the volume of run-off. A high peaked hydrograph will indicate a watershed where run-off is rapid causing a great deal of soil erosion and vice versa.

## **2.9 EVAPORATION**

Evaporation is a natural process by which water continues to change into vapour state from its free surface. Major factors controlling rate of evaporation of water are the temperature, atmospheric pressure, wind speed, relative humidity, heat storage in water body and salinity of water. The last two factors, however, have relatively minor effects on evaporation and are taken into account only when a large surface water body is considered.

Potential evaporation is the total evaporation that would have taken place had there been sufficient water available for the evaporation. Average annual potential evaporation from large surface water bodies in different agro-climatological regions in India ranges from 1000 to 3500 mm per year.

### **2.9.1 Measurement of Evaporation**

Evaporation is expressed as the volume of water evaporated from an unit area in unit time and is measured as depth (mm) of water lost per day. Evaporation is measured directly by using US class A land Pan evaporimeter. This is a circular container made of unpainted GI sheet having 122 cm diameter and 25.5 cm in height (Fig. 2.8). A separate chamber with a gauge is provided within the Pan to enable observation of undisturbed water level. The Pan is filled up with water to a depth of about 18 to 20 cm.

The Pan is placed over a wooden grill (platform) 15 cm above ground for circulation of air below the Pan. The amount of water lost by evaporation from the

Pan during a given time interval (twice daily) is measured by adding known quantities of water to the Pan from a graduated cylindrical container till the initial level is restored. The depth of water required to be added from the graduated container to top up the Pan is the measure of evaporation. Evaporation divided by the time interval gives the rate of evaporation. As a normal practice, measurements of evaporation are carried out twice daily at 8:30 hr and 17:30 hr.

The modified class A pan used in India is known as Standard (ISI) or IMD (Indian Meteorological Department) Pan. The Pan is made of copper sheet of 0.9 mm thickness, tinned inside and painted white outside. In order to prevent birds to interfere with the water, a hexagonal wire netting (screen) of GI wire is placed on the top of the pan. The presence of the screen, however, reduces the evaporation rate to some extent. Experiments have shown that pan evaporation without screen is 1.44 times more than those with screens. Extent of evaporation from large water bodies like lakes, reservoirs etc. differ than evaporation from a Pan placed overland. Evaporation obtained from a land Pan is modified to obtain lake evaporation by using the following relationship.

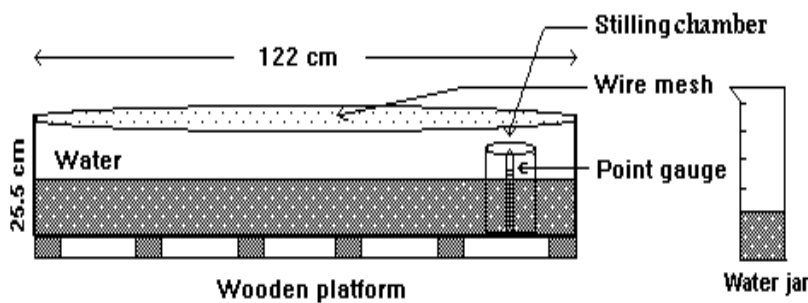

Fig. 2.8 A modified class A land pan evaporimeter

Lake evaporation  $= C_p \times$  Pan evaporation

Average value of  $C_p$  is taken as 0.7 for class A land pan and 0.8 for modified class A pan.

## 2.10 EVAPO-TRANSPIRATION

Transformation of surface water into atmospheric vapour also takes place through the process of transpiration by plants. The combined effect of evaporation and transpiration is known as evapo-transpiration (ET). The quantum of water actually consumed by plants for their metabolic activities is very negligible which is known as consumptive use (Cu). Evapo-transpiration include all water consumed by plants (Cu) plus the water evaporated from the bare soil and water surface from the area under crop, if any. In fact, direct evaporation from cropped area is also necessary for cooling plant bodies. In fact, if evaporation is reduced due to absence of near surface moisture in the cropped area, transpiration is increased correspondingly as is found in the case with drip irrigation. When evapo-transpiration data are not readily available, it is convenient to compute consumptive use (Cu) by using Blanny-Cridle formula (Michael, 1978) and is taken equal to ET.

## **2.11 INFILTRATION**

Water entering the soil from the ground surface is commonly referred to as infiltration. The maximum rate at which water enters the soil zone is the infiltration capacity. Factors affecting infiltration rate are intensity and duration of rainfall, texture, structure, thickness of soil, temperature, vegetative cover, land slope, land use, antecedent soil moisture content and depth to water table. As rainfall continues, infiltration replenishes the soil moisture first and the excess water start moving downwards by the force of gravity to recharge the ground water. Initial rate of infiltration is therefore, found to be relatively high which decreases gradually and finally stabilize at a fairly steady state even, if the rainfall continues.

Infiltration takes place at its capacity rate when the intensity of rainfall is equal or greater than the infiltration capacity. If, rainfall is less than the capacity rate, the infiltration approximately equals to the rainfall rate. Infiltration is measured in the field by using infiltrometer.

### **2.11.1 Tube Infiltrometer**

A tube infiltrometer is a metal tube, about 22.5 cm in diameter and 60 cm long. The tube is driven to the ground, as vertically as possible, to the depth up to which the infiltration is to be measured, leaving a small portion above ground. Water is

poured into the tube to a fixed depth and is allowed to infiltrate. Water required to be added from a graduated container into the tube at regular time intervals so as to maintain the initial level, is the amount of infiltration. Infiltration divided by time is the infiltration rate which is normally expressed in cm/hr.

Infiltration measurement test should be conducted upto a minimum period of 6 hours. The depth of water (cm) infiltrated during each time interval is then converted for a convenient time interval i.e per hour. The infiltration rate (cm/hr) is then plotted against the corresponding time intervals to give graphical presentation of infiltration rate.

In a double ring infiltrometer, two concentric rings 22.5 and 90 cm in diameter are driven, as vertically as possible, into the ground up to a depth of 15 cm with minimum disturbance of the soil surface. Water is then poured between the two rings to a particular depth. As infiltration continues, water at regular time intervals is added from a graduated container to maintain the initial level. The depth of water required to be added at the end of each time interval is the infiltration rate. The purpose of using the outer water tube is to facilitate water to infiltrate vertically downwards without much side wise spread.

Rate of infiltration varies exponentially with time which means that while the initial rate of infiltration is relatively high, the rate slows down in course of time. Infiltration rate is categorised as :

2.5 to 12.5 mm/hr	:	Low
12.5 to 25.0 mm/hr	:	Medium
> 25.0 mm/hr	:	High

## **2.12 EFFECTIVE RAINFALL**

When rainfall is very little say to the order of few mm, it barely moistens the soil and subsequently gets evaporated . Such rainfall has no use to crops. Also in case of concentrated heavy rainfall, major part of the water goes away as surface run-off and not available to plants. The useful part of the rainfall that is available for in situ crop production is the effective rainfall. It does not include water lost due to surface run off, deep percolation below root zone and the moisture remaining in

the soil after crop harvesting. Estimation of effective rainfall can be made by using standards tables when the mean monthly rainfall and mean monthly Pan evaporimeter data are available (Michael, 1978). While determining irrigation requirement of crops, the effective rainfall is to be subtracted from the total irrigation requirements of the crops.

## 2.13 WATER BALANCE

### 2.13.1 Climatic Water Balance

Climatic water balance of an area refers to the balance between incoming water through precipitation in one hand and the outgoing water through evapo-transpiration on the other. The quantum of evapo-transpiration is related to the extent of area under vegetative cover. Potential evapo-transpiration is the amount of water that would have evapo-transpired from a well vegetated area, had the soil moisture been always available in sufficient quantity for this purpose. Soil moisture continues to contribute towards evapo-transpiration till it depletes beyond a level known as the wilting point.

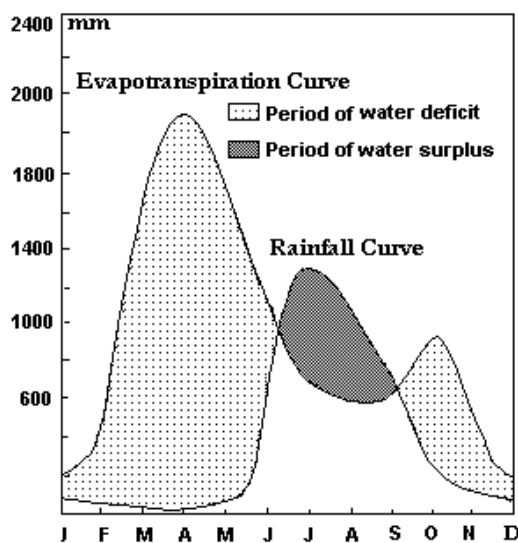

Fig.2.9 Rainfall - Evapotranspiration plot (climatic water balance)

A graphical plot of monthly precipitation versus potential evapo-transpiration (PET) of an area shows clearly the period when precipitation exceeds PET and

when the available water from precipitation is less for meeting the evapo-transpiration needs (Fig. 2.9). While the former is the period of excess water for crop growth as well as for soil moisture recharge, the later indicates period when soil moisture stress begins and exceeds the critical soil moisture availability (wilting point).

Study of the climatic water balance in a region is useful in understanding the scope of raising rainfed crops and in ascertaining the minimum irrigation facility required for providing supplementary irrigation including events of a departure from normal rainfall. Normally, quantum of rainfall during a rainy season remains higher than that of total PET. But, it is possible that due to erratic rainfall, PET even during the rainy season, may temporarily exceed precipitation, causing sufficient stress in soil moisture. For growing assured Kharif crop, keeping provision of one supplementary irrigations therefore is necessary.

### **2.13.2 Static Water Balance**

Static water balance deals with estimation of all water entering into and leaving from a watershed preferably on an annual basis. Water balance of a watershed in its simplest form is given by:

$$\text{Precipitation} = \text{Run off} + \text{Evapo-transpiration} + \text{Change in Storage}$$

All water from precipitation that remain within a watershed after run off has taken place, is storage. In a watershed, water remains in storage as surface water, groundwater and soil moisture which are dynamic in their occurrence and also interact amongst themselves. Change in storage would be the difference in volume of water estimated at any given time of the current year with that of the corresponding time of the previous year. This gives an indication of whether the water resources in a watershed is over-exploited or under-exploited. Storage is estimated using the above equation in which Precipitation is obtained by actual measurements and Run-off and Evapo-transpiration are computed analytically.

Similarly, we can have a static water balance for a village. This would basically mean estimating the water Inputs of the village. Inputs are the amount of rainfall consumed directly by plants, water stored in the village harvesting structures, soil



moisture gain and imported water, if any. If the inputs are more than the village requirements then the village is positive in water balance and vice versa. Similarly, we can easily work out the drinking water balance study for a village or domestic water balance study for a household.

**Problem 2.3**

A watershed extending to 2500 ha, receives 800 mm of mean annual rainfall. The Kharif (groundnut) cultivation is 1500 ha and Rabi (wheat) extends to 1200 ha. The watershed also has 50 ha of dense forest and 5 ha under a perennial tank. The run-off coefficient has been estimated as 0.3. The crop coefficients for groundnut and wheat measured at a nearby research station are 0.7 and 0.6 respectively. Total annual potential evaporation in the watershed is 2000 mm and those for Kharif and Rabi seasons are 500 mm and 700 mm respectively. Prepare an approximate static annual water balance of the watershed.

**Solution 2.3**

I. Estimation of Run-off

Volume of rainfall = Area x mean rainfall = 2500 x 0.8 = 2000 ham = 20 Mcm

Volume of run off = Volume of rainfall x Run off coefficient = 20 x 0.3 = 6.0 Mcm

II. Estimation of Evapo-transpiration

Source	Area ha	Season	Pot.Evp m	Crop factor	Total Cu Ham
Groundnut	1500	Kharif	0.5	0.7	525
Wheat	1200	Rabi	0.7	0.6	504
Forest	50	Perennial	2.0	1	100
Tank	5	Perennial	2.0	1	10
Monsoon evp. from rest of areas	945	Kharif	0.5	0.2	94.5
Total					1233.5 = 12.33 Mcm

Precipitation = Run off + Evapo-transpiration + Storage

20.0 = 6.0 + 12.3 + Storage

Storage = 20.0 - 18.3 = 1.7 Mcm

## **3.0      *Groundwater and Wells***

---

### **3.1    DISTRIBUTION OF SUB-SURFACE WATER**

Water occurring in the subsurface formations can broadly be divided into two horizontal segments. The upper horizon is the *zone of aeration* and the lower segment is the *zone of saturation* (Fig.3.1). The zone of aeration remains filled partly with air and partly with water. The water occurring in this zone is known as soil water. In the zone of saturation, all the pores remain saturated with water. Water occurring in this zone of saturation is known as groundwater (GW). The upper surface of the zone of saturation is the water table.

A third zone called unsaturated zone often occurs between the zone of aeration and the zone of saturation particularly when the water table is deep. This intermediate unsaturated zone however gets saturated temporarily during rainy season when GW receives its recharge from rainfall. The zone of saturation containing GW on the other hand extends downwards till the bed rock in hard rock areas or till an impervious clayey layer is encountered in alluvial area. More such saturated zones may occur underneath the first one in case of multi-aquifer system common to thick alluvial deposits.

Soil moisture i.e the water in aeration zone can occur as gravitational water, capillary water and hygroscopic water.

#### **3.1.1 Gravitational Water**

When surface water infiltrates into soil, it start occupying all the pore space and saturates the soil. After the soil is completely saturated, the excess water called gravitational water starts moving downwards due to normal force of gravity to finally join the saturated zone. Movement of gravitational water down the soil profile depends upon the permeability of the sub stratum and depth to the water table. Gravitational water though useful to plants, normally does not remain in

place for long. However if it remains in the soil too long, serious damage may take place to most crops due to lack of air (oxygen) in the soil.

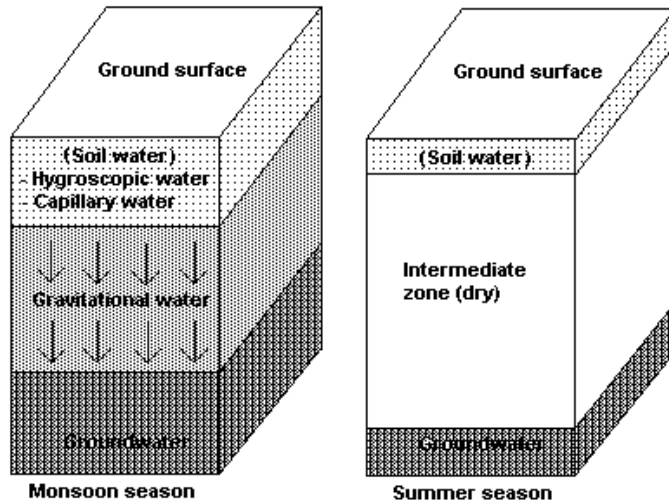

Fig. 3.1 Schematic diagram of sub-surface distribution of water

### 3.1.2 Capillary Water

After draining of the gravitational water, certain amount of water will remain held within the soil pores due to capillary forces. This water retained in the soil pores by the force of molecular attraction is the capillary water. This water is held in the pore space as continuous film and can be removed by applying force greater than that of the capillary force. A major part of this water is utilized by plants.

### 3.1.3 Hygroscopic Water

Hygroscopic water is that part of the water which a dry soil will absorb in order to reach to the static state with the atmospheric water (vapour). It is held by the force of molecular attraction and can be removed only by heating. Hygroscopic water is not available to plants.

## 3.2 AQUIFER

Water occurring in the pores and interstices of sub-surface formations to its level

of saturation is groundwater. Groundwater occurs much below the zone of soil moisture. A porous and permeable formation capable of holding and transmitting sufficient quantity of water under gravity (normal field condition) is an *aquifer*. Thick sand formation, weathered hard rock of granular consistency, fractured hard rock, shear and contact zones between two hard rocks etc. form good aquifers. A formation that can hold water but does not transmit water is an *aquiclude* e.g clay. A formation that neither holds nor transmit any water is an *aquifuge* e.g compact Granite, compact Basalt etc.

### **3.2.1 Unconfined Aquifer**

An aquifer whose upper surface is hydraulically open to atmospheric pressure (porous) but the bottom surface is confined by an impervious formation like a clay horizon or the massive bed rock, is known as an unconfined or *phreatic* or water table aquifer. As water in unconfined aquifer is open to atmospheric pressure, it moves naturally under the normal force of gravity.

Consolidated formations (hard rocks) normally do not have much pore spaces at the time of their formation. Over long years, such formations starts getting weathered beginning from the exposed surface downwards. Weathered hard rock eventually gets reduced to granular consistency developing sufficient pore spaces (secondary porosity) within the weathered portion. Such weathered hard rock in many parts of the country is known as *murrum*. Hard rocks also develop some joints and fractures due rapid cooling, intrusive like rising dykes and subsequent weathering. Groundwater in hard rock areas, therefore, occurs mostly under water table condition in the upper weathered mantle and sometimes under semi confined condition in the deeper fractured zones. Extensive fracture zones in the vicinity of large water bodies sometimes give rise to the existence of highly yielding fractured zone aquifer.

### **3.2.2 Confined Aquifer**

Confined aquifers occur within thick alluvial deposits of large river valleys. A confined aquifer is one which is bounded by impervious layers at both its upper and lower surfaces. A sand formation which is sand-witched between two clay formations is a confined aquifer. Confined aquifers receive recharge regionally

from a far away location where the formation is exposed to some surface water body. Groundwater in a confined aquifer occurs under hydrostatic pressure originated due to the head created by the difference in elevation between the recharge area and the aquifer being tapped. When the upper confining layer is pierced by a bore hole, water rises in the bore above the aquifer to a level equal to the existing hydrostatic head. The final water level in the bore hole is called *piezometric surface* or *artesian level*. When the *piezometric surface* rises above the ground level then the well is known as artesian or a flowing well.

In areas underlain by thick alluvial deposits of alternating sand and clay formations e.g Indo-Gangetic plain, water occurs both under confined and unconfined conditions. Amongst various alluvial deposits, coarser the grain size, more yielding the formation (aquifer) is. Thus gravel and coarse sand formations form the most prolific aquifers. Confined aquifers are generally rare in hard rock areas but typical geological distribution sometimes gives rise to the formation of confined aquifer in areas with multiple consolidated formations e.g basalt overlying sandstone or limestone or in contact zones of Basalt layers usually separated by a red soil like material called *red bowl*. An aquifer confined or unconfined will yield sufficient GW consistently only when they receive sufficient recharge water.

### **3.3 WATER TABLE**

In large alluvial tracts, like in Indo-Gangetic alluvial plain, water occurs under both unconfined condition in the uppermost clay-sand aggregate and also under confined condition in deeper confined aquifers. As many confining clay horizons occur in series of discontinuous bands, the underlying sand aquifer in such situation behaves partly as confined and partly as unconfined aquifer and is referred commonly as semi-confined aquifer. Sometimes, presence of a clayey layer near the ground surface can create a localised unconfined aquifer giving rise to a water table which occurs above the regional water table. Such localised water table is known as perched water level. Perched aquifers do not sustain regular pumping.

It is usually the deep confined aquifers which are the major source of GW. Unconfined aquifers in near surface sand formations e.g old river beds also yield sufficient quantity of GW through open dug wells. In hard rock areas, it is the

unconfined aquifer (weathered zone) receiving sufficient recharge, yield most water when tapped through dug wells.

### **3.3.1 Static Water Level**

Water table is the upper most surface of the saturated zone of an unconfined aquifer. Thus, when an open well is dug into an unconfined aquifer, the water from the aquifer starts entering the well and a water level starts building up within the well. The water level will stop rising further (i.e water will stop entering the well), as soon as the water level in the well coincides with top of the saturated zone outside the well. The water level now observed in the dug well is the water table.

Any water level observed in a well is not always the water table. For example, if a well has been pumped for a while and the water level in the well is still in the process of recovery, the level observed would not be the water table till it reaches the zero pressure surface i.e equal to the upper most surface of the saturated zone outside the well. Therefore, the terms static water level and dynamic water level are used to distinguish water table from any other water level. The *piezometric surface* of a confined aquifer is the water level that is observed in a tube well tapping a confined aquifer. This level which rises within the bore as per the hydrostatic pressure within the aquifer tapped, will also be the static water level for the well (aquifer) provided there had been no lowering due to pumping.

### **3.3.2 Fluctuation in Water Table**

Water table experiences a seasonal fluctuation. As measured below ground level (bgl), it is shallowest after rainy season (post monsoon period) and deepest during the summer months (pre monsoon period). Fluctuation takes place mostly due to recharge to and withdrawal from aquifers. Immediate recharge takes place directly from rainfall, and subsequent recharge is received from nearby surface water bodies (tanks, streams etc.). Sometimes groundwater may also flow conversely from an aquifer to a nearby stream or river. Such outflow of GW in streams are the origin of base flow seen in many seasonal streams even during the summer months.

In hard rock areas, many dug wells go dry during pre-monsoon (summer) period

which rejuvenate again during monsoon due to recharge received from the rainfall. The water table in hard rock areas thus fluctuates naturally in a seasonal cycle. However, in thick unconfined and deep confined aquifers when the withdrawal rate is higher than the recharge received by the aquifer, the water level in the area shows a declining trend. The GW in such situation is known to be over-exploited.

### **3.3.3 Factors Affecting Depth of Water Table**

As aquifers occur regionally, the water table also occurs regionally with some exceptions. For this reason, some water is always found in most wells particularly during rainy season, even if constructed at an unfavourable site. Depth to water table depends upon the following factors.

#### **A. Topography**

Topography plays an important role in the occurrence of GW particularly in the hard rock areas. It is obvious that water table would be at a shallower depth in a valley or depressed area (topographic low) than in an area with higher ground elevation. The shape of the regional water table below the ground level, however, is not horizontal. The shape of the water table has a tendency to follow the shape of the ground topography. Thus two adjacent wells located at ground elevation difference of say 10 m will not have their water tables with level difference of exactly 10 m but little less say 7 or 8 m.

#### **B. Thickness of aquifer**

Thickness of an unconfined aquifer in a hard rock areas will be governed by the thickness of the weathered zone. If, the thickness of the weathered zone is small, the aquifer will get filled up sooner due to recharge and the water table will rise faster giving rise to a shallow water table. Water level rise in a thicker and more permeable aquifer is relatively slower. Shallow water level observed in a dug well, therefore, does not necessarily mean that the well has more yield than another one with lower water table but thicker aquifer.

#### **C. Permeability of aquifer**

Permeability of a formation is the ease with which water flows through it. Higher the permeability of a formation, more water it would be able to store and transmit. As water transmits rapidly through a formation with high permeability, the water level fluctuation in a well located in a more permeable aquifer will be lesser than that in an aquifer with low permeability. Rise in the monsoon water level in a well, tapping a less permeable aquifer will be higher resulting a shallow water table than one tapping a more permeable aquifer. The water level in a less permeable aquifer, however, will recede much faster with the advent of dry season.

#### **D. Quantum of recharge**

It is obvious that an aquifer will take more intake of water, when the supply of recharge water is more provided that additional storage space is available within the aquifer. The supply of larger quantity of recharge water like what happens in a high rainfall year gives rise to a larger rise in water table.

#### **E. Seasonality**

As mentioned earlier, water table experiences a cyclic fluctuation with respect to the season. Water table reaches to its deepest level during the summer months and to its highest level (shallowest) during monsoon. While the rise in water table takes place due to recharge during monsoon period, the recession takes place due to extraction of groundwater and sub-surface flow into the streams and rivers.

#### **F. Quantum of extraction**

Groundwater extraction can influence the depth of watertable more than any of the above mentioned factors. As the annual extraction in every passing year exceeds the corresponding annual recharge, the water table recession takes place. Groundwater in such area is known to be over-exploited or GW mining is said to be taking place in the area.

### **3.4 GROUNDWATER MOVEMENTS**

#### **3.4.1 Porosity**



Unconsolidated formations and weathered product of consolidated formations contain sufficient pore space within them to function as an aquifer. Porosity is the measure of pore space in a formation and is expressed by the ratio of the total volume of pore space (v) per unit volume of the rock formation (V) i.e

$$\text{Porosity (\%)} = (v/V) \times 100$$

All water occupying the pore space however do not drain out under normal gravitational force (free flow). While the water that flows out as free flow (as in a dug well) is known as specific yield, the water that remains held in the pore space under capillary force is known as specific retention. Thus

$$\text{Porosity} = \text{Specific Yield} + \text{Specific Retention}$$

Porosity of a granular formation depends upon its grain size, their orientation, compaction and presence of cementing material. Normally, coarser the grain size of a formation, higher is the yield potential of the formation (aquifer). Porosity (secondary porosity) of a weathered hard rock depends upon the degree of its weathering and upon the extent of joints and fractures.

### 3.4.2 Permeability

Flow of ground water through a porous media is controlled by Darcy's law which states that the rate of flow of water through a porous media is directly proportional to the cross sectional area of the flow and the hydraulic gradient under which the flow moves. Thus referring to Figure 3.2, we have

$$Q = KA\delta h/\delta l$$

Where,

- Q = Rate of flow through porous media, cu.m/sec
- K = A constant known as coefficient of permeability, m/sec
- A = Area through which the flow takes place, sq. m
- h = Head (height) of the flow, m
- l = Length of the flow, m

$$\delta h / \delta l = \text{Hydraulic gradient}$$

If we consider an unit cross sectional area i.e  $A = 1$  and an unit hydraulic gradient i.e  $h/l = 1$  then the above equation becomes  $Q = K$  i.e Flow = Permeability (for an unit area under unit head)

Since flow of water through porous media is quite slow, the permeability coefficient  $K$  is normally expressed in m/day. Permeability of surface layer varies in the range of 0.8 - 1.2 m/day which may extend to 7 - 8 cm/day for sandy formations. Flow through fractured rocks, however, does not follow Darcy's equation and is similar to the gravity flow through open conduit.

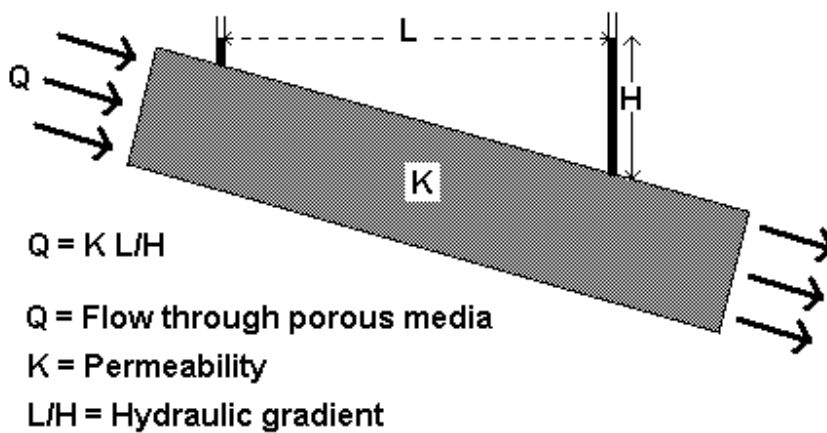

**Figure 3.2 Flow of groundwater through porous media**

Both the interventions like artificial recharge (intake) and large scale pumping (extraction) tend to modify the shape of the regional water table forming a mound or a depression respectively. On cessation of these interventions the water table gradually start dispersing, the rate of dispersion is proportional to the permeability of the formation.

### 3.4.3 Aquifer Characteristics

The yield potential of an aquifer is judged by two important characteristics of the aquifer namely its *Storage Coefficient* (S) and *Transmissibility* (T). Storage

coefficient is the volume of water, a aquifer would release (or take into storage) under a change of unit head. Storage Coefficient for unconfined aquifer is its specific yield and depends on porosity. *Transmissibility* is the product of permeability and thickness of an aquifer. *Transmissibility* is considered as an important aquifer parameter as both the thickness and permeability of the aquifer are taken into consideration.

#### **3.4.4 Inter Flow**

The term inter flow is used at times to describe the dynamics of exchange of flow between surface water and groundwater. As water table tend to follow the topography and flows slowly along the hydraulic gradient, a perceptible lateral movement in groundwater does take place which is commonly referred as sub-surface flow. When the slope of the ground surface is such that it intercepts the water table, groundwater flows out to the surface giving rise to the formation of a natural spring. Such springs are quite common in hill areas.

A stream can receive water from groundwater aquifer when the depth of water table occurs at a level higher than that of the stream bed. The base flow seen in some seasonal streams even during the summer months come from groundwater contribution. Conversely, if the depth of water table lies below the water level in a stream or a river, groundwater receives recharge from these water bodies.

### **3.5 GROUNDWATER DEVELOPMENT**

#### **3.5.1 Selection of Well Site**

A careful selection of well site is required to ensure that the desired quantity of water is available within a reasonable depth. Proper selection of well site becomes all the more important where the cost of construction of a well and the chances of failure are high. Well site selection also becomes necessary in areas where poor quality groundwater occurs in pockets.

In areas underlain by thick alluvial deposit like in the Indo-Gangetic plain, hydrogeological considerations of a well site is normally ignored as a productive sand aquifer is eventually encountered at one depth or the other thus eliminating

the chances of a complete failure. Moreover, as the deeper aquifers are regionally extensive, the knowledge of strata encountered in one borehole is extended to another to be drilled in the vicinity expecting a similar distribution of formations (strata).

It is, however, the hard rock and other geologically complex areas where careful selection of well site allows one to extract more water than others. Large number of drinking water bore wells fitted with hand pump are installed in our country generally without paying much attention to Geohydrological considerations. This has been possible because water requirements for such drinking water wells are very low and most bores drilled up to a certain depth (>35 m) normally yield some quantity of water capable of meeting the minimum discharge requirement of 200 litres per hour (lph), acceptable for installation of hand pumps.

The commonly applied scientific method of investigating the yield potential of a proposed well site is the use of resistivity survey. The method of investigation is known as Vertical Electrical Sounding (VES). It is a low cost field technique which can be conducted by a team of four surveyors within a few hours. Other sophisticated techniques e.g seismic refraction survey, electromagnetic survey, Remote sensing mapping etc. are applicable for scientific regional studies.

Well site selection for farmers in the villages underlain by hard rock areas and areas with deeper water table, are done mostly by local experts either through *dowsing* or simply by applying basic geohydrological criteria as assimilated through observations and common sense. Observation of topography, nearness to the drainage lines and water bodies, thickness of soil profile (weathered zone), yield of adjacent wells, vegetative growths etc. are used in a judicious combination. Wells dug at topographic lows (depressions) having greater degree and thickness of weathering will normally yield more water than wells in the higher reaches in the area. Water available in some wells located in the hill tops are due to the recharging by rainfall of the near surface fractured rock aquifers which, however, sustain only the drinking water needs.

It is the nature of the aquifer tapped and not the type of well which is responsible for yield. A well is merely an extraction structure. Choice of the type of a well will depend on factors like depth of the aquifer, availability of technology for its

construction, cost and convenience. Dug wells are ideal groundwater extraction structure for shallow unconfined aquifers. These structures are preferred by farmers not only because these have considerable storage capacity but also can be constructed and deepened in phases using local expertise.

### **3.5.2 Dug Well**

Dug wells are most commonly used water extraction structures. These are used normally to tap shallow unconfined aquifers. In hard rock areas, the weathered zone acts as a water table aquifer and yields according to its degree of weathering and extent of recharge it receives. In order to get maximum water, a dug well should be located in a topographic low and be deep enough to tap the entire thickness of the saturated zone.

A dug well may dry up during summer when either the water table recedes below the bottom of the well or when the entire saturated zone dries up. Deepening of a well below the depth of the saturated zone will not increase its yield but the extra space will function merely as a space for extra storage. The dry well may again rejuvenate back to life during monsoon period due to rising of the water table if sufficient recharge is received from rainfall.

### **3.5.3 Tube Well**

Tube wells are constructed normally to tap deep confined aquifers. Tube wells are constructed by adopting suitable drilling techniques as applicable to the rock type under consideration. Thus mud rotary drilling is used in unconsolidated (alluvial) formations where the cutter is rotated manually or using a diesel engine. The drill cuttings are flushed out by mud circulation using a mud pump. Casing pipe is inserted throughout the depth of the bore hole. The casing pipe resting against the aquifer is provided with slots to act as a filter (screen) so that sand free water enters into the tube well. Diameter of the upper part of the casing pipe is kept larger than the slotted pipes to facilitate lowering of the pump in to the tube well. High yielding tube wells are also provided with a gravel envelop between the aquifers and the screen and a cement sealing at the top to prevent pollution.

In hard rock areas, bore wells are drilled with the intention of tapping deep seated

aquifer formed due the presence of fractured zone, shear zone, contact zone etc. Groundwater in such zones normally occur under semi-confined conditions. As the existence of these zones are limited, all bore holes drilled in a hard rock area will not be successful. Bore wells in hard rock areas should, therefore, be drilled only after careful investigation of the site. Bore wells are also drilled in semi-consolidated formation where groundwater may occur under unconfined condition but with a very deep water table.

Drilling in hard rock is done by hammering and cutting (compressor driven down the hole hammer) with tungsten carbide bits or simply by cutting (cable tool, calyx, diamond drilling etc) holes into the ground. The drill cuttings are flushed out either by using compressed air or by scooping by tapered pipes (bailers). Casing pipes are inserted only upto the top weathered zone (overburden) to prevent collapsing. Casing pipes are not required for the rest of the bore hole as hard rocks do not normally collapse.

#### **3.5.4 Cavity Well**

Cavity wells are shallow, low cost, moderately high yielding tube wells found in large numbers in Indo-Gangetic plain of Bihar, Uttar Pradesh, and Punjab. The special feature of a cavity well is that the casing pipe do not use any filter or screen. Construction of cavity wells require the presence of a hard clay formation at the top not thicker than 20 m followed by a sand formation (aquifer) underneath. Blank casing pipe is lowered till the bottom of the hard clay formation by hand boring. The *piezometric surface* of the underlying sand aquifer rises in the bore hole reaching to a level which is within the permissible suction lift of a centrifugal pump. A centrifugal pump directly coupled to the casing through a non-return valve is then run to develop the well for many hours. Sufficient quantity of sand is brought out of the aquifer together with the flowing water thus forming a cavity in the aquifer just below the pipe. The cavity normally does not collapse because the overlying formation is hard clay. Development of the well is complete when the pump starts giving uninterrupted supply of sand free water.

#### **3.5.5 Dug cum Bore Well**

In an area where both shallow unconfined and moderately deep confined aquifers

are present, GW is tapped most profitably by constructing a dug cum bore well in which vertical bores are drilled from the bottom of a dug well. While the dugwell taps water from the shallow unconfined aquifer, the bore well taps deeper confined aquifer, the *piezometric surface* (water level) of the deeper aquifer rises high enough to reach the dug well. Water received from both the aquifers as stored in the dug well is pumped out by using an ordinary centrifugal pump.

In an area underlain by a monolithic hard rock formation (granite, basalt), vertical bores taken at the bottom of a dug well usually do not add to any extra yield. Horizontal bores in a dug well in hard rock areas, could be useful provided they are drilled at a depth below the static water table and that they have along their path, tapped some additional fractures which had poor or no hydraulic continuity with the well. Horizontal bores are useful in draining the aquifer surrounding the well much faster than it would have flowed naturally.

### 3.6 WELL HYDRAULICS

When a tube well fully penetrating an unconfined aquifer is pumped, the static water level starts declining. The difference of level between the static water level and the pumping water level within the well is known as drawdown. As pumping continues and drawdown increases, water starts entering into the well from the aquifer and an expanding *cone of depression* is formed around the well (Fig.3.3).

The initial rate of drawdown is faster as pumping takes out primarily the stored water from the well. As pumping continues, the aquifer starts releasing water into the well and the drawdown decreases exponentially. If at any point of pumping, the rate of water extraction from the well becomes equal to the rate of water entering into the well from the aquifer, then the drawdown stops. The well is then said to be at a steady state condition. As water drains into the well from the aquifer, a cone of depression of the water table takes place due dewatering of the aquifer.

The amount of draw down (s) in a well under steady state condition is given by:  
$$s = 2.3 Q \log (R/r_w) / 2\pi T$$

Where,

- $Q$  = Steady state discharge, cu.m/hr  
 $T$  = Transmissibility of the aquifer, sq.m/hr  
 $s$  = Drawdown in the well, m  
 $R$  = Radius of influence, m  
 $r_w$  = Radius of the well, m

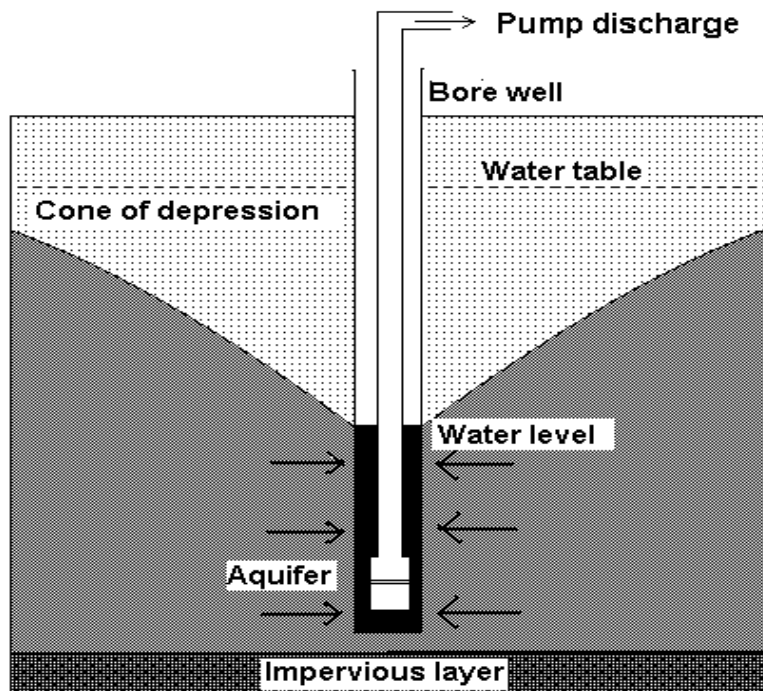

Figure 3.3 Dewatering of an aquifer during pumping of a tube well

However, in a well fully penetrating a confined aquifer, the flow is said to be in an unsteady state and the equation controlling the drawdown is different.

### 3.6.1 Effect of diameter in well yield

While the quantity of stored water in a well depends on the size of the well, its yield is related to the *Transmissibility* (Permeability x thickness) of the aquifer it taps. Referring the above equation for steady state flow in a well penetrating fully an unconfined aquifer, we find that the yield of a dug well ( $Q$ ) varies logarithmically with the radius of the well ( $\log R/r_w$ ). Hence, yield of a well does



not become double when the diameter of the well is doubled but increases only marginally (logarithmically). Similarly, deepening of a dug well may or may not increase its yield depending upon whether the formation dug out is a part of the aquifer or not. Deepening however, will result in an increase in storage capacity (dead storage), when it does not tap any additional aquifer zone.

### 3.6.2 Specific Capacity

An idea about the yield of a well is obtained by its Specific Capacity value. Specific Capacity of a well is the ratio of the discharge ( $Q$ ) of the pump and the corresponding drawdown ( $s$ ) observed in the well i.e  $Q/s$ . Higher the value of specific capacity of a well, better is the yield potential of the well and *vice versa*. However, it should be noted that Specific Capacity is a function of time and its initial values get influenced by the quantum of water storage in the well. Effects of storage and time on Specific Capacity, however, are usually negligible.

Specific Capacity values of dug wells obtained after the lapse of certain time period say at the end of 1 hour pumping would be more dependable to compare yield potential of different dug wells.

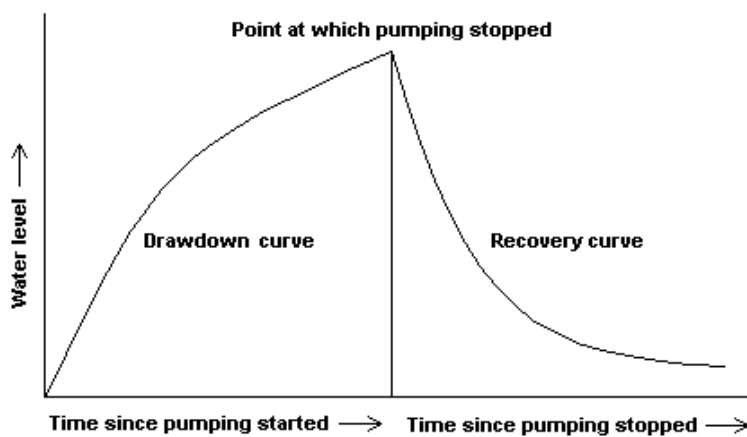

Fig. 3.4 Curves showing the rates of drawdown and recovery in a pumped well

### 3.6.3 Recovery Method

Yield of a well can, conversely be measured by its rate of recovery. Water level in a well begins to recover as soon as pumping is stopped. Rate of recovery in water level is not linear but varies with time (exponential) which means that higher the draw down, faster will be initial rate of recovery. Rate of recovery slows down with time as the recovery continues. In fact the last 10% recovery takes much longer time than the earlier 90 % of recovery. As the recovery brings the water level to the static water level, the flow into the well will stop.

The modified Specific Capacity based on recovery data as proposed by Slichter is given by

$$t = 2.3 A s / Q \log s / s'$$

Where,

t = Time of recuperation, min.

A = Surface area of the aquifer exposed in the well, sq.m

Q = Discharge rate of the pump, cu.m

s = Draw down in the well, m

s' = Residual draw down, m

r = Diameter of the well

When 90% recovery in a well has taken place, it is assumed that for all practical purposes, near complete recuperation has taken place. The ratio of the drawdown (s) and the residual draw down (s') then becomes 10. The above equation under this condition reduces to

$$t = 2.3 \pi r^2 s / Q \log 10$$

$$Q/s = 2.3 \pi r^2 / t$$

The above equation gives the Specific Capacity (Q/s) i.e the yield potential of a dug well based on its recovery data.

### 3.6.4 Constant Discharge Test

Pumping tests are carried out for ascertaining the yield potential of a bore well (tube well) or to evaluate the aquifer parameters i.e *Transmissibility* (T) and *Storage Coefficient* (S) of the aquifer. The drawdown in the pumping well and also in another nearby well(s) (observation well) are recorded at suitable time intervals. A plot of drawdown against the corresponding time intervals is known as time-drawdown curve. Since the time-drawdown plot is curvilinear, it is customary to plot the time-drawdown curve of a pumping well in a semi-log paper with time in abscissa and drawdown in ordinate. The slope of the resulting straight line gives the value of aquifer Transmissibility. More accurate values of the aquifer parameters namely the *Transmissibility* (T) and *Storage Coefficient* (S) are obtained from the time-drawdown plots of the observation wells by using curve matching techniques.

### 3.6.5 Step Drawdown Test

Optimum yield of a well is the concept which takes in to account also the pumping cost. We are aware that as the head increases, the discharge of a pump reduces. But in order to maintain the requisite discharge an user may be encouraged to deploy a pump of higher Horse Power. Using more power than required which no doubt is wastage.

Optimum yield of a well is arrived at by conducting a “step draw down test” in the well. In this test, a bore well is first pumped at a very low and constant discharge rate for a fixed period of time say 1 hour in such a manner that the water level stabilizes at a shallow depth. The pump discharge is then increased to a medium rate of pumping so that water level falls further down but eventually stabilized at an intermediate depth. The next step is to increase the pump discharge further higher so that the water level again stabilizes at a lower level further down. More such steps can be conducted if possible. Each step is carried out for a fixed period of time and discharge during each step is kept constant. When the discharge versus steady state drawdown of the different steps are plotted, we get a parabolic curve as shown in Figure 3.5.

The curve indicates that the rate of fall of water level increases exponentially with increase in discharge. The point of tangent in the curve is the optimum yield of the

well. The optimum yield of the well would therefore be such that the pump discharges about 20 m<sup>3</sup> /hr of water so that the water level remains stabilized at about 10 meters of drawdown.

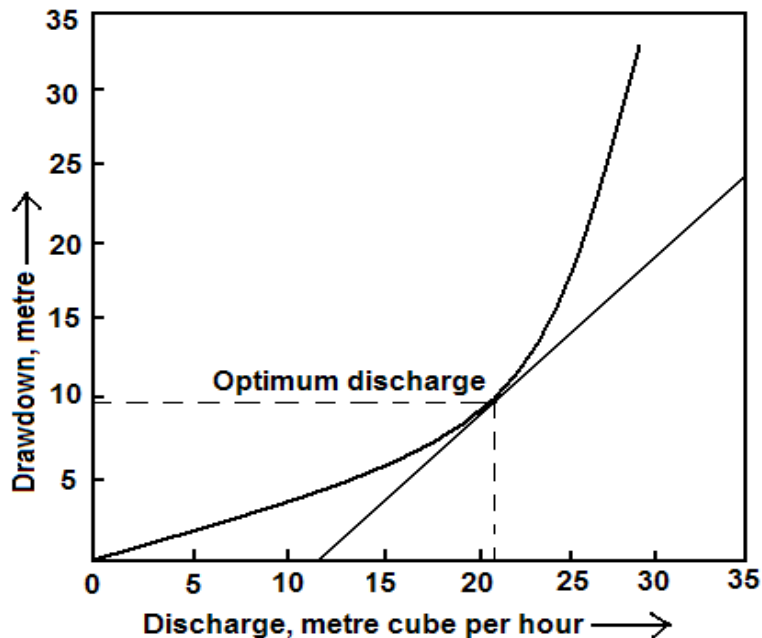

Figure 3.5 Optimum discharge of a tube well as obtained from step drawdown test

To obtain optimum yield from a bore well, the depth and discharge of the submersible pump within the bore are so chosen that the water level stabilizes at the optimum draw down level at which the pump is capable of running for 24 hours a day with highest efficiency and at the lowest operating cost. It is therefore recommended that in order to obtain the optimum yield which is different from the maximum yield, a pump need not be lowered to the maximum possible depth.

### 3.6.6 Interference Between Wells

As pumping continues in a well, the radius of influence i.e the cone of depression continues to expand. Therefore, when one of the two closely spaced well is pumped, the pumping also causes a minor lowering of the water level in the non-pumping well depending upon the extent of the cone of depression. Such lowering

of water level in one well due to pumping of another is known as well interference. When both the wells are pumped together, each one causes an additional drawdown in the other well. This is known as mutual interference of well. Total drawdown in a pumping well is the algebraic sum of its own drawdown plus drawdown caused by interference.

From the mutual interference point of view, the safe distance between two wells should be decided based on the expected discharge of each well and the permeability of the aquifer separating them. Higher the permeability, lesser will be the radius of influences and hence closer will be their safe or the non-interfering distance and *vice versa*.

### **3.7 WELL INVENTORY**

Existing wells are the source of a great deal of information about the Geohydrological set up of an area. Well inventory refers to the collection of relevant information from the existing wells. The information looked for, are the depth and diameter of the well, the geological formations encountered, the depth of water table, its present use, pumping pattern, rate of recovery, quality of the water etc. Inventories of a number of representative wells are the basic and most important step in understanding the GW condition of the area. Measurement of pre-monsoon and post- monsoon water levels from a number of selected observation wells aid in the preparation of seasonal water table contour maps useful for estimating average seasonal water table fluctuation. Such maps are useful not only in ascertaining the flow gradient and groundwater movement but also in estimating annual groundwater recharge.

#### **3.7.1 Well Monitoring**

In the context of Geohydrological studies, well monitoring refers to the periodical measurement of the water level and water quality from a number of identified wells to study the changes in these parameters. Measurements are normally carried out twice a year, once when the water level is deepest (pre-monsoon) and another when water level is shallowest (post-monsoon). Well monitoring helps in computing annual groundwater recharge, withdrawal from the wells and changes in water quality. Continuous monitoring of water level is achieved by installing

automatic water level recorder or a *piezometer* in a bore well. The resulting chart obtained from a water level recorder is known as the well hydrograph. A well hydrograph in conjunction with corresponding rainfall provide information about the extent of recharge received by the area from rainfall.

### **3.7.2 Water Level Measurement**

Measurement of the static water table from wells is the single most important activity in well monitoring. Many important decisions are taken based on depth of water table and its fluctuation. It is important that depth of static water table is measured properly. Most common error that takes place in water table measurement is the failure to distinguish between static water level (water table) and the dynamic water level. When a well is pumped, sufficient time should be allowed for water level to attain near full recovery before taking the measurement. Water level should preferably be measured early morning before the pumping is started and the well has undergone over-night recovery.

### **3.8 SAFE YIELD**

While the terms optimum yield and maximum yield are applicable to water wells, the term safe yield applies to an aquifer system. Optimum yield of a well is that yield where the drawdown stabilizes at that depth where cost of pumping is minimum. Optimum yield is represented by the point in the discharge-drawdown curve at which a line intersecting the curve forms the tangent (figure 3.5).

Maximum yield however involves pumping a well as long and as frequently as possible to extract maximum quantity of water. For example, many dug wells are pumped by most users to obtain the maximum yield. Maximum yield from a dug well is obtained first by pumping the well dry and then allow the well to recover its water level. As soon as a reasonable quantity of water is accumulated, the process is repeated.

Safe yield of an aquifer was defined initially as the limit to the quantity of water which can be withdrawn regularly and permanently without depleting the storage reserve. Safe yield was defined later as the rate at which water can be withdrawn from an aquifer for human use without depleting the supply to such an extent that

withdrawal at this rate is no longer economically feasible. While no well-defined cut-off level is mentioned in the first definition, the second one mentions about the suitability of water quality in terms of human use and emphasises economic criteria as the limit. Since groundwater recharge from rainfall is a seasonal phenomenon, the latter definition was expanded further by specifying the period of withdrawal as 1 year. Safe yield of an aquifer system should, therefore, not

- exceed average annual recharge;
- lower the water table so that the permissible cost of pumping is exceeded;
- lower the water table so as to permit intrusion of water of undesirable quality;
- disturb the existing water use rights.

When annual extraction of groundwater from an area (groundwater basin) exceeds the extractable annual recharge, GW in the area is said to be over-exploited. When the GW in an area is found to be over-exploited, one or more of the following corrective measures should be undertaken with immediate effect.

- Conservation of water by preventing waste in use.
- Proportionate reduction of extraction from the existing production wells.
- Prohibition for further construction of additional wells.
- Promote large scale artificial groundwater recharge measures.

### **3.9 GROUNDWATER RECHARGE**

#### **3.9.1 Natural Recharge**

Groundwater receives its recharge primarily from rainfall. The percentage of groundwater recharge from rainfall varies, depending on the site conditions, from 2 to 20%, the average for the country being 10%. Surface water bodies like streams, canals, storage reservoirs and excess water applied to agricultural fields also contribute to GW recharge. Recharge from rainfall and surface water bodies take place when GW occurs under water table condition in unconfined aquifer. Such recharge is *in situ* in nature. Recharge to the confined aquifers can not take place *in situ* due to the presence of the overlying confining layer. Such recharge is actually

received from a far away location where the formation is exposed to the ground surface. Sometimes, over pumping of a confined aquifer may induce some recharge from the water table aquifer through leakage, depending upon the Transmissibility of the overlying confining layer.

### **3.9.2 Artificial Groundwater Recharge**

The practice of enhancing groundwater recharge over and above the natural recharge is commonly referred to as artificial recharge. Common methods of artificial recharge are water spreading method, induced recharge and injection method. Suitability of a particular method is based on the nature and geometry of the aquifer system, its Geohydrological parameters, quality of source water and proposed use of the groundwater.

Important considerations for source water to be used for artificial groundwater recharge are:

- Excess water should be available at site for recharge.
- Water should be made free from all suspended matters before use.
- Quality of the source water should be compatible with that of the existing water in the aquifer to be recharged.

#### **A. Water spreading method**

Excess water is diverted and made to spread to a large area for a long period thereby allowing more infiltration through natural process. It is usually achieved by spreading water in channels, recharge basins, ponds and pits.

#### **B. Induction method**

In this method, the natural conditions like the hydraulic gradient of the water table is manipulated to create extra storage space within an aquifer so as to induce rapid movement of infiltrating water. Bore wells or dug wells may be used in this method where water is filled into the wells to make a vertical water column to stand over the water table. The hydrostatic head of the water column allows water to enter the aquifer. Sometimes, excess storage space in an aquifer is created by



controlled pumping in a well to induce movements of target water from the vicinity to move into the target well. Induction method of recharging is used not only in taking advantage of the presence of a source of recharge nearby but also have been applied experimentally in drainage and saline water replacement projects.

### **C. Injection method**

In this method water is injected into the aquifer using some extra pressure. The extra pressure is commonly achieved by building a standing water column into the bore well from which the source water gradually enters the aquifer. As water is directly fed into the aquifer, injection method is suitable for recharging deep seated unconfined aquifers.

To bring the water table back to the weathered zone aquifer in hard rock areas, we need to build many site specific Artificial Groundwater Recharge Structures and monitor their effectiveness. In other older alluvium regions (Punjab, Haryana, Delhi etc.), Artificial Groundwater Recharge Structures which must have a pipe inserted down to the water table to directly deliver the source water into the water table. For effective Groundwater Recharge, the source water should necessarily be made silt free and its quality be compatible with that of the Groundwater. Else, we would increase Groundwater quality deterioration.

## **3.10 ESTIMATION OF RECHARGE**

It is customary to differentiate the phenomenon of recharge as the *monsoon recharge* and the *non-monsoon recharge*. While, the monsoon recharge is contributed mostly by the rainfall, the non-monsoon recharge is received from the existing surface water bodies like rivers, canals, tanks, excess water in agricultural fields etc. and from non-monsoon rainfall, if any.

### **3.10.1 Monsoon Recharge**

Monsoon recharge is computed by multiplying the seasonal fluctuation (F) in groundwater table with the corresponding surface area (A) and specific yield (S) of the aquifer. The amount of recharge is, therefore, given by:

$$Q = FAS$$

As withdrawal continues even during the period of recharge, the amount of monsoon withdrawal is to be added and recharge from any other surface water bodies are to be subtracted for obtaining the total quantity of monsoon recharge. Thus,

$$\text{Monsoon Recharge} = FAS + W_m - (R_c + R_t + R_i)$$

Where,

- F = Average pre-monsoon to post monsoon rise in water table, m
- A = Surface area under consideration (watershed/segment), sq.km
- S = Specific yield of aquifer (ranges normally between 0.02 - 0.2)
- $W_m$  = Monsoon groundwater withdrawal, Mcm
- $R_c$  = Recharge from canal seepage, Mcm
- $R_t$  = Recharge from tank seepage, Mcm
- $R_i$  = Recharge from excess irrigation water applied in cropped areas, Mcm

In hard rock areas where groundwater storage potential is limited, the aquifer usually gets saturated during the early monsoon period itself. Moreover, the reservoirs are in the process of filling up and the canals flows are yet to begin. Seepage from surface water bodies ,therefore, remains insignificant during the monsoon period. Large scale seepage from surface water bodies usually take place during the non-monsoon period. By neglecting, the contribution from surface water bodies to monsoon recharge, the above formula reduces to;

$$\text{Monsoon Recharge} = FAS + W_m$$

### **3.10.2 Non-monsoon Recharge**

Non-monsoon recharge is computed by using the following equation

$$\text{Non monsoon Recharge} = R_c + R_t + R_i + W_{nm}$$

Where,

Wnm = Non monsoon groundwater withdrawal, Mcm

### 3.10.3 Contribution from Other Sources

Guidelines for estimation of contribution of different surface water bodies to groundwater recharge was initially prepared by the Ministry of Agriculture in 1972 as mentioned below.

- Recharge due to seepage from unlined canal ( $R_c$ ) is taken as 15-20 ham/day/sq.km of wetted area of canal for the number of days of its flow.
- Average seepage from perennial surface water bodies ( $R_t$ ) is taken as 44-60 cm per year over the total water-spread area of the water body. In western region of the country, recharge rate from large surface water bodies are taken as 0.6 cu.m/hr per 100 ha of water-spread area.
- Return seepage from irrigated fields ( $R_i$ ) is taken as 40% of water delivered from the canal outlet of the field for paddy irrigation only.

### 3.11 ESTIMATION OF GROUNDWATER EXTRACTION

Annual (or seasonal) groundwater withdrawal from an area is estimated from the extent of the cropped area under groundwater irrigation. Alternately, this can also be estimated from the pumping details of the existing wells in the area.

#### A. *Based on cropped area*

Groundwater withdrawal from an area can be estimated fairly well, if the extent of total cropped area under irrigation from groundwater, the type of crops grown in these area, water requirement ( $\Delta$ ) of these crops and effective rainfall of the area are known. The estimation is based on the underlying assumption that if a certain type of crops have been grown in a certain area from groundwater, the water requirement to mature these crops is equal to the groundwater withdrawal minus the effective rainfall. Thus,

Withdrawal (ha-m) = Cropped area (ha) x Crop delta (m) - Effective rainfall (m)

## ***B. Based on pumping detail***

Groundwater withdrawal from an area can be estimated if the total number of pumps operating in the area, their average discharge rates and total pumping hours are known. Thus,

Withdrawal = Number of pumps x Average discharge rate x Total pumping hours

### **3.11.1 Categorization of Blocks**

Groundwater management in India follows estimation and categorizing of groundwater potential of each revenue Block or the Taluka. The State Groundwater Departments carry out survey to estimate net annual groundwater recharge and net annual groundwater withdrawal for each revenue Block. The Block is then categorised as Dark, Grey and White depending upon the difference between the net annual withdrawal and the net recoverable recharge as per the following scheme

- Dark: When annual withdrawal is greater than 85% of the net recoverable recharge.
- Grey: When annual withdrawal is between 65-85% of the net recoverable recharge.
- White: When annual withdrawal is less than 65% of the net recoverable recharge

There is no restriction in groundwater development activities in a revenue Block under White category. Activities related to groundwater development in Grey blocks are to be undertaken with sufficient caution and groundwater development through construction of new wells is to be altogether prevented in blocks under Dark category.

## **3.12 GRONDWATER RECHARGE STRUCTURES**

*In situ* GW recharge structures usually are constructed in hard rock areas with an unconfined aquifer. Most water harvesting structures double as GW recharge

structure if sufficient infiltration takes place from their bottom. It will therefore be useful to decide before hand whether the purpose of the structure is for storage of water or for recharging of GW. The design in such events are to be slightly different from each other.

### **3.12.1 Water harvesting structures for Groundwater Recharge**

The following criteria for construction of an artificial groundwater recharge structure are important.

- The structure should be reasonably close to the source water to be used for recharge.
- The quantity and quality of the source water should be of an acceptable level.
- The structure should be constructed such a way that it allows percolation of silt free water directly in to the aquifer.
- The rate of percolation through the structure should be adequate to justify its construction.
- The structure should preferably be constructed in areas where existing bore wells show a trend of falling water level.
- The beneficiary community are willing to take charge of the structure for regular maintenance.

Rainwater harvested and stored in tanks, pits, field ponds, contour trenches etc. in watersheds are known to contribute substantially in enhancing soil moisture regime in the vicinity in addition to contributing to groundwater recharge. It should however be remembered that when a surface water body is freshly dug, its contribution groundwater recharge is relatively high commensurate to its site conditions. Over the years, as the water body starts depositing silt at its bottom sealing most of the immediate pore spaces, quantity of recharge reduces drastically. It is therefore a good practice to de-silt the surface water bodies from time to time for restoring its storage capacity as well as its recharge potential

### **3.12.2 Percolation Tank**

These are small water storage structures constructed by raising earthen bunds

across large natural depressions or small valleys. Site selected for these tanks should be such that, a large part of the stored water percolates down to join to the groundwater reservoir.

In order to facilitate percolation, sufficient excavation of the tank bed at the time of its construction as well as removal of silt from its bottom in the subsequent years as a part of its maintenance are necessary. Objective of a percolation tank is to facilitate infiltration of as much stored water as possible into the groundwater reservoir. While large percolation tanks constructed at favourable sites are known to recharge wells as far as 2-3 km downstream, smaller tanks (< 0.5 ha-m) may not as such contribute much to groundwater recharge particularly when the water table is rather deep. Although, the recharge from percolation tanks is basically a localised phenomenon, but these have been found quite effective in recharging a small cluster of wells in the downstream and in enhancing the soil moisture regime in the vicinity benefiting crop growth.

### **3.12.3 Check Dam**

Check dams are masonry over flow weirs constructed across seasonal streams. A check dam as such has a relatively limited storage capacity. But sufficient water is still stored in its upstream side to allow pumping of water for irrigation. Water can also be diverted to nearby fields through small field channels. The other purpose of check dam is to recharge the groundwater storage reviving dug wells in the downstream side. To what extent a check dam will contribute to groundwater recharge will depend upon the natural recharge potential of the stream in which the check dam has been constructed. Check dams are most suitable for construction on seasonal streams or streams having a small base flow for most part of the year. These can also be constructed in large flowing streams as well excepts that its construction becomes as much difficult. Construction of check dams require certain degree of technical expertise (Chapter 6).

### **3.12.4 Sub-Surface Barriers**

These are sub-surface dykes across seasonal streams or other depressions constructed underground, usually extending down to the bed rock. The bed is first excavated to the desired depth. The dyke is constructed with puddled clay or with

stone masonry wall. Polythene sheets are also spread in the upstream side to render the dyke completely impervious. Site for sub-surface barrier should be such that sufficient lateral percolation also takes place. Sub-surface barriers are more useful in generating a base flow in a seasonal stream to its upstream side by tapping the sub-surface flow. Wells in the stream bed or close to the banks get augmented yield. A check dam, which is constructed right from the bed rock to a few metre height above the bed level is in fact a combination of both a surface and a sub-surface barrier.

### 3.12.5 Recharge Wells

Recharge wells are opposite to pumping wells. Additional water is diverted into a recharge well from naturally available source of water. The well is filled up with clean, filtered water and a water column is allowed to build up. Water percolates into the aquifer due to the hydrostatic head of the standing water column in the well. A recharge well could be designed like a dug well to recharge shallow unconfined aquifer or like a dug cum bore well to recharge a deep unconfined aquifer (Fig. 3.7).

While pumping wells tend to be *self cleaning*, recharge wells tend to be *self sealing* due to clogging by silt, air binding, bacterial actions and chemical reactions. For effective functioning, the water used for Recharge water must be free from silt and other suspended materials. A dug well, once used as a recharge well, is not likely to remain useful for reverting it back to a production well in the future unless deepened and cleaned thoroughly. Existing dug wells yielding reasonable quantity of water should preferably not be used as a recharge well.

Recharge tube wells are more effective where water level is very deep. A typical recharge tube well designed by VRTI (Raju, 1995) is presented in Figure 3.6. A 30 cm bore is first drilled through the formation that is to be recharged. A tube well is completed by lowering 20 cm casing pipes with slots placed against the formation to be recharged. The tube well is developed properly after placing gravel in the annular space between the casing and the bore. A 6 m x 6 m x 6 m pit is then dug out at the surface around the tube well. The upper part (6 m) of the exposed casing pipe is then cut off and replaced with a slotted pipe of same diameter. Coir rope is wound around the slotted pipe to convert the same into a packed filter to prevent

entry of silts into the well. The pit is then filled up with graded filter materials like cobbles, pebbles, gravels etc. Such recharge tube wells are constructed either directly into a seasonal stream bed or connected with a feeder channel to supply sufficient water for recharge. The same design has also been found to be the most effective for groundwater recharging using water from roof tops (Roof Water Harvesting) in urban area.

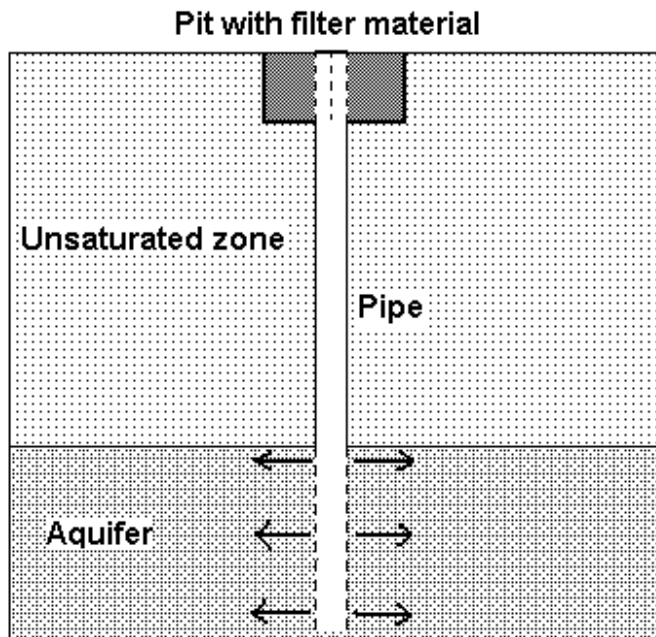

### 3.6 A thematic arrangement of Groundwater Recharge Structure

A series of recharge wells along coastal areas have been found to be effective barrier against sea water ingress. In fact, unlined irrigation canals in many areas serve as very effective GW recharge structure.

### 3.13 LIMITATIONS IN ARTIFICIAL RECHARGE

The other factors that affect GW recharge are:

#### 3.13.1 Depth of water table



As summer season approaches, the depth of water table gradually recedes below. This results in the development of a dry zone known as intermediate zone between the soil water groundwater. In areas with very deep water table, the thickness of this intermediate zone may become too large. In order to commence GW recharge in such areas, the rain water has to first saturate the entire intermediate zone before the gravitational water start flowing down

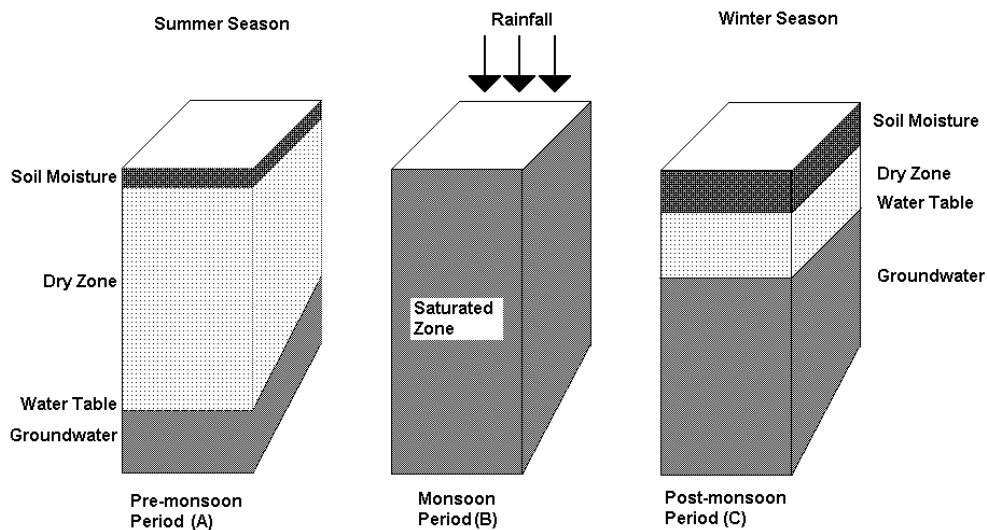

### 3.7 Schematic representation of Groundwater recharge process

And begin to contribute in building up the water table. It is, therefore, possible that a large part of infiltration from rainfall particularly in a low rainfall year, may get dispersed within the intermediate zone thus contributing very little to groundwater recharge.

The situation described above may be true for an area like Rajasthan (and adjoining Haryana) where a larger part of the area is underlain by unconsolidated formation, the water level is fairly deep and rainfall is low. The effect may be cited better by considering an earth block of 1 ha surface area, in which the depth of water table is say, 21 m and thickness of the soil water zone is 1 m (Fig.3.7). Let the rainfall of the area is 750 mm and the porosity of the formation is 20%.

The volume of the block comprising of only the intermediate zone is  $100\text{ m} \times 100\text{ m} \times 20\text{ m} = 200000$  cubic metre. The volume of the pore space within this block is  $200000 \times 0.2 = 40000$  cubic metre. The total volume of rainfall over this block is

$100 \text{ m} \times 100 \text{ m} \times 0.75 = 7500 \text{ cubic metre.}$

It is obvious that even if the entire rain water percolates down, the total volume of rain water (7500 cubic metre) is far less than the volume of pore space available in the formation (40000 cubic metre) that needs to be saturated before recharge begins. Hence, areas with deep water table and low rainfall receive much less recharge than believed. In fact in such areas, the groundwater recharge is likely to become very negligible and may altogether stop, once the water table is lowered below a critical depth. Such situation, however, does not arise, in hard rock formations, where water table fluctuates in seasonal cycle and some water always join the groundwater reservoir directly through the fractures.

From water use point of view, an irrigation tank and a percolation tank has the conflicting priorities. It is therefore, important to decide before hand weather the tank to be constructed is to function as a storage tank or as a percolation tank. The site then should be selected accordingly. While an irrigation tank should have sufficient cultivable lands in the vicinity for direct use of the stored water, a percolation tank should not only ensure sufficient infiltration but also should have existing wells in the vicinity to take advantage of the recharge. The nature of the geological formation plays the most important role in deciding the effectiveness of a percolation tank. Recharge from a percolation tank may be insignificant at a site where the formation has low permeability, down-stream side has high slope and the water table is deep (Fig. 3.6).

### **3.13.2 Extent of Seepage**

Most surface water storage structures, weather intended or not, induce some infiltration in a localised scale. The degree of infiltration will depend upon the permeability of the bed sediments, permeability of the underlying formations and the spread, duration and depth of stored water. In the initial years of their construction, most storage tanks behave as a composite tank allowing sufficient infiltration. Over the years, the infiltration reduces and become quite insignificant due to the deposition of bed sediments (siltation).

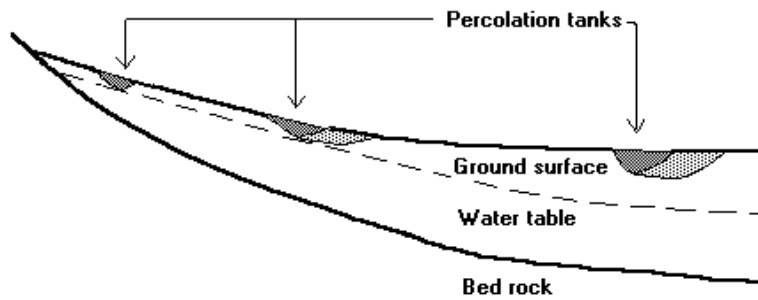

**Fig. 3.6 Effects of location on percolation tanks in recharging groundwater**

In order to maintain their effectiveness, percolation tanks, therefore, require periodical removal of its bed sediments. Infiltration loss from a storage reservoir is considered a loss of water. The infiltrated water, however, have more sustainable use in crop production, as groundwater and soil moisture, than direct use of the stored water.

- The design of the recharge structure should be appropriate as per the site conditions.
- Functioning of the recharge structure is to be sustained through regular maintenance.

### **3.13.3 Use of old dug wells for recharge**

All abandoned dug wells are not necessarily suitable for use as a recharge structure. Millions of dug wells in the country which at one time were yielding has gone completely dry. This because even the post-monsoon water table in the area does not rise enough to reach the wells. An abandoned dry dug well is just as good as a deep pit. When water from an external source is stored in a dry dug well, water starts percolating in to the formation and can contributes to recharge depending upon the permeability of the formation and depth to the water table. However, certain precautions are necessary while using an abandoned dug well as a recharge structure. First of all, the abandoned dug well should be clean enough i.e free from any dumping of undesirable materials like plastic, tree leaves, soil, bricks and silt.

Secondly, the water allowed to be stored in the dry well from an external source for recharge should be as silt-free as far as possible. If considerable amount of silt

enters the well, the pore space of the formation in the immediate vicinity of the bottom and side of the well would eventually get clogged up preventing any meaningful seepage. It is quite common to find that where dug wells are being used for GW recharge, surface water run off laden with full silt load is allowed to flow directly in to the dug wells through some makeshift drain or channel, sometimes with a perfunctory provision for a settlement pit. Needless to mention, the ability of these abandoned dug wells to recharge would be reduced to naught rather soon due to siltation unless cleaned thoroughly at least once a year.

GR recharge through abandoned dug wells is meaningful in areas where there are other wells to tap the benefit of the additional recharge i.e sacrifice the shallow dug wells to feed the other deeper wells. Finally, it should be remembered that if the dug well (dry pit) is of shallow depth and the water table is at considerable depth, there would be no recharge. The percolated water will eventually get lost within the unsaturated zone without reaching groundwater (saturated zone).

It may also be remembered that only a dry and abandoned dug wells should be used for GW recharging. If a perfectly or seasonally functioning dug well is used, then deposit of silt will prevent both the entry in to or percolation from the well *vis a vis* the formation.

## ***4.0 Soil and Land Capability Class***

---

### **4.1 IMPORTANCE OF SOIL**

Like human beings, plants too need the right kind and amount of food for their growth and development. In addition to light, air, heat and water, plants require nutrients to synthesize their food. Soil is the storehouse for plant nutrients which not only support plant life but also are the single most important factor in controlling productivity of crops. Soil in conjunction with water is the foundation of all life system, on earth. Agricultural lands lose their productivity very rapidly when they are subject to loss of top soil due to erosion. Qualitative deterioration of lands takes place due to poor management of its soil. Proper management of land (soil) therefore, assumes great importance, especially in a country like India where agriculture is the main occupation.

The various ways by which soil erosion can affect crop growth include:

- Reduction in soil nutrients.
- Reduction in soil moisture-holding capacity due to loss of soil depth, soil organic matter and clay contents.
- Reduction in available soil water due to increase in run-off, surface crusting, greater bulk density of soil.
- Reduction in rooting depth due to decreased top-soil depth.
- Reduction in soil microbes involved in nutrient recycling and soil aeration.
- Reduction in seed germination.
- Increase in the washing away of seeds and fertilizer from soil surface.
- Increase in the time spent on farming operations.
- Variability in soil fertility can cause within-field variation in crop maturity resulting in harvest loss.

The above effects on crop growth are iterative and cumulative in nature. The extent to which erosion actually reduces yield is also determined by a number of other

factors. Shallow-rooting crops tend to be more sensitive to the effects of erosion on yield. Crop management systems can, however, compensate for the effects of erosion on yields through increased fertilizer application, adoption of different cultivation practices and use of irrigation water.

## **4.2 FORMATION OF SOIL**

### **4.2.1 In Situ Formation**

Soil occurs as the uppermost layer of the earth's surface. Factors that affect formation of soil are climate, vegetation, topography and composition of the parent rock from which they are derived. Formation of soil at its place of origin (*in situ*) takes place by gradual breaking down of the parent rock into smaller particles through the process of weathering. The weathered rocks in course of time get enriched through the inclusion of organic matter to form common soil. The process of soil formation is hence extremely slow.

### **4.2.2 Deposited Soil**

Deposition or redistribution of soil particles from one place to another also gives rise to the formation of soil of secondary origin. Thus, alluvial soil is formed when the sediments carried away by the rivers are deposited. Similarly, fine soil particles blown away by wind, deposited later at places where the wind is obstructed, give rise to the formation of a typically fine grained soil known as *loess*. A typical soil deposited at the foot hill areas due to combined wind and water actions is known as *Piedmont deposit*.

### **4.2.3 Chemical Decomposition**

Soil is also formed rapidly at locations where chemical decomposition plays a major role. Silica ( $\text{SiO}_2$ ) which forms stable compound with most rocks gets unstable (free) due to chemical reactions. When a large quantity of this free silica is washed away by combined chemical and water action called *leaching*, the top part of the country rock becomes soft and is rapidly converted into soil. Laterite soil, which is red in colour, is formed under this process.

### 4.3 COMPOSITION OF SOIL

Soil is a composite mixture of mineral matter, organic matter, water and air. The mineral matter of the soil consists of particles of varying size, namely sand, silt and clay. The chemical composition of the soil particles depend upon the parent rock from which they have been derived. Since minerals like *quartz*, *feldspar*, *hornblend* and *mica* are the common constituents of many rocks, elements like silica, aluminium, potassium, sodium and calcium, which are derived from these minerals are available in large quantities in most soils.

Soil gets its supply of organic matter from the decomposed residues of dead plants and animals. The numerous micro-organisms present in the soil help in the process of decomposition of organic matter. An important product of the thoroughly decayed organic matter is *humus*. This grey-coloured semi-liquid sticky material, which is relatively more resistant to microbial decomposition, adheres around the clay particles. Humus, in conjunction with clay, forms minute particles, round in shape (spheroids), which increase the porosity of soil. The pore space of soil normally remains filled with water and air in varying proportions. The composition of a mature soil that provides a favourable condition for plant growth is mineral matter (45%), organic matter (5%), soil air (25%) and soil water (25%).

### 4.4 PHYSICAL PROPERTIES OF SOIL

From the crop production point of view, the important physical properties of soil are its texture, structure, porosity, permeability, density, colour and tendency of colloid formation. These, in fact have relatively greater relevance to soil erosion and crop production than its chemical properties.

#### 4.4.1 Soil Texture

Soil particles, based on their size, are classified into three major groups, namely sand, silt and clay. The *texture* of a soil is determined by the proportion (percentage distribution) of different grain sizes, i.e. sand, silt and clay, present in the soil.

Thus, if a soil is comprised predominantly of sand, the texture of the soil is *sandy*

(light soil). Conversely, if the percentage of clay in a soil is considerably high, the texture of the soil is *clayey* (heavy soil). The term *loam* is used when a soil is represented by a fair proportion of soil particles from all these three distinct size groups. In field condition, the particles, specially the smaller ones, do not necessarily exist separately but are bound together to form aggregates.

The size range of these soil-separates, are presented below:

Soil separates	Texture	Size range, mm
Sand	Coarse	Above 0.02
Silt	Medium	0.02 - 0.002
Clay	Fine	Below 0.002

**Table 4.1 Differentiation of soil particles in major groups**

Soil texture is determined in the laboratory by mechanical analysis of soil samples. A fixed quantity (100 gr) of dry soil sample is sieved through a series of pans having wire mesh of decreasing sizes. The particles retained in each pan are collected and their weights are taken. The percentage weight retained in each pan are presented in a graphical form to describe the soil Texture (Figure 4.1). It is, however, possible to make a rough estimation of soil texture in the field itself. Experienced soil scientists are capable of ascertaining soil texture class by studying the particle sizes with a hand lens and also by general feel of the soil.

Since the moisture-holding capacity of a soil is greatly influenced by its texture, knowledge of soil texture has great importance in irrigation practices. Coarse sandy soil has large pore space permitting free movement of air, water and roots but has a low water-holding capacity. Water tends to move below the root zone much faster in such soils. Clayey soil has narrow pore space and has higher water-holding capacity. Water is held in clay soil for a much longer period. Soil texture also influences the selection of crops. For example, clay soil (*matiar*) is considered good for paddy, clay loam (*domat*) for wheat, silt loam (*parwa*) for maize and loam or sandy loam (*bhur*) is considered suitable for potato and other root crops.

Another well accepted method is to take a table-spoonful of soil and moisten it till it starts sticking to the fingers. Assessment of texture is made by the way the soil



can be rolled into different shapes, as set out in Table 4.2.

<b>Feel</b>	<b>Ball formation</b>	<b>Ribbon formation</b>	<b>Assessment</b>
Very smooth	Hard ball when dry	Can be rolled into more than 2.5 cm long ribbon	Fine, Clayey
Smooth	Moderately hard ball	2.5 cm long ribbon	Moderate fine, Clay Loam
Floury	Firm ball with cracks	No ribbon formation	Medium, Loam
Gritty	Will shape but not in round hard ball	No ribbon formation	Coarse, Sandy Loam
Very gritty	No ball formation	No ribbon formation	Coarse, Sandy

**Table 4.2 Assessment of soil moisture content by feel method**

#### **4.4.2 Soil Structure**

Soil particles normally remain arranged in a definite manner (structure). Soil structure is, therefore, identified by an examination of the natural arrangements of the soil particles in which they occur. Accordingly, soil structure is classified as *granular, columnar, platy, prismatic, blocky* etc. The structural arrangements of the particles also give rise to the general shape of a naturally occurring undisturbed soil.

The amount of pore space available in a soil of a given texture depends upon its structure. Round soil particles arranged in a columnar structure give the largest pore space within a soil. Soil structure is also influenced by the presence of organic matter and various cations (Ca, Mg, Na etc.). The amount of air and moisture that could be held by a soil is decided by its structure. Soil structure, therefore, has adequate bearing on crop production. However, when a soil is puddled, its natural structure gets disturbed. Puddle soil has minimum pore space and often offers unfavourable conditions for most crops, except paddy.

### 4.4.3 Soil Porosity

*Porosity* is the measure of pore space within a soil. The porosity of a given amount (volume) of soil is given by the ratio of the pore volume (v) to the soil volume (V). This ratio, which is a fraction, is normally expressed in percentage after multiplying it by 100. Thus,

$$\text{Porosity (\%)} = (v/V) \times 100$$

If a soil is said to have 20% porosity, it means that if 100 cc of the soil is considered, the volume of pore space within it will be 20 cc. When water comes in contact with soil, the pores start getting filled up till the soil is saturated. However, when a fully saturated soil is allowed to drain under normal gravitational force, a certain amount of water, known as *specific yield*, drains out of the soil, the balance remains held up within the pore space due to capillary force. This water which does not drain out from the soil by force of gravity is known as the *specific retention* of the soil. This is the water which is available to plants for consumptions.

The porosity of a soil depends directly upon the shape, size and arrangement (sorting) of the soil particles. Soils with round shaped, well sorted particles will have highest porosity. Presence of other cementing material in the soil will indirectly influence (reduce) the porosity. Values of soil porosity may range from 5-10% for a compact puddle soil to as high as 30-40% for a well sorted clay. It should be noted that porosity need not necessarily increase as the size of the soil particles increases. In fact, well sorted clay has higher porosity than most sands. Clay, however, has much less permeability than sand.

### 4.4.4 Soil Permeability

*Permeability* is the measure of the ease with which water moves through a porous medium. Following Darcy's law, the permeability of soil is measured by its *coefficient of permeability*, k, and is expressed in cm/hr or m/day. Knowledge of soil permeability and also that of the underlying formation is useful for ascertaining movements of water through soil. Permeability of soil samples is measured in the laboratory by using a *permeameter*.

Because of change in compactness, the permeability of a soil sample measured in the laboratory may differ from that of the same soil occurring under its natural condition. In order to reduce this difference, laboratory permeability tests should be conducted on specially collected undisturbed soil samples. Indication of field permeability is obtained by conducting in situ infiltration tests using an *infiltrometer*. Soil permeability up to a rate of 1.3- 20.0 mm/hr is considered as *slow*, 20-50 mm/hr as *moderate*, 50-250 mm/hr as *rapid* and greater than 250 mm/hr as *very rapid*.

#### **4.4.5 Soil Density**

Soil density is the weight of a unit volume of soil and is expressed in gr/cc. Since, soil is comprised of soil particles and soil air, soil density is measured either as its *bulk density* or as its *particle density*. Soil density measured together with the existing air and water is its bulk density and that measured without the pore space, i.e of the grains alone, is particle density. The difference between these two densities is useful in estimating the volume of pore space and hence the porosity. For example, say, 1 cc of soil with air in its pore spaces is found to weigh 1.5 g (bulk density) while the actual density of the constituent mineral say quartz (particle density) is 2.0. The extent of pore space is then given by:

$$\text{Pore space} = 1 - (1.5/2.0) = 0.25 \text{ cc}$$

$$\text{Porosity} = (0.25/1) \times 100 = 25\%$$

#### **4.4.6 Soil Temperature**

Soil temperature has great relevance for germination of seed and plant growth. Too high (above 50° C) or too low (below 1°C) temperatures are detrimental to crop growth. Soil generally gets its heat from the sun. The capacity of a soil to absorb heat from sun depends upon its colour, texture, structure, composition (specific heat property) and the direction of slope.

Dark or black coloured soil will absorb more heat than light coloured soil. A coarse soil can absorb more heat than fine textured soil. A granular soil has more heat absorbing capacity than a compact soil. Again, a southerly sloping land in the

northern hemisphere would face the sun for longer hours and hence absorb more heat than a northerly sloping land.

Soil heat may also be generated by chemical reactions within the soil and in some special situations from the interior of the earth. Microbial activities in the soil also generate some heat. Though the temperature of soil on its surface may fluctuate quite widely, the temperature a few cm below the surface remains more or less uniform, thus protecting plants from the hazards of fluctuation in ambient temperature.

#### **4.4.7 Soil Colour**

The colour of a soil gives an indication of its origin, its dominant chemical composition and the extent of organic matter present in it. Black colour of a soil may originate from the colour of the parent rock rich in basic minerals, e.g black cotton soil derived from basalt. Soils rich in organic matter will also tend to have a dark colour. Presence of large quantities of iron oxide imparts a reddish colour, e.g laterite soil. Soil rich in sodium or other salts tends to gather deposits of white powder on its surface.

#### **4.4.8 Colloid Formation**

When a small amount of dry soil is poured into a glass of water, it is found that a small fraction of the soil gets dissolved into the water and the heavier particles gradually settle at the bottom. A certain amount of soil particles, however, neither get dissolved nor settle but remains suspended, giving the water a muddy colour. These suspended particles which remain in water in colloidal form are held in place by molecular attraction and do not settle under normal conditions. Soils with large amounts of fine particles are prone to large-scale colloid formation. Colloid formation by a soil has great practical significance since it is one of the important factors which influence its susceptibility to water borne erosion and soil salinity. Prevention of soil loss in colloidal form, even from a well protected field, is a difficult task.

### **4.5 SOIL REACTIONS**

Amongst the chemical properties of soil, soil reactions deserve special attention from crop production point of view. Evaluation of soil reactions gives a useful insight into the presence of reactable salts in the soil. Common soil reactions studied for the purpose of crop production are pH and total dissolved solids (TDS).

#### **4.5.1 Total Dissolved Solids**

Total dissolved solids (TDS) also referred as Total Soluble salts (TSS) present in a soil in fact control the chemical reactions of a soil. TDS is estimated by measuring the electrical conductivity (EC) of the soil saturates. A certain quantity of soil sample is first mixed with a proportional quantity of water (1:2) for a given period so that the salts present in the soil are dissolved into the water. The water (soil extract) is then filtered and used for the measurements of EC and pH.

Electrical conductivity (EC) is measured in *micro or milli mho per cm* at 25 °C by using conductivity meter. The *milli mho/cm* is also referred to as *desisiemens/cm* (ds/cm). EC value obtained at room temperature is normally converted at 25 ° C by using a calibration chart. TDS value is then obtained by multiplying EC value with a factor of proportionality which is equal to 0.648.

#### **4.5.2 Soil pH**

The degree of ionization (hydrogen ion concentration) measured on logarithmic scale is pH. The value of soil pH gives an indication of the degree of its acidity or alkalinity. Soil pH is measured in a scale ranging from 0-14. A neutral soil has a pH value equal to 7. Soils having pH value less than 7 are acidic and those with a pH value above 7 are alkaline.

Presence of negative ions like hydrogen, sulphate, chlorides etc. and also cations like iron (Fe) reduce the pH of a soil. Presence of too much of sodium, particularly as carbonate, compared to calcium and magnesium salts, increase soil pH, making the soil alkaline. Soil extract is collected first and pH is then measured by using litmus paper, colour comparator, titration, pH meter etc. Most field soil testing kits are equipped to provide a rough estimate of soil pH, soil TDS and soil nutrient status. Soil reaction classes and their effect on crops are presented in Table 4.3.

pH value	Remarks	EC value, ds/cm	Remarks
Below 6.0	Acidic	Below 1.0	Normal
6.0 - 8.5	Normal	1.0 - 2.0	Critical for germination
8.5 - 9.0	Slightly alkaline	2.0 - 4.0	Critical for growth
Above 9.0	Alkaline	Above 4.0	Injurious to most crops

**Table 4.3 Soil status based on chemical reactions**

## **4.6 SOIL SALINITY**

### **4.6.1 Acid Soils**

A neutral soil can gradually turn to acid soil if the alkali portion is gradually washed away thus enriching the soil with acidic salts. Presence of excess hydrogen, iron and aluminium ions make a soil acidic. Certain rocks, e.g granite, are naturally acidic and soils derived from these rocks would be acidic. Soil may also acquire acidity in an area rich with coniferous trees whose foliage generally contain less alkaline matter. Excess use of water (submergence) accompanied by continuous use of acid- forming fertilizers (ammonium sulphate, ammonium chloride) may lead to a reduction of soil pH and hence an increase in acidity.

Acid soil not only has a toxic effect on plants but also starves the plants by making some fertilizers like phosphate insoluble in water and also by reducing the supply of calcium from the soil. Reclamation of acid soils is done by applying powdered limestone ( $\text{CaCO}_3$ ) into the soil. The soil should be sufficiently moist at the time of application of lime which should be spread uniformly and mixed well with the soil. The amount of lime to be applied will depend upon the degree of acidity (soil pH) and also the texture of the soil.

### **4.6.2 Alkaline Soils**

Alkaline soil is formed when an appreciable proportion of the exchangeable calcium ion is replaced particularly by sodium in poorly drained soil over a long

period of time through a process known as *base exchange*. Some of the sodium ions react with carbonate and bicarbonate anions and sufficient sodium carbonate is formed in the soil solution, particularly under waterlogged conditions. The pH of alkaline soil is generally greater than 8.5 but the electrical conductivity (EC) is less than 4 ds/cm. As a result of base exchange, permeable soil becomes sticky, which on drying turns hard (kankar pan) rendering ploughing and drainage of soil difficult. The amount of organic matter and micro-organisms also is reduced to an unfavourable level. Sodium becomes toxic to the plants due to its excessive solubility.

Alkali soils, particularly the sodium dominated *usarsoils* are generally reclaimed by applying gypsum which is rich in exchangeable calcium, followed by application of organic matter. Such reclamation process may require 3 to 5 years of sustained efforts to show results, depending upon the pH of the soil and method of reclamation being applied.

### **4.6.3 Other Toxicity**

Ions like boron in excess quantity have an adverse effect on crops. For some crops excess chloride, sodium bicarbonate and sulphate could also be harmful. Sulphide as such is not damaging to crops but it has a corrosive effect on the cement concrete pipes used for irrigation. Toxicity of the soil is also developed due to the application of irrigation water containing excess of salts or other toxic ions. The Indian Saline Soil Research Institute (ISSRI), Karnal, has developed various field techniques for reclamation of problem soils.

## **4.7 PLANT NUTRIENTS**

Analyses of plant tissues have revealed that nearly 40 elements are normally present in a plant body. Out of these, however, only 17 have been identified as essential nutrients. Amongst these, hydrogen and oxygen are taken by plants entirely from water and carbon from air. The absorbed oxygen helps in producing CO<sub>2</sub> in the root zone, which should be allowed to escape. Other nutrients are derived by plants from soil. Plants require nitrogen, potassium and phosphorous in large quantities. Calcium, magnesium, iron and sulphur are needed in moderate quantities. The rest of the nutrients are required only in a very minute quantity or

in traces. Presence of these trace nutrients in a large quantity in the soil may create a toxic effect on the plants, e.g boron, sodium, cobalt etc.

A large part of air is nitrogen but plants cannot absorb it from air and hence it is taken from the soil. The residues of dead plants eventually contain most plant nutrients which had been consumed earlier from the soil itself. When these residues come in contact with the soil, the soil bacteria slowly decompose them into finer particles and make a part of the constituent nutrients water soluble. Hence all the required food items can be supplied to soil through application of plant residues and other biomass.

Some bacteria also help in supplying nitrogen to plants particularly when the soil is poor in nitrogen. *Azotobacter* and *Radicicola* are the two representatives of these types of bacteria. These bacteria multiply within the nodules formed in the roots of most leguminous plants (plants bearing pods, eg. *Dal*, *chana*, *subabul*), and absorb nitrogen from the air. When these bacteria die, the nitrogen thus accumulated becomes soluble in water and remains in the soil for use by plants.

Another important compound useful for plant growth is soil *humus* which is present in soil in varying degree. It is derived from the decomposition of organic matter and performs numerous functions. Physically it modifies soil colour, texture, structure and water-holding capacity. It improves aeration and drainage by making the soil more porous. Chemically it serves as a food nutrient, maintains soil pH and influences solubility of certain soil minerals. The basic components of humus are carbohydrates, amino acids, fat, waxes and lignin. Humus content in soil depends primarily on the amount and nature of organic matter returned to the soil and to its subsequent decomposition. The rate of decomposition depends upon climate, presence of soil bacteria and the C:N ratio of the biomass. Under prolonged stable environment, humus content in some soils remains at quite a constant level.

#### **4.7 SOIL FERTILITY**

A normal soil loses its fertility due to consumption of nutrients by crops, leaching of elements due to excessive irrigation, loss of nutrients in gaseous forms and soil erosion. Basic steps for preventing loss of soil fertility are maintaining the soil



thickness by preventing erosion, providing proper drainage for aeration, preventing salt accumulation and supplying organic manure, inorganic fertilizer and micro nutrients.

#### **4.7.1 Organic Manure**

Organic manure includes both fresh and decomposed products of all plants, animals and microbes. Organic manure helps in developing the granular structure of the soil which provides enough room for both air and water. Soil with organic matter develops resistance to erosion. It gives soil a capacity to maintain its temperature. Organic manure, especially green manure, can correct acidity or alkalinity of soil and counteract the effect of heavy metal. It also provides food to micro-organisms which in turn prepare food for the plants. The common organic manures are described below:

##### **A. *Farm yard manure (FYM)***

This is the decomposed product of dung and urine mixed with varying amounts of straw and other litters of farm animals. A well-decomposed farmyard manure normally contains 0.5% nitrogen, 0.2% phosphorous and 0.5% potassium by weight. Cattle urine is a rich source of plant nutrients.

##### **B. *Compost***

In order to destroy the pathogens and suppress disagreeable odour, organic wastes are decomposed prior to their application to the field. The process of pre-treatment of all organic matter is known as *composting*. The organic matters is dumped into a pit and, in order to hasten the process of decomposition, some animal urine, animal dung or fertilizers are added. Livestock and human waste, crop residues, urban and rural wastes (sewage sludge, market wastes etc.), agro-industrial byproducts and wastes, slaughter-house waste, aquatic plants, forest litters, tank silt, fish wastes, marine algae, sea-weeds etc. are the commonly available organic matters useful for composting.

##### **A. *Nitrogen***

Nitrogen is taken up by plants from the fertilizer in the form of nitrate ( $\text{NO}_3$ ) and ammonia ( $\text{NH}_3$ ). The types of nitrogenous fertilizers commonly used are :

- Nitrate fertilizer (Sodium Nitrate, Calcium Nitrate, Potassium Nitrate)
- Ammoniacal fertilizer (Ammonium Sulphate, Ammonium Chloride)
- Ammoniacal Nitrate fertilizer (Ammonium Nitrate)
- Amide fertilizer (Urea, Calcium Cyanamide)

Nitrogen compounds constitute 1-4% of the dry matter of a plant. Nitrogen is also required for the formation of proteins and chlorophyll. High doses of nitrogen may facilitate more vegetative growth at the cost of grain formation. Excessive nitrogenous fertilizer applied to the soil can even scorch a crop. Usually 50-60 % nitrogen available in soil is taken up by crops and some (5%) is lost by leaching per year. Since new crops exploit only a fraction of top soil, nitrogen occurring in the deeper part of the soil will not be available to them. A considerable amount of nitrogen is also lost by evaporation and leaching. In order to minimize these losses, nitrogenous fertilizer should be applied judiciously.

### ***B. Phosphorous***

Some 0.1 - 0.4 of dry matter in a plant is phosphorous. It is an important constituent of the living cells and is useful in the formation of roots, litters, seeds and fruits. Phosphorous is essential to photosynthesis as it transfers energy within a plant. It also helps in proper absorption of nitrogen and facilitates early maturing of crops. Plants normally do not absorb more than 15-20% of the phosphorous fertilizer added to the soil. Phosphorous occurs in inorganic form as absorbed anions on soil colloids and partly in humus. Phosphorous from both these sources is released slowly to maintain a very low equilibrium.

### ***C. Potassium***

Potassium forms some 1-4% of the dry matter of a plant. It plays an important role in the synthesis of carbohydrates and proteins in the plant and the transfer of these from one part of the plant to another. It regulates water flow within the plant and imparts vigour and resistance to plants against attacks of pests. It occurs in exchangeable form in soil solution.

### 4.7.3 Composite Fertilizer

#### A. *NPK complex*

However, due to the inconvenience involved and lack of interest in getting soil nutrient status properly assessed farmers, too frequently, prefer to use NPK complex fertilizer in which all the three nutrients are present in certain proportions. NPK fertilizers are marketed in different grades. A grade of 17-32-16 means the fertilizer contains 17% nitrogen ( $\text{NO}_3$ ), 32% phosphate ( $\text{P}_2\text{O}_5$ ) and 16% potassium ( $\text{K}_2\text{O}$ ). The remaining 35% is made up of filler materials like gypsum, limestone etc. It is, however, advisable to get soil samples regularly tested in the laboratory for ascertaining the NPK status and other nutrient contents of the soil. Agriculture department, in every state have district level soil testing laboratories for analysing soil samples for farmers. Table 4.4 is useful in assessing the NPK requirement of the soil.

<b>Nutrients</b>	<b>Low, kg/ha</b>	<b>Medium, kg/ha</b>	<b>High, kg/ha</b>
Available Nitrogen (N)	< 280	280 - 560	> 560
Available Phosphorous (P)	< 10	10 - 25	> 25
Available Potassium (K)	< 110	110 - 280	> 280

**Table 4.4 Nutrient status of soil**

#### B. *Micro nutrients*

The secondary nutrients like sulphur, calcium, magnesium, boron, copper, iron, manganese, molybdenum, zinc, chlorine etc. are available in the market as specific products containing a wide range of primary and secondary nutrients. These fertilizers are known as micro-nutrients.

## 4.8 CLASSIFICATION OF SOIL

Depending upon the criteria used, soil can be classified into a number of groups.

Thus classification of soil by age (recent soil, old soil), occurrence (forest soil, marsh soil), geological origin (mountain soil, alluvial soil), colour (red soil, black soil), structure (granular, columnar), texture (sandy soil, clayey soil), chemical reaction (acid soil, alkali soil), fertility (fertile soil, unfertile soil) etc. are common. According to international classification (soil taxonomy) practice, soil is classified in order, sub-order, great group, sub-group, family and series in a hierarchal fashion. This classification needs identifying each series or mapping units and is used extensively in detailed soil mapping.

#### **4.8.1 Major Soil Groups in India**

For the purpose of crop production a simpler classification is always helpful to a common farmer. Thus soil classification based on occurrence serves the purpose.

##### *Alluvial soils*

Alluvial soils constitute by far, the largest and most important soil group supporting agriculture in India. The numerous tributaries of the Yamuna, the Ganga, the Brahmaputra and other river systems have contributed to the formation of major tracts of alluvial soil in India. Alluvial soils are also formed in the delta and coastal regions. Alluvial soils in general are poor in phosphorous, nitrogen and organic matter.

##### *Black soils*

The typical black coloured soil found in the Deccan area belongs to this group. Black soils are found in Maharashtra, western Madhya Pradesh and in parts of Andhra Pradesh, Gujarat and Tamil Nadu. These are formed by weathering of basic rock like basalt. They are fertile, argillaceous, fine-grained, containing a high proportion of calcium and magnesium carbonates. They are poor in phosphorous, nitrogen and organic matter.

##### *Red soils*

These are found in Tamil Nadu, Karnataka, Goa, south-eastern Maharashtra, eastern Andhra Pradesh, Madhya Pradesh, Orissa and Chhotanagpur. These are derived from ancient crystalline and metamorphic rocks like granite and granite gneiss. Red soils are also found under forest vegetation. The colour of the soil is due to high diffusion of iron rather than its high proportion. Red soils are poor in nitrogen, phosphorous and humus and tend to be acidic.

#### *Laterite soils*

Laterite is formed through leaching of silica. These soils are found at the summits of the hills of Karnataka, Kerala, Madhya Pradesh, Eastern Ghat region of Orissa, Tamil Nadu, south-west of West Bengal and Assam hills. The soil may be rich or poor in nutrients depending on its location but are generally acidic in reaction. The clay fraction of laterite soil is rich in kaoline.

#### *Desert soils*

Desert soils are formed in low-rainfall areas. Sandy in texture and consisting mostly of quartz, feldspar and some hornblend. These soils are formed by the decomposition of country rocks like sandstone, quartzite, shale and other crystalline rocks. A large part of Rajasthan, Gujarat, Haryana, Punjab, and the area between the Indus valley and Aravalli range contain this soil. These soils generally have high pH and EC and are poor in organic matter, with varying percentage of calcium carbonate.

### **4.9 LAND CAPABILITY CLASS**

As per the International Land Capability Classification which has also been adopted in India, lands have been categorized into eight capability classes ranging from I to VIII. Lands belonging to classes I to IV are suitable for cultivation and those from V to VIII are not suitable for cultivation. Factors like texture, soil depth, permeability, slope, extent of erosion, degree of wetness and climatic conditions, particularly the rainfall are used to determine Land Capability Classification (LCC) . As a matter of convention, a particular colour code has been assigned to each of these classes of land so that they could be easily identified

when plotted in a map. A brief description of land from each capability class is presented below.

**A. *Land suitable for cultivation***

***Class I (Light green)***

In a map Class I lands are represented by light green color. These lands have very few or no limitations for growing common field crops. They are nearly level and the erosion hazard is low. The soil is deep, well drained, well supplemented with plant nutrients and responsive to application of fertilizer. Climate is favourable for growing a number of field crops. Availability of irrigation also removes the limitation posed by low rainfall in an arid region.

***Class II (Yellow)***

These lands have some limitations which reduce the choice of crops and require simple conservation practices. The limitations may result from gentle slope, slight susceptibility to erosion, less than ideal soil depth, wetness which can be corrected by drainage, slight to moderate salinity or sodicity that can be corrected easily, a slight climatic limitation etc. The limitations are slight or very few and corrective measures are easy to apply.

***Class III (Red)***

These lands have more limitations than those in Class II lands. The limitations of Class III lands may result from one or more of factors like moderately sloping land, moderate susceptibility to erosion, slow permeability, wetness or continuing water-logging even after drainage, shallow soil depth, low moisture-holding capacity, moderate salinity/sodicity, moderately limiting climatic conditions etc. Conservation practices are more difficult to apply.

***Class IV (Blue)***

Class IV lands have severe limitations that restrict choice of crops and require careful management. The restrictions in use of these lands are more than those for

Class III lands. The choice of cultivated crops is limited as result of permanent features such as steep slope, severe susceptibility to erosion, severe effects of past erosion, shallow soil depth, poor water-holding capacity, excessive wetness with continuing hazards of water-logging even after drainage, severe salinity or sodicity, moderately adverse climate etc. Very careful management is required if crops are grown at all. Conservation practices are more difficult to apply and maintain.

## **B. Land not suitable for cultivation**

### ***Class V (Dark green)***

Although, class V lands are nearly level and are not susceptible to much erosion, cultivation is not feasible for one or more limitations such as stoniness, wetness or severe climate. Class V lands are not suitable for raising cultivated crops but are suitable for perennial vegetation (grazing and forestry). It is practicable to apply pasture improvement practices such as seeding, application of lime or gypsum, application of fertilizer, rain water harvesting, provision of drainage etc.

### ***Class VI (Orange)***

Class VI lands have very severe limitations that make them generally unsuitable for cultivation. They have continuing limitations which cannot be corrected such as a steep slope, very severe erosion hazard, very serious effect of past erosion, stoniness, shallow rooting-zone, excessive wetness, low moisture-holding capacity, salinity or sodicity and severe climate. Soils in this class are subject to moderate limitations under grazing or forestry use.

### ***Class VII (Brown)***

Soils in class VII lands have very severe limitations that make them completely unsuitable for cultivation and restrict their use largely to grazing and afforestation. The physical condition of these lands are such that it is practicable to adopt pasture improvements and water-harvesting practices.

### ***Class VIII (Purple)***

The soils of class VIII lands are such that they preclude their use for commercial plant production and restrict their use to recreation, wild life food and cover, watershed protection or aesthetic application. The limitations which cannot be corrected may result from one or more of factors like severe erosion, severe climate, permanent wetness, stones, severe salinity or sodicity. It is, however, obvious that lands with higher LCC ratings (poorer lands) can be improved and converted to lower LCC (better lands) by adopting suitable reclamation practices. The guiding principles of land use practices are to use the lands according to their capabilities and treat the lands according to their needs.

#### **4.10 LAND CAPABILITY CODIFICATION (LCC)**

Since in a small watershed area, factors like climatic conditions, salinity, wetness, permeability etc remains more or less the same and unless they pose any special problems, these factors are normally kept in the background. The more frequently changing factors like soil texture, soil depth, land slope and erosion phases are the ones considered more important factors in arriving at the land Capability Class.

In order to describe soil texture, land slope and erosion phases, several standardized codes are used for their easy recognition. These codification have been arrived at by dividing the entire range of a particular soil characteristics into smaller groups and providing a symbol after adequately defining the specifications for the group. These symbols have wide application in soil survey and mapping practices.

##### **4.10.1 Soil Texture**

Soil texture is ascertained in the field by studying hand samples on the basis of experience and also applying the "Ball and Ribon formation method" described earlier in this chapter. Detailed mechanical analysis of representative samples may also be carried out in a laboratory. The major soil textures are Sand (s), Loamy Sand (ls), Sandy Loam (sl), Loam (l), Clay Loam (cl), Sandy Clay Loam (scl), Silt (si), Silty Loam (sil), Silty Clay (sic), Silty Clay Loam (sicl), Sandy Clay (sc) and Clay (c). Texture in conjunction with structure and presence of organic matter in the soil play, an important role in water-holding capacity, susceptibility to erosion,



aeration of the root zone etc. These in turn decide the suitability of crops to be grown. Texture, however, plays a minor role in determining LCC as texture not suitable for a particular crop may still be suitable for another crop e.g clay soil is not suitable for groundnut but is very suitable for paddy.

#### 4.10.2 Soil depth

Soil depth is ascertained in the field by examining into the soil section exposed in local ditches, gullies, streams, wells etc. If necessary, exploratory pits may be dug or a hand auger can be used. Sufficient soil depth is necessary for accommodating the development of roots. Soil depth with adequate permeability is also necessary for leaching of the salts from the root zone. The codification of soil depth into different classes is presented in the Table 4.5.

Description	Depth range, cm	Symbol	Depth class
Very shallow	0.0 - 7.5	d1	VI/VII
Shallow	7.5 - 22.5	d2	IV
Moderately deep	22.5 - 45.0	d3	III
Deep	45.0 - 90.0	d4	II
Very deep	Above 90.0	d5	I

**Table 4.5 Soil depth classes**

#### 4.10.3 Land slope

Ascertaining land slope in the field, could at times be difficult for an inexperienced observer. Use of a dumpy level gives land slope very accurately. However, during normal field visits a survey team may not carry one just for measuring the land slope.

Slope type	Slope, %	Symbol	Slope Class
Nearly level	0 - 1	A	I
Gently sloping	1 - 3	B	II
Moderately sloping	3 - 5	C	III
Strongly sloping	5 - 10	D	IV
Moderate steep	10 - 15	E	V

Steep	15 - 25	F	VI
Very steep	25 - 30	G	VI/VII
Very very steep	> 30	H	VIII

**Table 4.6 Land slope classes**

Slope ranges of 1-3% can be easily ascertained by visual inspection. Slope up to 10% can be ascertained by using two graduated rods, a rope and a spirit level. The use of a handy instrument known as Abney meter also provides land slope by measuring the angles in degree between two points. Use of Abney meter, however, requires sound knowledge of trigonometry.

Land slope limits safe and productive use of soil. The slope gradient and the length of slope affect the rate of run-off and soil removal and decide indirectly the amount of moisture absorbed by the soil. Land slope is most important factor in deciding LCC. The symbols for different slope classes are presented in the Table 4.6.

#### **4.11 SOIL EROSION**

Soil erosion may be defined as the detachment and transportation of soil particles from one place to another. Soil erosion inflicts the greatest damage to a land. An agricultural land loses its fertility when its top soil is lost. Severe erosion can turn a productive land into an unproductive waste within a few years.

It has been estimated (Dhruvanarayan and Babu, 1983) that in India about 5333 million tonnes of soil are lost every year due to erosion. The average rate of soil erosion due to agricultural activities alone is 16.75 tonnes/ha per annum. While 20% of this soil is lost to rivers and sea, 10% is deposited in the surface reservoirs created for irrigation. The remaining eroded soil gets deposited at various locations in the lower reaches. By the end of the sixth plan period, 117 major and 869 medium irrigation projects had been completed in India. At the time of the designing of these dams and reservoirs, the inflow of sediments was estimated to be in the range of 3.75-4.76 hectare metre per 100 sq.km per year. The actual sediment inflows in these reservoirs are now estimated to be much higher and in some cases 8 to 20 times these estimated figures. In general, we lose nearly 2.8 lakhs hectare per year of irrigation potential already created through these

reservoirs (Reddy, Ramakrishna, 1995). Adoption of large- scale watershed management projects in the country is expected to considerably improve the above situation.

Improvement in the status of land, water and plant resources through conservation measures is the key to natural resource management. The outcome of effective soil and water conservation measures in a watershed are:

- Reduction in soil erosion in general and top soil from arable lands in particular.
- Reduction in velocity of run-off, on site as well as in downstream areas, and utilization of the water for various purposes.
- Prevention of rapid reduction of storage capacities of the existing reservoirs due to soil erosion (siltation).
- Reduction of the severity of effects of floods and droughts during high and low rainfall years respectively.
- Augmentation of soil moisture status to support both agriculture and generation of other biomass.
- Augmentation of surface water storage and recharge of groundwater reservoirs.

Improvement in the status of land, water and plant resources through conservation measures is the key to natural resource management. The outcome of effective soil and water conservation measures in a watershed are:

- Reduction in soil erosion in general and top soil from arable lands in particular.
- Reduction in velocity of run-off, on site as well as in downstream areas, and utilization of the water for various purposes.
- Prevention of rapid reduction of storage capacities of the existing reservoirs due to soil erosion (siltation).
- Reduction of the severity of effects of floods and droughts during high and low rainfall years respectively.
- Augmentation of soil moisture status to support both agriculture and generation of other biomass.

- Augmentation of surface water storage and recharge of groundwater reservoirs.

Erosion and deposition are integral parts of the geological processes of nature. Although, the extent of erosion and deposition caused by the processes of nature can be retarded to some extent in selected areas with great efforts but there are no options to mankind but to accept such long term major natural changes. However, the interference of mankind with nature through activities like agriculture, destruction of forest, mining, construction works etc. also cause large scale soil erosion. It is this accelerated man-made soil erosion which is a matter of concern and must be prevented in order to maintain the productivity of our lands.

Soil is eroded by two basic elements of nature, namely the wind action and the water action. The only sure way to protect a land from the hazards of erosion is to adopt, as a matter of routine, such practices which prevent soil erosion. Soil erosion in any land should be viewed with concern and that of agricultural lands with utmost concern because this lead to the degradation of the land and consequently the entire natural resource base.

#### **4.11.1 Wind Erosion**

Organic matter and humus present in soil not only help in storing plant nutrients but also help in binding the soil particles together with each other. In an area where the soil is devoid of surface cover, organic matter and soil moisture, the finer particles (Silt) become loose and easily detachable. Strong wind, over a period, blows away the finer particles leaving the soil richer with coarser aggregates (sands).

Thus, in arid regions where rainfall is low and soil lacks in organic matter, the effect of wind erosion can be severe. The effect of strong uninterrupted wind can not only convert ordinary land into sandy desert but can further shift the loose sand from one place to another causing host of other problems as experienced in desert and coastal regions. In coastal regions the finer particles are washed away by the combined actions of wind and tides.

Sign of wind erosion is easily recognizable from the presence of dust in the air,

particularly during the summer months. Land could be saved from wind erosion by providing wind breaks (barriers) with plantation of hedges and trees across the general wind direction and enriching the soil with organic matters. *In situ* soil moisture conservation in the agricultural land through mulching, farm ponds, bunds, contour cultivation etc. have been found to be extremely beneficial. Most importantly, soil should be protected with vegetative covers where ever possible.

#### **4.11.2 Water Erosion**

Soil erosion by water takes place due to the transportation of soil particles by flowing water. Rainfall as the agent of erosion can operate in a number of ways. The impact of rain drops falling on the ground at a high momentum tend to break the soil structure and loosen the finer particles making them prone to be carried away. Also, when a part of the muddy water infiltrates, the finer particles are deposited within the pore space, blocking partially the upper zone of the soil profile. This results in the decrease in infiltration and thus increase in run off causing more soil erosion. The effects of erosion by water on land surface can be broadly divided as under.

##### **A. Sheet erosion**

In this type of erosion, a part of the top soil is removed rather uniformly from the land surface due to the common action of rainfall and run off. Effects of sheet erosion is comparatively more pronounced in sloping lands than in flat lands. Sheet erosion also takes place in flat agricultural land without sufficient protection. As sheet erosion takes place uniformly over the entire land, the extent of erosion most often is not understood by many farmers. For recognizing the quantum of soil loss due to sheet erosion, it should be noted that if 1 cm of top soil is eroded from one hectare (10,000 sq. m) of land, the volume of soil lost is  $10000 \times 0.01 = 100$  cum. Assuming an average particle density of soil as 2.65, the weight of this soil would be 265 tones/ha.

Whether an agricultural land is subject to sheet erosion or not is understood by noting the turbidity (colour) of the run off released from the land after a rainfall of high intensity. If the run off is muddy, the land requires further treatment. Run off from a well treated and stabilised plot will be free from turbidity.

## **B. Rill erosion**

It is an advanced form of sheet erosion. This type of erosion is easily recognized by a farmer by noticing the formation of small lines and depressions formed in the land by the flowing water immediately after a heavy rainfall. Though the land could easily be ploughed back to its original shape, occurrence of rill erosion in agricultural lands should never be allowed to take place. In unprotected non-arable lands, consequence of rill erosion is generally noticed in the nature of vegetation. In the long run either lower order (Xerophytic) species gradually replace the natural vegetation or the land becomes rocky (devoid of soil cover) and hence unable to support any vegetation.

## **C. Gully erosion**

It is an advanced form of rill erosion. Areas prone to rill erosion if not attended to, the rills extend in size in every passing years forming gullies. Gullies are formed where the run off develops high "cutting power" due to high velocity of the flow. The advanced stage of gully erosion leads to the formation of ravines. Lands affected by extensive gully erosion i.e the ravine lands are unfit for agriculture. It is, however, interesting to note that deep gullies are formed normally in lands having relatively thick soil depth. Efforts to reclaim ravine lands by levelling the same with mechanical means (tractors, bulldozers etc.) and following suitable agricultural practices attempted in some parts of the country have been found to be quite expensive.

Because of the climatic pattern, water erosion in India is more widespread than wind erosion. The effect of wind erosion, however, is quite severe in arid regions like Rajasthan and Gujarat. This does not mean that arid regions are less prone to water erosion. In fact, occasional high intensity rainfalls in arid regions are known to cause more erosion damage than the same rainfall could have caused in a humid region.

Features of erosion are largely judged by the conditions existing in the field. Slight erosion is usually associated with sheet erosion and moderate erosion with sheet and rill erosion. Severe erosion is associated with excessive surface erosion

exposing the sub-soil and is recognized easily by its tendency to form small gullies. Very severe erosion is associated with extensive loss of surface and sub-surface soil. It generally includes a few shallow gullies and occasional deep gullies. Erosion is a dominating factor in deciding land capability class. The major erosion classes are presented in the Table below.

<b>Erosion phase</b>	<b>Characteristics</b>	<b>Symbol</b>	<b>Erosion class</b>
Slight erosion (sheet)	1-25% top soil is removed	e <sub>1</sub>	I/II
Moderate (sheet and rill)	25-75% top soil is removed	e <sub>2</sub>	III
Severe (sheet, rill & gullies)	75-100% top soil and up to 25% subsoil are removed	e <sub>3</sub>	IV
Very severe (shallow gullies)	Gullied lands	e <sub>4</sub>	VI/VII
Very very severe (big gullies)	Very severely gullied lands	e <sub>5</sub>	VIII

**Table 4.7 Soil erosion phases**

The symbols used in Table 4.7 have extensive use in soil survey and mapping. Thus a land can be symbolized as say II - (d<sub>4</sub> - sl) / (A - e<sub>2</sub>) which would mean that the land belongs to Class II having a soil depth ranging between 45-90 cm (d<sub>4</sub>) which is sandy loam (sl). The land is nearly level (A) but erosion is quite visible (e<sub>2</sub>).

#### **4.12 PREPARATION OF LCC MAPS**

Soil and water conservation practice suggests that in an ideal situation, all lands particularly in a large watershed should be treated according to its use and capability. A land capability map super-imposed on a cadastral map presents a visual description of the potential and limitations of all lands within the watershed. This helps in planning the treatment measures to be applied in a watershed.

The standard practice for identifying Land Capability Classes of an entire watershed is to tabulate first, the major characteristic parameters, i.e soil texture, soil depth, land slope and erosion phases of each plot or a cluster of similar plots. The capability class of each of the parameters are then assigned alongside with the help of the rating tables. Local limitations, e.g salinity, water-logging, climate etc. are also taken into account. The final Land Capability Class to be assigned to the plot, will be the highest class number according to severity of limitations of any individual parameter as enumerated in Table 4.8.

Plot no.	Soil text.	Soil depth cm	Sym bol	Depth class	Slope %	Sym bol	Slope class	Ero. phase	Ero. class	LCC
110	cl	150	d <sub>5</sub>	I	1	A	I	e <sub>1</sub>	II	I
111	scl	60	d <sub>4</sub>	II	1	A	I	e <sub>2</sub>	II	II
112	sl	60	d <sub>4</sub>	II	2	B	II	e <sub>2</sub>	II	II
113	scl	30	d <sub>3</sub>	III	3	B	II	e <sub>2</sub>	II	III
114	ls	30	d <sub>3</sub>	III	3	B	II	e <sub>1</sub>	I	III
115	ls	15	d <sub>2</sub>	IV	7	D	IV	e <sub>2</sub>	II	IV
116	s	5	d <sub>1</sub>	VII	20	F	VII	e <sub>3</sub>	III	VII
117	l	10	d <sub>2</sub>	IV	4	C	III	e <sub>3</sub>	III	IV
118	cl	30	d <sub>3</sub>	III	3	B	II	e <sub>2</sub>	II	III
119	sil	60	d <sub>4</sub>	II	3	B	II	e <sub>1</sub>	I	II
120	cl	120	d <sub>5</sub>	I	2	B	II	e <sub>5</sub>	V	V
121	siel	60	d <sub>4</sub>	II	2	B	II	e <sub>1</sub>	I	II
122	sc	120	d <sub>5</sub>	I	1	A	I	e <sub>1</sub>	I	I
123	ls	60	d <sub>4</sub>	II	5	C	III	e <sub>2</sub>	II	III

**Table 4.8 Steps showing determination of Land Capability Class**

For example, a land defined by its codification can be grouped into its corresponding capability class immediately, as cited below.

**sl-d<sub>4</sub>/A-e<sub>1</sub>** :This symbol represents sandy loam (sl) texture with deep soil (d<sub>4</sub>), nearly flat (A) and slight erosion. As the highest limitation is soil depth (d<sub>4</sub>), the land is Class II..

**cl-d<sub>5</sub>/D-e<sub>3</sub>** :This represents clay loam (cl) texture with very deep soil (d<sub>5</sub>), strongly



sloping (D) and severe erosion (e3). As the highest limitation is severe erosion (e3), the land is Class VI.

**l-d<sub>3</sub>/B-e<sub>2</sub>**: This represents loam soil (l) texture with moderately deep soil (d<sub>3</sub>), gently sloping (B) and : moderate erosion (e<sub>2</sub>). As the limitations are moderate, the land is Class III.I

It should be noted that the above example is from a red soil area and hence permeability of the soil, as a limitation, has not been considered. Similarly, in an area with alluvial soil where the land is nearly flat, land slope is not considered for capability classification, instead, factors like wetness, permeability of top soil and the sub-surface layers, salinity/sodicity of the soil etc. are considered.

## ***5.0 Soil and Moisture Conservation***

---

### **5.1 RUN OFF AND EROSION**

Higher the velocity of run-off, higher is its sediment carrying capacity. For each soil particle, depending upon its size and density, there will be a corresponding flow velocity known as the critical velocity, at which the particle will start floating and be ready to be carried away. Experiments have shown that a velocity greater than 2 m/sec is critical for most soil particles. Experimental studies have also indicated that eroding power of a stream is proportional to the sixth power of the velocity of water. This means that if the velocity of a stream is increased by 2 times the carrying power increases by  $(2)^6 = 64$  times i.e soil particles 64 times larger in size than before would also be carried away. The converse is also true. Thus, if the velocity of a stream is reduced by half its original, the sediments that would settle down are 64 times bigger than those being carried away earlier.

A great deal of soil erosion can be prevented by controlling the velocity of run-off. Velocity of run-off under different ground conditions should necessarily be contained within the non-erosive velocity. The mechanisms through which the soil conservation measures are made effective by reducing the velocity of run-off include:

- Reduction in field size by constructing field bunds to decrease the rate of overland flow.
- Reduction in slope of land by levelling or terracing.
- Removal of excess surface run-off in a controlled manner by constructing contour ditches, diversion channels.
- Improvement in soil structure through application of organic matters to increase infiltration of rain water.
- Reduction in the physical impact of precipitation on the soil surface with cover crops/grass.
- Binding of the soil surface to reduce detachment of soil particles using conservation tillage..

- Reduction in the temperature of the soil surface using mulching.
- Trapping of eroded sediments through contour hedges and outlets with silt traps.

## 5.2 EROSION TRANSPORTATION

Run-off can carry away a large amount of soil as it flows along. The manner in which soil particles are carried away varies. The finer soil particles which remain suspended in water as they move along are known as *suspended load*. The heavier particles which move and roll along the bed of a stream are known as *bed load*. Some medium sized particles however are carried away in such a fashion that for some distance they float and for another they settle. These are known as *saltation load*. Which type of load will constitute maximum amount of sediment depends upon the flow velocity as well as the particle distribution of the soil. In most streams, out of the bulk of the sediment loads, nearly 80 - 90 % is suspended load. For this reason, the extent of top soil leaving a watershed is judged by studying the suspended load at the outlet of the watershed.

### 5.2.1 Measurement of Suspended Load

Measurement of suspended load leaving any cross section of a stream involves measurement of the cross sectional area (A), velocity of flow (V) and the concentration of sediments in the flow (C).

The suspended load (L) passing through a cross section is given by

$$L = A \times V \times C = Q \times C$$

Where,

Q = Discharge, m<sup>3</sup>/sec

C = Mean concentration of sediment, mg/litre

The discharge of a stream is measured by velocity-area method (Chapter 2). The concentration of sediment (C) is obtained by collecting water sample laden with suspended load in a special bottle of 1 litre size. The sediments filtered out from

the entire bottle by using a filter paper is weighed which gives the concentration of suspended load in gram/litre.

### **5.3 APPROACH TO CONSERVATION MEASURES**

The principle of soil conservation is based on the adoption of methods that will make the soil more cohesive at its place of occurrence thus making it less detachable in one hand and reduction of the velocity of the erosion causing agents that is the run-off and the wind on the other. It is therefore clear that conservation and management of rain water play the most important role in soil conservation. For this reason, both soil and water conservation measures are dealt with together as a common activity.

While the vegetational measures include growing of trees, shrubs, grasses, crops etc., the mechanical measures include construction of earthen, stone and masonry barriers and ditches for retarding velocity of run-off. The vegetational measures take time to establish before they start effectively serving their purpose but the mechanical measures give immediate result. From sustainable watershed development point of view, the vegetational measures are considered more permanent than mechanical measures, some of which have limited span of useful life. In an ideal situation, mechanical measures are introduced simultaneously with vegetative measures so as to facilitate the vegetative measures to take their roots and replace the functions of most of the mechanical measures in course of time. In arid regions, these measures serve the purpose of run-off harvesting while in humid regions, these retard the run-off to prevent soil erosion.

### **5.4 VEGETATIONAL MEASURES**

Vegetational measure involves planting of trees, shrubs and grasses not only with the objective of preventing soil erosion but also for serving the primary purpose of these trees and plants. Agronomical (crop production) practices adopted with a view to minimize soil erosion are also included under this measure. Vegetational measures can further be divided into two sub groups namely *Agrostological* practices and *Agronomical* practices.

#### **5.4.1 Agrostological Practices**

Under this practice, permanent trees are grown separately or in combination with grass or other field crops. A wide range of trees with grasses or field crops can be grown which not only protect the soil but also generate the much needed food, fuel, fodder, fruit, fibre and bio-fertilizer. Regeneration of highly degraded grazing lands (pastures) back to its health either by natural regeneration or by plantation of grasses and trees are helpful not only for soil conservation but also for livestock management. The choices under agrostological practices, however, are influenced heavily by the agro-climatic conditions, land capability class and preference of the land owners.

Growing of large (non fruit bearing timber or ornamental) trees are referred as *Silviculture* and that of fruit trees as *Horticulture*. *Silvipasture* is the practice where trees are grown in combination with grasses. *Silvipasture* is generally preferred in Class III and Class IV lands. *Agro-horticulture* is the practice where crops are grown in the spaces available in between the fruit trees during the initial years. Production of such crops are however discontinued as the fruit trees on maturity develop their own canopies e.g *mango*. *Agroforestry* on the other hand, implies growing trees in the bunds or in the agricultural land itself as block plantation, strip plantation or as scattered plantation with such species which grow in harmony with the crops e.g *Khejri, Babul, Seesam, Subabool*. *Farm forestry* means plantation of fast growing species with higher economical return from relatively less productive agricultural lands e.g *Eucalyptus, Casurina, teak* etc. Large area planted by a large number of tree growers with a few selected species for an industrial use is referred as *Industrial plantation* e.g *Bamboo, Poplar*. *Energy plantation* refers to plantation of species, the seeds of which provide bio fuel e.g *Zatropa, Castor*.

While giving economical returns as per the land capability, *Agrostological* measures are effective against both water and wind erosion. It is, however, important that the created measures are conserved properly over a long period to derive the benefits of the measures at their optimum level.

## **5.5 AGRONOMICAL PRACTICES**

All operations carried out in the field beginning with the land preparation to crop harvesting with the aim to increase the crop yield are included under agronomical

practices. Certain simple agronomical practices have been found to be more effective in retaining the soil fertility as well as give satisfactory crop yield. These are:

### **A. Tillage operation**

Tillage (ploughing) is the practice of breaking and working the soil to the desired depth prior to sowing. Tillage makes soil loose and hence prone to erosion. Timing and the depth of tillage are the two important factors which need special attention. Tillage should be done immediately before the crop season to take advantage of one or two early showers for land preparation. In arid regions, lands tilled into ridge and furrows across the wind direction has been found to reduce the effects of wind erosion. In humid regions, a land without any field bunds, if left as such after the tillage, can cause a great deal of soil erosion in a single season.

Depth of tillage should also be kept optimum keeping the aspects of soil erosion in view. Experiments have shown that minimum tillage does not affect the yield of many common crops particularly in dry land areas. In fact in dry lands, shallow ploughing helps in harvesting the previously existing (antecedent) soil moisture which would have otherwise been lost in case of deep ploughing. In humid climates, however, deep ploughing helps in controlling weed and in the improvement of soil permeability.

Direction of ploughing also assumes great importance in case of sloping lands. From soil and water conservation point of view, tillage along slopes should be avoided, particularly in an area with high rainfall. In order to minimize soil loss, tillage in these lands should be made along the contours i.e in the direction across (perpendicular) the slope. The tillage should also result in the formation of alternate ridges and furrows. Ridge and furrow cultivation is useful not only in reducing soil loss but also for efficient management of water for increased crop yield. Tillage along the contour line is referred as contour farming. Contour farming is effective for lands with slope up to 1-5%. All agricultural lands having slope greater than 5% should be converted into terraces.

### **B. Organic manure**

Organic matter is an integral part of soil. Soil bacteria convert a part of the organic matter into humus. Humus acts as a binding material of the soil particles. Since organic matters can hold more water than clay, a soil rich in organic matter will hold more soil moisture. Organic matters may be applied to the soil either directly or as a mulching material. Mulching is the practice of covering soil surface with plant residues so as to reduce evaporation, erosion and soil temperature. Mulching material offers physical protection to the soil against direct impact of raindrops. Mulching also helps in retaining soil moisture to a longer period which can be used very profitably in raising certain crops. After decomposition, the mulching material adds to the reserve of organic matter of the soil.

Demonstrations have shown the usefulness of mulching particularly in dry land agriculture. But, it is not followed regularly by farmers as most crop bi-products to be used as mulching material are also good fodder or fuel. Careful selection of mulching material is, therefore, called for. Polythene sheets have been used as mulching material successfully in many field trials. These sheets, however, can not be ploughed back to the soil as is the case with organic mulching materials. Organic matters can be applied to the soil directly but better if done after the necessary decompositions.

### **C. Crop rotation**

When one particular crop is grown in the same plot year after year, the land is likely to develop certain deficiencies. If the crop is *erosion permitting* in nature, the land is likely to get degraded. Similarly, due to this practice of mono-culture, the land may develop serious deficiency in certain plant nutrients. Sparsely spaced crops like *Jawar, Bajra, Maize* are erosion permitting crops. Densely grown crops like grasses, legumes and other deep rooted crops are *erosion resistant* crops. Erosion resistant crops should, therefore, be grown at least once in two years in the plots where such crops are not being grown, if the land shows visible signs of degradation. Also, two different crops could be grown in alternate strips every year.

The practice of mixed cropping or inter cropping is a further improvement to this concept. In mixed cropping one main crop is grown together with another subsidiary crop in the same field at the same time. Thus growing *Jawar, Bajra,*

*Maize* etc. in combination with pulses (*dal*), gram (*chana*) and other leguminous crops are advantageous. The broad leafed leguminous crops not only intercept rainfall and prevent soil erosion but also help in the fixation of nitrogen to the soil.

Combination of crops like Sorghum (Jawar) with pigeonpea or blackgram or soybean, Maize with soybean or pigeonpea or blackgram, Cotton with pigeonpea or blackgram, Groundnut with pearl millet or castor or pigeonpea, Wheat with mustard, Castor with tuber crops etc. have been found to be compatible, economic and profitable. The difference in the maturity period, crop height and compatibility are the important factors to be considered in mixed cropping.

#### **D. Strip cropping**

In strip cropping two or more crops are grown in alternate strips preferably across the slope. One strip of erosion permitting crop should be alternated with another strip of relatively more erosion resisting crop. In strip cropping, the entire land remains in a kind of balance. Soil eroded from one strip is retained by the next strip and the overall fertility of the land is maintained.

Another advantage of strip cropping is that it helps in reduction of pest attack on the crops. Since pests are mostly crop specific, one particular strip affected by one particular pest remains confined within that strip itself without spreading to the next strip thus preventing the spread of the pest attack to the entire field.

### **5.6 LAND LEVELLING AND FIELD BUNDS**

Mechanical measures refer to all physical measures applied in the field for the purpose of run-off management. These measures aim to store, retard and divert excess run-off as per the need under a joint soil and water conservation strategy. Following land treatments practices are very useful for both conservation and management of soil and water.

#### **5.6.1 Land Levelling**

Farm lands should be levelled for efficient management of water. Level lands allow more infiltration thus increasing soil moisture and leaching. This in turn



reduces run-off and hence the soil erosion. Levelling of irregular land is done by cut and fill method. Soil from the elevated portion is removed and placed into the depressed portion to finally obtain a level land.

In traditional method, soil in the elevated portion is first ploughed thoroughly and the soil is then scraped to the depressed portion by using bullock or tractor driven scraper. Proper levelling is ascertained by visual inspection. Fine tuning of the levelling is done later by filling the land with standing water and studying the depth of water at different parts of the field. If the land to be levelled is too large and the land shape is too irregular, a special levelling survey technique is to be used to identify areas for cut and fill. If desired, a mild slope may be provided to the field particularly in humid regions for the purpose of irrigation and drainage.

### 5.6.2 Field Bunds

Field bunds are small earthen bunds constructed in the field which are normally less than one metre in height. Field bunds which are constructed traditionally along the periphery of a field are known as peripheral or marginal bunds and serve two important purposes. Firstly, these act as plot boundaries and secondly these are most effective field measures for the conservation of soil and water. Bunds intercept run-off allowing water longer time to infiltrate which increases soil moisture and at times recharge groundwater.

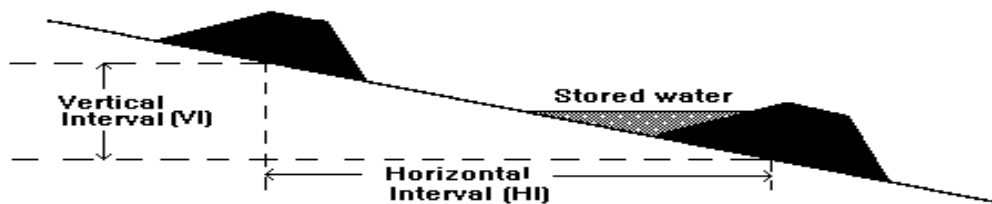

Fig. 5.1 Typical cross-section of land with field bunds

Ideally, the height and interval of field bunds, in a region, should be decided based on the

- rainfall pattern
- slope of the land and
- soil permeability

It has been estimated that nearly 5% of useful land is lost due to the construction of field bunds. Benefits due to the field bunds, however, far outweigh this minor loss of land. High field bunds in arid region also protect to some extent, the land from the hazards of wind erosion.

#### **A. Layout of field bunds**

Spacing between two contour or field bunds should be decided on the basis of the

- nature of soil
- land slope
- rainfall pattern
- cropping pattern and
- conveniences in agricultural operations.

Higher the slope, closer should be the spacing between two successive bunds and *vice versa*. Spacing may also be kept closer when soil requires more moisture. But closer the spacing, higher will be the cost of construction and loss of effective land area. When spacing between two contour (lateral) bunds exceeds 300 metres, it is advisable to introduce a supplementary bund in between. While constructing contour bunds, if narrow depressions or small mounds are encountered it is advisable to shape this irregularity before the construction of the bund rather than twisting the bund to cope with these minor topographical irregularities. The two longitudinal bunds constructed at the extreme ends of the contour bunds are known as side bunds. Spacing to be provided between two field bunds is normally expressed in terms of vertical Interval (VI) which is a function of the slope of the land. Vertical interval (VI) is the vertical difference of elevations between any two points along the slope. In order to obtain the optimum spacing between two contour bunds, the following formulae are used.

The general formula is:

$$VI = 0.3 (S/a + b)$$

a and b are constants to be established for a specific region on the basis of field experience. In India these values are taken as a=3 and b=2 which is more appropriate for higher slope ranges. Thus,

$$VI = 0.3(S/3 + 2) \quad \text{for sub humid/semi arid regions}$$

$$VI = 0.3(S/2 + 2) \quad \text{for humid regions}$$

$$HI = VI/S \times 100$$

Where,

VI = Vertical Interval

S = Slope of the land in percent

HI = Horizontal Interval

The above formula however does not take rainfall and permeability of the soil into consideration. An increase of about 25% of the above spacing is permissible for soils having poor infiltration rate and a decrease of about 15% is preferable for soils with high infiltration rate. The recommended spacing for contour bunds in lower slope ranges (0-6%) have , for ready reference, been presented in Table 5.1.

Land slope %	High rainfall		Medium rainfall		Low rainfall	
	VI	HI	VI	HI	VI	HI
0.0 - 1.0	0.46	46	-	70	1.0	107
1.0 - 1.5	0.53	36	0.70	50	1.22	97
1.5 - 2.0	0.61	30	0.75	40	1.37	76
2.0 - 3.0	0.76	25	0.80	30	1.52	61
3.0 - 4.0	0.91	23	0.90	25	1.68	52
4.0 - 5.0	1.06	21	-	-	1.82	40
5.0 - 6.0	1.22	20	-	-	2.0	36

**Table 5.1 Recommended spacing for bunds in lower slope ranges**

In the field, the measurements of the actual VI and the HI are not easy. It is rather the distance along the ground surface which geometrically represents the hypotenuse can be measured easily. Hence, after having decided the VI of the bunds, the actual distance on the ground is computed by using the following formula.

$$\begin{aligned}\sin \theta &= \text{Perpendicular/Hypotenuse} \\ \text{Hypotenuse (distance)} &= \text{VI}/\sin \theta \\ \theta &= \text{Slope of the land in degree}\end{aligned}$$

## **B. Cross Section of Field Bunds**

Stable and economical cross section for any bund is the trapezoidal cross section. At the time of construction, the height and side slopes of the bund are normally decided first. The bottom width of the bund gets automatically adjusted according to these two parameters. Volume of the earth work to be done is found out by multiplying area of cross section with the total length of the bund. Area of cross section of a trapezoidal bund is obtained from the following formula:

$$\text{Cross sectional Area} = [(\text{Base width} + \text{Top Width}) \times \text{Height}] / 2$$

$$\text{Total area lost due to bunds/ha} = (100 S/\text{VI}) \times b$$

Where,

b = Base width, m

S = Slope, %

## **C. Height of field bunds**

Height of field bunds are decided based on the rainfall and infiltration capacity of the soil. Most appropriate height is obtained first by deciding on how much water is to be impounded by each bund. Impoundment of about 30 cm of water by each bund for the maximum intensity for 10 years frequency is considered adequate.

While constructing new bunds an allowance to the extent of 50% should be provided for settlement.

Type of soil	Top width m	Bottom width m	Height m	side slopes	Area of section sq. m
Very shallow soil	0.45	1.95	0.75	1:1	1.00
Shallow soil	0.45	2.55	0.825	1.25:1	1.37
Medium soil	0.525	3.0	0.825	1.50:1	1.6
Heavy soil	0.60	4.20	0.90	2:1	2.4

**Table 5.2 Recommended dimensions of bunds**

In high rainfall areas, it is also necessary to provide an outlet in the bund usually at one corner, with suitable silt trap, to prevent breaching of the bund and soil loss. Standard trapezoidal cross section of bunds adopted in from most part of the country are given in the Table 5.2.

#### **D. Contour bunds**

Contour lines are the lines joining the points of equal elevation (height) across a sloping land. Contour bunds are constructed to intercept run-off flowing down the slope. Contour bunds help water to spread evenly and thus help retaining maximum amount of soil moisture. For an uniformly sloping land, bunds constructed in straight line across the slope will more or less follow the contour lines. In case of a land having varying degree of slopes, the layout of the contour bund will follow a serpentine line as per the slopes. Contour bunds are recommended for slopes up to 6%. Agricultural lands with slope greater than 6% should be formed into terraces.

Trenches instead of bunds constructed along the contour lines are known as contour trenches. These are useful in storing water along the trenches. While the emphasis in contour bund is in the conservation of soil within the agricultural land the contour trenches are constructed in waste lands primarily to conserve water (moisture) to support plantation activities.

#### **E. Graded bunds**

Graded bunds are those peripheral bunds where a gentle slope is provided along the base of the bund towards one end of the plot. Any excess water that may accumulate at the bund will thus flow towards one end of the plot which is drained out through an outlet. The flow may further be regulated by constructing a drain (furrow) along the inner boundary of the graded bund for gradual disposal of water towards the outlet. Grasses may be allowed to grow along the side and the bed of the drain. Draining of excess water from one plot to the other through the outlets provided in the bunds require special attention since considerable amount of soil may be lost through these outlets. Provisions should be made to arrest the silt and allow only clear water to flow away.

One of the low cost option in low rainfall area is to use the locally available stones (random rubble) for construction of outlets and allow the water to seep through the joints of the stone outlet. These joints in course of time, get filled up with silt and prevents further movement of soil. A deep ditch may also be constructed at the mouth of the outlet to act as a silt trap. The rate at which the silt trap gets filled in, is an indication about how prone the land is to soil erosion. Once the ditch is completely filled up with silt, these deposits should be removed and applied back to the field. In areas with high rainfall where the volume of water to be disposed from one plot to next lower level plot is large in quantity and the vertical interval between the plots are reasonably high, a site specific outlet design like pipe outlet or drop structure are to be provided for safe disposal of the excess water.

### ***Problem 5.1***

Calculate the minimum distance between two adjacent contour bunds to be constructed in a semi-arid region having an average slope of 6 percent.

### ***Solution 5.1***

Vertical interval is given by

$$VI = 0.3 (S/3 + 2) = 0.3 ( 6/3 + 2) = 1.2 \text{ m}$$

Again,

$$\tan \theta = \text{slope}$$

or,  $\tan \theta = 0.06$

or,  $\theta = \tan^{-1}(0.06) = 3.43 \text{ degree}$

As,

$$\sin \theta = \text{Perpendicular/hypotenuse}$$

$$\begin{aligned} \text{Hypotenuse} &= \text{Perpendicular}/\sin \theta \\ &= \text{VI}/\sin \theta = 1.2/\sin 3.43 = 1.2/0.059 = 20 \text{ m} \end{aligned}$$

Bunds should be located at a minimum distance of 20 m from each other in the field.

### ***Problem 5.2***

Design suitable height of the bunds in the above example if infiltration capacity of soil is 30% and maximum 24 hr rainfall for 10 years recurrence interval is 12 cm.

### ***Solution 5.2***

Here,

$$\begin{aligned} \text{Available rainfall (Re)} &= \text{Rainfall} - \text{infiltration} \\ &= 12 - 30 \times 12 / 100 = 12 - 3.6 = 8.4 \text{ cm} \end{aligned}$$

Recommended height of a field bund is given by

$$h = (\text{Re} \times \text{VI}/50)^{0.5} = (8.4 \times 1.2/50)^{0.5} = 0.449 \text{ m} = 0.5 \text{ m (say)}$$

Add 25% for free board and 10% for settlement

$$H = 0.5 + 0.125 + 0.05 = 0.63 \text{ m}$$

## 5.7 TERRACES

Terraces are series of flat platforms constructed across a sloping land which give rise to the formation of a step or bench like feature. Terracing is one of the most effective soil and water conservation measures for cultivation in sloping lands. Terracing of land is recommended for a slope ranging between 10 to 50 % and even more. Land terracing makes agriculture in the hill slopes possible without any significant loss of soil.

Terracing of sloping lands are done by cutting necessary depth of soil from upper part of the slope and filling the same at the down slope part so as to form a flat bench. Prior to the cutting and filling, maximum depth of productive soil is studied as deeper the cutting greater will be the width of individual terrace. Also, higher the slope of the land, smaller should be the width of the benches and *vice versa*. Typical cross-section of a bench terrace is shown in Figure 5.2.

### A. Design of terraces

As, the extent of Vertical Intervals (VI) between two adjacent benches are decided by the slope of the land to be terraced, the width of a bench is finally decided by the slope of the land.

i. The standard practice to obtain a suitable value for the VI, is to use the following formula.

$$VI = (S \times W) / (100 - S)$$

It should be noted that the formula used for obtaining VI for contour bunds i.e  $0.3(S/a + b)$  should not be used while working out the VI for terracing.

ii. Width of terrace is determined by the following formula:

$$W = (200 d)/S$$

Where,



W = Width of the terrace

d = Maximum admissible cutting depth (For vertical cut)

S = Slope of the land in percent

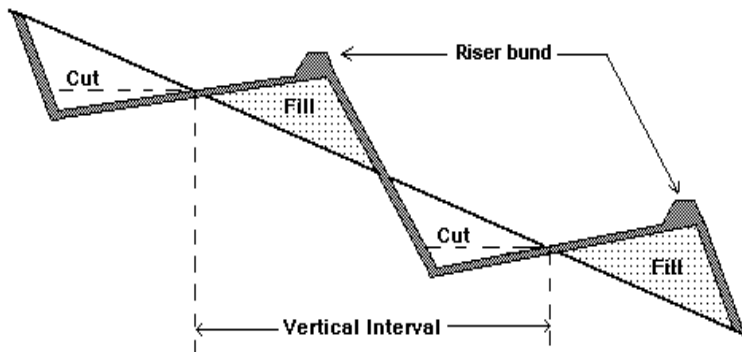

Fig. 5.2 Cross-section of inward sloping bench terraces

iii. Depth of cutting is normally obtained by using the following formula:

$$D = W/2 \times S$$

Where,

S = Slope in fraction i.e  $\tan \theta$

iv. Total percentage of land available per hectare after completion of terracing is given by:

$$P = \Sigma (L \times W) \times 100 / 10000$$

Where,

P = Percentage of land available per hectare

L = Length of each bench

W = Width of each bench

v. Cross section of a bench (both the cut and fill triangles) can be obtained accurately by using the following formula:

$$[W (VI + RH)]/ 8$$

Where,

C = Cross section of terrace

VI = Vertical Interval

RH = Reverse Height

vi. Earth work/ha =  $(100/8) \times W \times S$

## **B. Construction of Terraces**

To begin with the construction of terraces, marker pegs are first placed on the ground along two successive contour lines at interval equal to the terrace width. Another set of pegs are then placed at their mid-points. Sharp turn in the contour line is avoided. Soil is cut from the top half and filled in the lower half of the intended bench. Cut and fill is done gradually and at equal space. Soil should neither be too wet or too dry. This ensures correct grading without the risk of over cutting. Since, the riser bund (embankment) for each of the benches is made on the filled up side, it should have a good anchorage through small dug out ditch and be battered well to make it well seated on the slope. The cross section of the riser bunds should be so designed that no slipping takes place. Height of the riser bunds should have the provision of shrinkage for about 10%. The riser bunds are compacted and protected by grass plantation. Riser height should not exceed 1 m after settlement and side slopes should be around 0.75 :1 for loose soil and 0.5 : 1 for rocky soil.

Properly constructed terraces are either flat or slightly sloping inward. Flat terraces are preferred for crops like paddy which needs uniform impounding of water. Inward sloping terraces with drainage ditch along the inner boundary are preferred when the crops grown require proper drainage. Terraces are known as bench or broad based terrace depending upon their width. Length of the terraces are normally restricted by the land holding of the individual farmer but terraces generally are constructed to a considerable length along the hill side as community project. Longer terrace will cause more run-off specially if the soil is less

permeable. A very long terrace should, therefore, be intersected by surface drainage at about 100 to 150 m intervals.

Poor farmers may consider construction of terraces rather expensive. Terraces can also be developed over a long period by adopting a less expensive natural process. This may be done by constructing, low contour dykes across the slope at suitable intervals using earth or rock together with a ditch dug along the upper side. The contour dykes may be replaced or reinforced with hedge crops in a number of rows to prevent loss of soil at the bund. As normal agricultural operations continue in the strip of lands between the two dykes, soil moves down from the upper part of the strip to be deposited at the lower part thus forming natural terraces, over the years. This method when followed as per a recommended package of practices is referred commonly as Sloping Area Land Technology (SALT). The method is effective for gentler slopes but has been tried with good results in high slopes as well.

### ***Problem 5.3***

Calculate the vertical interval (VI) for terraces to be constructed whose bench width should become 3 m on land with 40% slope. Also calculate the depth to be cut for the construction.

### ***Solution 5.3***

Vertical interval for terrace is given by

$$VI = (S \times W) / (100 - S) = (40 \times 3) / (100 - 40) = 1.71 \text{ m}$$

Depth of cutting is given by

$$D = W/2 \times S \quad (S = \text{Slope in fraction})$$

$$D = 3/2 \times 0.4 = 0.6 \text{ m}$$

Width of terrace

$$W = 200D/S = (200 \times 0.6)/40 = 120/40 = 3 \text{ m}$$

## 5.8 GULLY PLUGS

Bunds constructed across gullies are known as gully plugs. Formation of gullies in an area is an indication that the area and its upper reaches are in dire need of soil and water conservation measures. An effective way to control the formation of gullies is to treat the upper reaches adequately and construct gully plugs to prevent further expansion of the gully. Excess run-off if any, which can not be easily controlled, should be disposed off through provision of proper diversion structures. Proper plugging of a gully not only stops further expansion of the gully but also initiates the process of filling up the gullies through deposition of soil. Usefulness of gully plug lies in its role in reducing the velocity of run-off to the downstream area.

Small and medium sized gullies can be plugged with temporary structures. Large gullies are to be plugged by constructing permanent masonry structure across the gully and providing adequate bank protection including diversion for excess run-off. A large number of gully plugs may be required to properly treat a highly degraded watershed. For this reason it is important that locally available materials and expertise be used to construct gully plugs so that the cost of these structures remain minimal.

A variety of materials can be used as gully plugs. It is, however, important to ensure that the size and compaction of the bund be adequate to withstand the peak run-off at the site for at least a frequency of 10 years. Gully plugs can also be constructed by driving to the ground wooden poles in series across the gully and blocking the in between passages with wooden planks or brush woods. These type of plugs though are cheap and easy to construct but large scale use of poles and plants should be weighed against the existing forest scenario of the area.

Stones, if available locally are the most suitable material for construction of loose boulder checks. Stable stone walls as high as 1 m can be constructed easily by using assorted boulders without using any cement. Even sand bags have been found to be effective gully plugs in arid and semi-arid regions. Cementing material like lime mortar or cement mixture may be used for larger sized permanent gully plugs. Effective stone plugs can also be made by using iron wire mesh (net) as the

holding material. The entire gully plug may be composed of a number of smaller stone plugs (blocks) called *gabions*. The *gabions* are formed by placing the requisite number of stones in a stable pack, which are then wrapped tightly with iron wire mesh. Properly placed gabions are then tied with each other with metal wires to form the complete gully plug of desired length. Gullies of almost all sizes can be plugged by using these *gabion bunds*.

## **5.9 OTHER MINOR STRUCTURES**

### **A. Field pond**

Ponds are normally small tanks, created essentially by excavation and does not necessarily require an embankment. Large ponds in alluvial area are excavated deep, in a step like formation which taps the groundwater. Pumps are necessary to extract water from ponds. Ponds also store rain water or other surface water diverted into the same. Field or farm ponds constructed in the arid region have been found to be effective in providing useful soil moisture to the crops through seepage. Stored water in farm ponds applied to crops during the gap period between two rains have been found to be extremely beneficial to the crops. Size of the farm pond is to be established based on the maximum expected period of gap that may occur between two subsequent rains, particularly during those critical periods of moisture requirement for the crop growth. Though, some useful cultivable area is lost because of the field ponds, such loss is more often compensated by an assured and increased yield in crops.

### **B. Diversion structure**

Diversion or disposal structures are required when the land is unable to absorb or retain the peak run off. The common diversion structures are drop spillway, chute spillway and open channels.

#### **Drop spillway**

Drop spillways are masonry structures which by design are similar to a weir but are much smaller in size. These are provided at locations where the land (run off channel) drops suddenly causing high degree of soil erosion. The objective is to

reduce the velocity of the flow to a sub-critical level and dispose of the excess water safely. These are commonly provided in the bunds (graded bund) of agricultural lands where the height difference between one plot to the other is more than 1 m. These are effective for controlling low head drops normally up to 3 m and discharge less than 1 cumec.

## Open channels

Open channels have wide use in the conveyance of water under gravitational head. Flow (discharge) through an open channel is directly proportional to the area of cross section of the channel (A) and the velocity of the flow (v) i.e  $Q = AV$ . Velocity of flow in an open channel is a function of the slope of the channel (head) and other factors like hydraulic radius which is the ratio of area and wetted perimeter. Semi circular cross section is hydraulically the most economic cross section for an open channel. For brick masonry channels, construction of rectangular section is convenient.

## Run-off Harvesting

In arid regions crops can be grown by harvesting run off from an adjacent catchment area where crops are not being grown thus allowing the cropped area an additional supply of water. The catchment area to cropped area ratio (CCR) can be computed approximately by using the following formula (Finkel,1985).

$$CCR = \frac{\text{Crop Water Requirement} - \text{Design Rainfall}}{\text{Design Rainfall} \times \text{Run off Coefficient} \times \text{Effective Rainfall}}$$

- Crop water requirement is estimated from evaporation data or by using Blanny - Criddle formula.
- Design rainfall should be taken slightly less than long term average.
- Run off Coefficient (Refer Table 6.1).
- Effective Rainfall is that part of rainfall which is available to crops.

## ***6.0 Water Harvesting Structure***

---

### **6.1 IN SITU WATER HARVESTING**

It is increasingly evident that there is a need to review the present approach of developing irrigation projects in the lower reaches at the cost of water to be drained out from the upper reaches. In situ conservation of water in the upper reaches in a large number of smaller water-harvesting structures is more beneficial than the construction of one large reservoir in the lower reaches. Micro-level (in situ) management of water offers greater advantage in meeting the water requirements of crops over a larger area. The argument is further elaborated below.

- Under in situ water management practices, attempts are made to store and utilize as much water in the upper reaches as possible. Conservation of water in the upper reaches not only helps in the production of biomass but also controls the flow of water in the streams and recharge to the groundwater. Since, the excess water in any case will eventually find its way downstream, controlling of water in the upper reaches provides a better water management option for the mid-reach and the valley areas.
- The associated philosophy of in situ water management practice is that in the upper reaches, one is entitled to only that water which precipitates in one's land and one has to learn to adopt techniques to raise crops and plants with this available water including groundwater. Any other cropping pattern will be unsustainable in the long run.
- A more equitable application of water in the entire watershed with higher water use efficiency is likely to help in growing assured crops in much larger area, giving larger cumulative yield than intensive use of water from irrigation reservoirs in the valley areas alone.
- The decentralized field-level management of water by the users themselves, within a watershed, requires very little establishment cost compared to that normally associated with most major and medium irrigation projects.

- Unit cost for canal irrigation is essentially much higher than that for in situ water management practices.

The major and medium-scale irrigation projects, however, are normally designed as multipurpose projects, mostly in high-rainfall and flood-prone areas which, apart from providing irrigation, are also designed to control floods, generate electricity, and to help recharging groundwater through a network of canals. It is being increasingly felt that the country has developed a sufficient number of major and medium irrigation projects, the outcome of which needs critical evaluation. The time has come to divert at least a fraction of these investments to watershed management, particularly in the dryland areas.

Conservation of water in the upper reaches help production of not only crops and other biomass, but also contributes in enhancing the soil moisture regime and under favourable conditions aid in recharging groundwater. Since the excess surface water will eventually finds its way downstream, controlling water in the upper reaches provides a much better water management option.

The associated philosophy of in situ water conservation practice is that one is entitled to only that much water as which precipitates in one's land. Hence one need to learn to adopt techniques to raise crops and plants with this available water. Any other cropping pattern will eventually be unsustainable.

A more equitable application of water in both the upper and lower reaches with improved water use efficiency is likely to help grow assured crops in much larger area giving larger cumulative yield than intensive use of water from irrigation reservoirs through canal systems.

The decentralized field level management of water by users themselves requires very little establishment cost compared to those with most major and medium irrigation projects.

The terms rain water harvesting or water harvesting structures simply storing of rain water or surface run-off in suitable structures usually small in size for *in situ* use of the tapped water e.g field bunds, gully plugs, contour trench. Rainwater collected via roof top for drinking and domestic use accordingly are known as roof



water harvesting. Water retention or storage structures on the other hand refers to larger structures constructed for the purpose of storing large quantity of surface and stream run-off e.g reservoirs, tanks. However, as the size of the structures usually remain in the background, the terms rain water harvesting refers to all kinds of water storage and utilization practices.

While large reservoirs are created by raising earthen bunds in large seasonal streams, small tanks may be created even by raising bunds across small large gully or depression. From the construction point of view, all reservoirs and tanks have two main components, namely the *earthen bund* and the *spillway*. While the earthen bund is the structure which impounds the desired quantity of water, it is the spillway which permits excess water to flow away, thus protecting the earthen bund from damage. Although the spillway or the waste weir should preferably be a masonry structure, a *katcha* outlet or pipe outlet may also be provided particularly in the case of small tanks.

The design considerations for a spillway and a check dam are more or less the same. The height of the spillway should be such that while the desired quantity of water is stored in the tank permitting only the excess water to be disposed of safely over the structure. The length of the spillway should be such that it can dispose of even the maximum flow that may occur, even once during the lifetime of the storage structure. For designing all water retention structures, it is essential to compute the expected peak discharge at the site of construction on the basis of the rainfall pattern of the area.

Water harvesting structures refer to all physical structures, small and big, constructed in the field for the purpose of storage of surface water flow. Thus, while the surface water storage tanks, check dams etc. are the larger water retention structures, gully plugs, field bunds etc are the smaller varieties. Large water retention structures require special engineering knowledge and skills for their design and construction. These are expensive, give immediate and visible results and have limited life span. Smaller water retention structures are easy to construct, have longer effective life span and give sustainable result.

## **6.2 COMPUTATION OF PEAK DISCHARGE**

The maximum rate at which water flows at any given cross-section of a stream, normally at the outlet of a watershed, is known as *peak discharge* or *high flood discharge* or *peak rate of run-off*. Computation of peak discharge is useful not only for understanding the watershed characteristics but also in designing safe water retention structures. It is well known that even if the intensity of a rainfall remains uniform throughout the watershed, the discharge at the outlet does not remain uniform. This variation is caused mostly by the difference in time of concentration of flows for different streams at the outlet and partly by the initial higher infiltration rate and other retention factors. The characteristics of discharge is understood better by studying a hydrograph which is a plot of the variation in discharge with time.

### 6.2.1 Empirical Formulae

Based on the catchment characteristics of the area under consideration, quite a few empirical formulae have been developed for estimation of peak discharge . Since these formulae are region specific, they should be applied judiciously.

Dicken's formula :	$Q = CA^{3/4}$
Ryve's formula :	$Q = CA^{3/2}$
Inglis's formula :	$Q = 124 A^{0.5}$
Irrigation department, Gujarat:	$Q = 67.3697 A^{0.6485}$

where,

- Q = Peak discharge, cu.m/sec
- C = Run-off coefficient
- A = Catchment area, sq. km

Dicken's formula is applicable for moderate sized basins of Northern and Central India. Value of 'C' is taken as 12 to 15 for areas having rainfall between 600 mm and 1200 mm. 'C' for Madhya Pradesh is taken to be from 14 to 20. Ryve's formula is applicable to South India. Value of 'C' varies from 7 to 15. For Tamil Nadu the 'C' value used is 8.5. Inglis's formula is used for fan-shaped catchments in Maharashtra.

It could be easily verified that while Ryve's and Inglis's formulae yield higher values of peak discharge, Dicken's formula yields a relatively lower value. Also, the peak discharge to be obtained from the Gujarat Irrigation Department formula is on the higher side. However, in the Gujarat formula, a reduction to 70% of the value is recommended for smaller structures.

### **6.2.2 Rational Formula**

This is one of the most popular and reliable methods. It is applied extensively for the estimation of peak discharge from a small catchment area and is given by:

$$Q = (CIA)/360$$

where,

Q = Peak rate of run-off, cu.m/sec

C = Run-off coefficient

A = Watershed Area, ha

I = Intensity of rain for the design return period (T) and for duration equal to the time of concentration (tc) of the watershed, mm/hr.

The method is based on the assumptions that

- the intensity of rainfall is uniform over the entire watershed, and
- rainfall of uniform intensity takes place at least for a duration equal to the time of concentration.

#### **A. Estimation of Run-off coefficients**

The value of the run-off coefficient (C) used in the Rational formula depends primarily upon the soil type, land-use and slope range of the watershed. Vegetative cover plays an important role in reducing the value of the run off coefficient C of a watershed. The recommended values of run-off coefficient for some typical slope groups and land-uses are presented in the Table 6.1.

Land use and Slope	Soil Texture		
	Sandy Loam	Clay & Silt Loam	Silty Clay
<b>Cultivated land</b>			
0 – 5%	0.30	0.50	0.60
5 – 10%	0.40	0.60	0.70
10 – 30%	0.52	0.72	0.82
<b>Forest Land</b>			
0 – 5%	0.10	0.30	0.40
5 – 10%	0.26	0.36	0.55
10 – 30%	0.22	0.42	0.60
<b>Pasture Land</b>			
0 – 5%	0.10	0.30	0.40
5 – 10%	0.25	0.35	0.50
10 – 30%	0.30	0.50	0.60

**Table 6.1 Recommended values of run off coefficient C**

Run-off coefficients mentioned for cultivated lands in the table above is for lands without sufficient protection. The value of the coefficient can be easily brought down to levels similar to those of forest lands when sufficient protection measures like bunding and terracing have been implemented in a watershed.

### **B. Design peak intensity (I)**

While constructing water retention structures, it is important to design them in such a way that they can carry safely the highest run-off that may be generated even once during the entire lifetime of the structure. This is done by computing the probability of highest intensity of rainfall intensity (I) that can take place for a given return period. The return period for the probable highest discharge is normally taken as equal to the expected life period of such structures. This design intensity is obtained from the intensity-duration-frequency relationship curves which can be developed if rainfall data over a long period are available. In the absence of such curves, the relationship between the intensity, duration (time of concentration) and frequency (return period) is computed from the following equation.

$$I = (K T^a)/(t + b)^n$$

where,

T = Return period, year

t = Time of concentration, hour

K,a,b and n are the coefficients

Station	K	a	b	N
Northern Zone	5.914	0.1623	0.50	1.0127
Dehradun	6.000	0.2200	0.50	0.8000
Jaipur	6.219	0.1206	0.50	1.1172
Jodhpur	4.098	0.1677	0.50	1.0359
Central Zone	7.465	0.1712	0.75	0.9599
Bhopal	6.930	0.1892	0.50	0.8767
Nagpur	11.450	0.1560	1.25	1.0324
Raipur	4.683	0.1389	0.15	0.9284
Western Zone	3.974	0.1647	0.15	0.7327
Aurangabad	6.081	0.1459	0.50	1.0923
Bhuj	3.823	0.1919	0.25	0.9902
Veraval	7.787	0.2084	0.50	0.8908
Eastern Zone	6.933	0.1353	0.50	0.8801
Agartala	8.097	0.1177	0.50	0.8191
Gaya	7.176	0.1483	0.50	0.9459
Jharsuguda	8.596	0.1392	0.75	0.8740
Southern Zone	6.311	0.1523	0.50	0.9465
Bangalore	6.275	0.1262	0.50	1.1280
Hyderabad	5.250	0.1354	0.50	1.0295
Chennai	6.126	0.1664	0.50	0.8027

**Table 6.2 Values of coefficients for Intensity-Duration-Return Period relationship, India, Source; (Ram Babu et al, 1979)**

### **C. Return Period**

The return period (T) to be considered for use in estimating the design Intensity is

normally kept equal to the lifespan of the structure under consideration. The recommended return period to be used in the rational formula for different types of soil and water conservation structures are presented in the Table 6.2.

Type of Structure	Return Period in Years
Large and medium dams with permanent spillway	50 – 100
Large earthen dams with natural spillway	25 – 50
Small earthen dams and overflow weirs	25
Small masonry gully plugs	10 – 15
Field diversions	15
Bund outlet, vegetative water ways etc.	5

**Table 6.3 Recommended maximum return period to be used for designing various types of structures**

Assumption of a return period has a great deal of economic significance. Higher the return period, higher will be the computed value of peak discharge. Again, higher the computed peak discharge, the stronger should be the structure constructed which in turn will render the structure more expensive. It is, therefore, customary to take a calculated risk by not assuming too high a return period so as to make a stable structure without rendering it too expensive by over-designing.

#### **D. Time of concentration**

Time of concentration ( $t_c$ ) is the longest time taken for water to travel by overland surface flow from the furthest point of the watershed to the outlet. Factors affecting the time of concentration ( $t_c$ ) of a watershed are its size, topography and shape. Thus,

- the larger the catchment, the longer will be the time of concentration and vice versa;
- the steeper the topography the faster the run-off and shorter the time of concentration;
- an elongated watershed will have a longer time of concentration than a circular watershed of the same size.

Time of concentration is computed by using the following empirical formula

$$t = (0.87LH)^{0.385}$$

where,

t = Time of concentration, hr.

L = Channel length in km

H = Difference in elevation between the furthest point and the outlet, m

The above formula can be reduced further to

$$t = 0.02L^{0.77} \times S^{0.385}$$

where, S = Average channel slope, m/m

### ***Problem 6.1***

Calculate the average value of run-off coefficient C of a watershed comprising 20 ha of forest land having clay loam soil with 20 % average slope, 30 ha of grass land having silty clay soil with 7 % average slope and 1800 ha of cultivated land having sandy loam soil with 2 % average slope.

### ***Solution 6.1***

From table 5.1, we have

Forest land having 10-30% slope with clay loam soil : C = 0.42

Grass land having 5-10% slope with silty clay soil : C = 0.50

Cultivated land having 0-5% slope with sandy loam soil: C = 0.30

Therefore,

$$\begin{aligned} \text{Average } C &= (20 \times 0.42 + 30 \times 0.5 + 1800 \times 0.3) / (20 + 30 + 1800) \\ &= (8.4 + 15 + 540) / 1850 = 563.4/1850 = 0.304 \end{aligned}$$

### ***Problem 6.2***

Compute the design peak intensity (I) at a site in Bhuj, Gujarat, for constructing a check dam (overflow weir) having 2000 ha catchment area comprising 800 ha wasteland with 5-10 % slope and 1200 ha of cultivated lands with sandy and sandy loam soil with 0-5% slope using rational formula. Time of concentration is given as 20 minutes.

**Solution 6.2**

a) Rational formula is given by:  $Q = CIA/360$

From Table 5.3, we have C values for wasteland and cultivated land as 0.55 and 0.3 respectively. Therefore

$$\text{Average } C = (0.55 \times 50 + 0.3 \times 1950) / (50 + 1950) = (27.5 + 585) / 2000 = 0.30$$

Time of concentration (tc) is given = 20 minutes = 0.33 hr

Rainfall Intensity is computed from the following equation:

$$I = KT^a / (t + b)^n$$

ble5.5, value of recurrence interval T is taken as 25 years

From Table 5.4, we get the values of K,a,b and n for Bhuj area as

$$K = 3.823, \quad a = 0.1919, \quad b = 0.25, \quad n = 0.9902$$

Therefore,

$$I = (3.823 \times 25^{0.1919}) / (0.33 + 0.25)^{0.9902} = (3.823 \times 1.854) / 0.583 = 12.2 \text{ cm/hr} = 122\text{mm/hr}$$

$$\text{Peak design discharge } Q = CIA/360 = (0.3 \times 122 \times 2000)/360 = 203.3 \text{ m}^3$$

**Problem 6.3**



Compute the time of concentration and the peak flow at the outlet of an elongated watershed whose distance from the furthest point to the outlet is 5000 m and the total fall of level is 50 m. The watershed is located at Jaipur, Rajasthan has an area of 1000 ha and watershed coefficient  $C = 0.5$ , compute the Peak discharge at the outlet of the watershed. .

**Solution 6.3**

Time of concentration is given by:

$$t_c = (0.87 \times L/H)^{0.385}$$

Here,  $L = 5000 \text{ m} = 5 \text{ km}$  and  $H = 50 \text{ m}$ , therefore,

$$\begin{aligned} t_c &= (0.87 \times 5/50)^{0.385} \\ &= (0.087)^{0.385} = \text{Anti log } (0.385 \log 0.087) \\ &= \text{Anti log } (-0.408) = 0.390 \text{ hr} = 23.4 \text{ min.} \end{aligned}$$

$$I = K (T)^a / (t + b)^n$$

From table 6.3 for Jaipur, we have

$$K = 6.219, \quad a = 0.1026, \quad b = 0.50, \quad n = 1.1172 \text{ and} \\ t = 23.4 \text{ min.} = 0.39 \text{ hr}, \quad T = 25 \text{ yrs (assumed)}$$

Therefore,

$$\begin{aligned} I &= (6.219 \times 25^{0.1026}) / (0.39 + 0.5)^{1.1172} \\ &= 8.652 / 0.878 = 9.85 \text{ cm/hr} = 98.5 \text{ mm/hr} \end{aligned}$$

$$\text{Peak discharge} = CIA / 360 = (0.5 \times 98.5 \times 1000) / 360 = 49250 / 360 = 136.8 \text{ m}^3$$

## **6.3 SURFACE WATER TANKS**

### **6.3.1 Site Selection**

Tanks or reservoirs are constructed by impounding water in seasonal streams or in long elongated natural depressions (valleys). Potential sites for construction of tanks can be located with relative ease by making queries with the local farmers about the existence of probable sites in the locality. Though, the local farmers most often identify potential sites for construction of some water retention structure or other, it is the responsibility of an experienced field staff to finally gauge the relative merits of the proposed sites. While selecting a site for a tank, the following aspects should be kept in mind.

- The size of the catchment area located in the upstream of the tank site should be such that adequate water is likely to be available at site for storage. Evaluation of the run-off coefficient of the catchment area assumes special significance in this regard.
- The ownership of the sites should be such that they are available for construction, allowing the necessary submergence.
- The storage capability of a tank depends upon the slope of the storage area (longitudinal section) and the height of the bund. Steeper the slope of the storage area, lower the storage per unit height of the bund. The site should ensure adequate storage capacity without undue extension of the submergence area. The storage area should be enlarged by excavation wherever feasible.
- The permeability of the soil in the storage area should be such that the likelihood of sub-surface infiltration is minimum in the case of a storage tank and maximum in the case of a percolation tank.
- The downstream area should permit natural passage for safe disposal of excess water.
- The site should be such that the length of the bund is not increased unnecessarily, particularly at sites where side bunds become necessary due to the unfavourable (flat) bank topography. Both the banks of the stream should be steep enough to ensure this.
- Finally, it will be important also to estimate the volume of water the tank can

safely store, the extent of area it is likely to irrigate and the socio-economic status of the landowners.

### 6.3.2 Design Criteria

A tank bund is an earthen dyke constructed across a large gully, depression or a seasonal stream for impounding water. A properly constructed earthen bund provided with an appropriate spillway can dam even large rivers. The most suited cross-section of an earthen bund is trapezoidal (Figure 6.1).

The important dimensions of an earthen bund are its top width, side slope and height. Once the height ( $h$ ) and top width ( $a$ ) of a bund are decided, the dimension for base width ( $b$ ) works out automatically according to the side slopes to be provided.

#### a. Height

The height of a bund is determined taking the following factors into consideration:

- Maximum permissible storage level of the reservoir.
- The amount of free board to be provided (minimum 1.0 m)
- The height of the spillway
- The amount of allowance for settlement (10 - 20%)
- Depth of foundation. Deeper the foundation beneath the bed level, higher will be the total height of the bund.

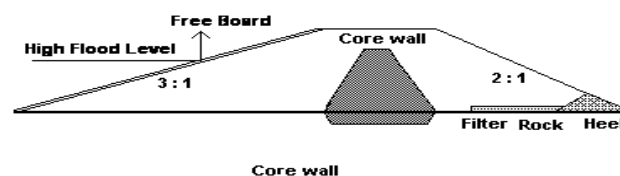

Figure 6.1 Cross sectional view of an earthen bund

***b. Side slopes***

Side slopes of a bund depend upon the nature of the soil to be used. For normal coarse-graded soil containing 20 to 40 % silt and clay, a side slope of 2:1 ( 2 horizontal, 1 vertical) for the water side and 1.5:1 for the downstream side are recommended. If the soil available is rather sandy, the side slopes should be increased to 3:1 and 2:1 respectively. The side slopes should be such that the soil should not show the tendency towards slipping. As saturated soil is less stable than dry soil, for the sake of safety, the upstream slope of the bund is kept flatter than that of the downstream slope. Some State Government departments recommend as a thumb rule that, for a tank bund, the minimum base width should be about 4 times the height and 8 times the top width.

***c. Top width***

The top width of a bund is usually chosen more or less arbitrarily, depending upon the purpose for which it will be used. For example, in case of large irrigation reservoirs, top width of the bund is kept wide enough to allow a vehicle to move easily over it. For a bund with a given height and side slope, the larger the top width, the larger will be the base width of the bund.

***d. Core wall***

An earthen bund will not be stable if seepage of water through the main body and from below the bund is not prevented. In order to do so, a core wall is provided, particularly in the larger bunds. The core wall is constructed, in a trapezoidal cross section, using impervious material like clay soil with adequate compaction. Sometimes, where soil is sandy, even a masonry or concrete core wall is provided. The base of the core wall is extended below the ground level to a depth up to the foundation or roughly equal to  $\frac{1}{3}$  to  $\frac{1}{4}$  of the water column. The top of the core wall is kept 30 to 50 cm above the high flood level.

The purpose of the core wall is to add strength to the bund and also to increase the gradient of the seepage lines. An earthen bund constructed without a core wall will have flat seepage lines which are likely to intersect the bund at its downstream face, making the bund unsafe. For safety, there should be no seepage through the

bund and, if there is any, the seepage should have a high slope so that it intersects at the base of the bund. A longitudinal drain parallel to the cut-off trench and cross drains at intervals also help in providing good drainage to any water that may enter by seepage through the heart of the dam or from rainfall. The slope of the seepage lines normally are 3:1, 5:1 and 6:1 for clay soil, sandy loam soil and sandy soil respectively. Presence of a core wall either prevents the seepage through a bund altogether or renders the slope of the seepage lines steep enough to make them intersect at the base of the bund.

### **5.8.3 Construction Procedure**

- The site is cleared of all stones, bushes, roots etc. The topsoil is piled up in a heap out of the way to be used later as dressing material.
- The layout for the main embankment and that of the spillway are marked at site using pegs or lime powder.
- The main cut-off trench is dug out. If the stream cross-section is too steep, the cut-off trench should be dug out in steps. A few smaller ditches parallel to the cut-off trench and some cross-drains are also dug out for provision of drainage.
- The cut-off trench is filled up with the best available clay and is compacted layer by layer up to the desired height to form the core wall after adequate compaction of each layer. The cross drains are packed with gravel.
- Laying of pipes etc. for the provision of outlets, if any, should be undertaken prior to raising the main bund.
- Excavated earth is laid over the core wall layer by layer with adequate compaction to form the bund to requisite dimensions. The earth-fill should be free from stones, roots and branches of trees etc. For larger bunds, compaction is normally achieved using road rollers after slightly moistening the earth-fill.
- A properly designed spillway must be constructed at a suitable location on the bund to allow excess water to flow out. Location of the spillway could either be at the central part or at any one end depending upon site conditions.

### **6.3.4 Precautions for Larger Structures**

In order to increase the stability of a bund, the following precautions should be undertaken, specially for large bunds.

- Water should never be allowed to flow over the earthen bund. To prevent overflowing, sufficient free board and a properly designed spillway with proper height and length must be provided.
- The extension of the spillway should be embedded sufficiently deep within the bund.
- The upstream slope of the bund should be protected by providing an adequate margin of slope and stone pitching to prevent scouring by wave action.
- The top of the dam should be given a gentle slope towards the water side to drain rainwater.
- The seepage flow passing under the bund when it reaches the discharge surface should have pressure and velocity so low that it is incapable of moving any material from the foundation of the bund.
- The seepage lines passing through the bund should not cut across the downstream face of the dam and should remain well within the base of the bund but closer to the downstream face. Provision of a filter bed and a rock toe at the base of the downstream face helps in safe disposal of seepage water.
- If, the soil to be used for the bund is sandy, both the upstream and downstream slopes should be made flatter than the recommended 2:1 and 1.5:1.
- Sufficient (up to 20%) provision for settlement of the bund may be provided. The bund should be ship-shaped after a year or two after settlement is complete.

## **6.4 OVERFLOW WEIR**

A weir is basically a gravity dam or a retention wall in which stability is obtained more from its own weight and buttresses provided on the downstream side. To further reinforce its stability, it is anchored into a solid foundation.

### **6.4.1 Site Selection**

The criteria for selection of a technically sound site for construction of a check dam are:

- Presence of rock formation at shallow depth of the stream bed. This provides a stable foundation for the weir. Sites with thick loose formation in the stream bed should be avoided as far as possible from both stability and cost of construction points of view.
- The stream at the site should be as straight as possible to cause minimum bank scouring (erosion).
- The stream should have narrow width and good depth so that the length of the weir remains short and the height can be increased to permit sufficient channel storage.
- The longitudinal slope of the stream bed on the upstream side should be gentle so that a larger volume of water can be stored per unit height of weir.

#### **6.4.2 Design Criteria**

The forces that normally act on a weir and their consequences are :

- Water pressure on the upstream face of the weir which may either cause forward sliding or overturning of the structure.
- Weight of the weir to the foundation which helps in its stability.
- Uplift pressure (buoyancy) which may cause overturning and is counter-balanced by the weight of the weir.
- Crushing effect of water and other debris that may flow over the weir.
- Expansion and contraction due to temperature variations which may lead to development of cracks resulting in weir failure.

The plan and elevation of a standard overflow weir is presented in Figures 6.2a and 6.2b.

#### **6.4.3 Design Parameters**

The most economic cross-section of a weir is trapezoidal (Figure 6.3) with the

vertical side facing upstream.

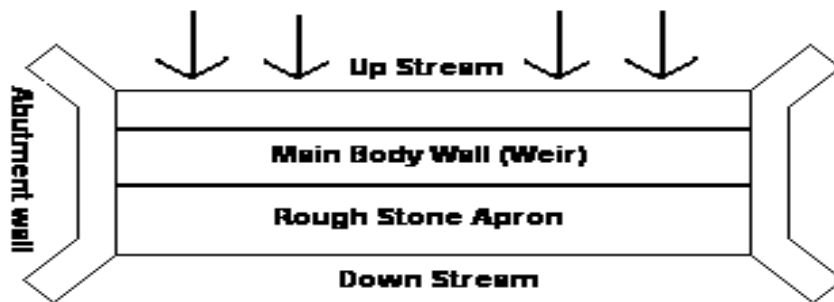

**a. Crest width**

The crest should be strong enough to cope with the impact of floating materials, logs, debris etc. which are to be displaced over the weir. The crest width is usually determined by the following formula:

$$a = 3h/2S$$

where,

a = Crest width, m

h = Flood depth over the crest, m

S = Specific gravity of the construction material

*Cement concrete* = 2.4

*Stone masonry* = 2.1

*Brick masonry* = 1.9

Minimum recommended crest width however are 0.35 m for walls up to 1.0 m high, 0.4 m for walls up to 1.0 - 1.5 m and 0.5 m for those 1.5 - 2.0 m high. If the overflow depth is expected to be high, a minimum crest width of 1.0 m is



recommended, irrespective of the height of the wall.

**b. *Bottom width***

Bottom width is given by

$$b = \frac{1.5 H + h}{S^{0.5}}$$

Where,

b = Bottom width of weir, m

H = Height of body wall (weir) above bed level, m

h = Flood depth over the crest of weir, m

S = Specific weight of construction material

A gentle slope or a step-like feature is provided in the downstream body-wall so that, at any point, the base width remains equal or greater than the crest width plus two-third of the height, i.e  $b = a + 2/3h$ .

**c. *Length of weir***

The length of broad-crested rectangular weir is obtained from the empirical formula

$$Q = CLh^{1.5}$$

where,

Q = Peak discharge, cu.m/sec

L = Length of weir, m

h = Permissible flood depth, m

C = Coefficient (1.7 is satisfactory for estimates)

For a given discharge, any reduction in the spillway length will increase flood depth causing water to flow to a higher level above the weir. In order to reduce the cost it may sometimes be necessary to reduce the length of the weir at the cost of

increased flood depth. Flood depth, however, should not be allowed to exceed 1.5 -2.0 m. The height of the side walls, i.e the abutment walls should be made such that a minimum of 0.5 m margin of free board above the highest flow level is maintained.

#### **6.4.4 Construction of a Weir (Check dam)**

- The site is first excavated to expose the rock surface or the stable strata (foundation). The rock surface is chiselled to form a rough surface for laying the foundation.
- A slurry of 1:3 (cement and sand) is laid to a minimum thickness of 10 mm to provide a good bondage.
- 1:3:5 cement-concrete is laid to a thickness 0.2 - 0.5 m to form the foundation for the body wall. The body wall is constructed with plain cement-concrete, or stone masonry, depending upon the site (flow) conditions.
- For the foundation, concrete should be poured in layers not more than 0.3 m at one time and should be thoroughly compacted.
- For a cement-concrete weir, clean water should be used to mix the concrete. Clean medium to fine sand and 20-40 mm diameter stone aggregate are ideal. Concrete should be kept moist and be allowed to cure for more than 7 days and preferably up to 27 days. Steel, timber or brick shuttering could be used.
- For a stone masonry weir (body wall), dressed, good quality stone blocks must be used. The body wall should be underlain by a plain cement-concrete foundation of 0.5-1.0 m thickness. The body wall should later be plastered with 1:3-1:5 cement paste.
- Laying of a stone masonry floor, known as an apron, in the upstream side bed level helps preventing excessive seepage and scouring. The toe of the apron should be extended down to the foundation to prevent seepage from below the check dam. Alternatively, impervious clay or polythene sheets could be spread in place of the apron.
- Velocity dissipaters should be provided on the downstream side for reducing the velocity of falling water. Provision of step-like platforms and a water trough are useful in absorbing the impact of falling water. If hard rock is

not exposed on the downstream side, the construction of a downstream apron may also be necessary.

- Sometimes a metal pipe with a gate valve is embedded across the weir at the time of construction itself to provide an extra outlet for safety and also for washing away of the silt deposits from the upstream side by allowing the flow through the pipe.
- The body wall should be well embedded into both banks of the stream through suitable extensions.

## 6.5 STABILITY CHECK OF A WEIR

Referring to Figure 6.3, we have,

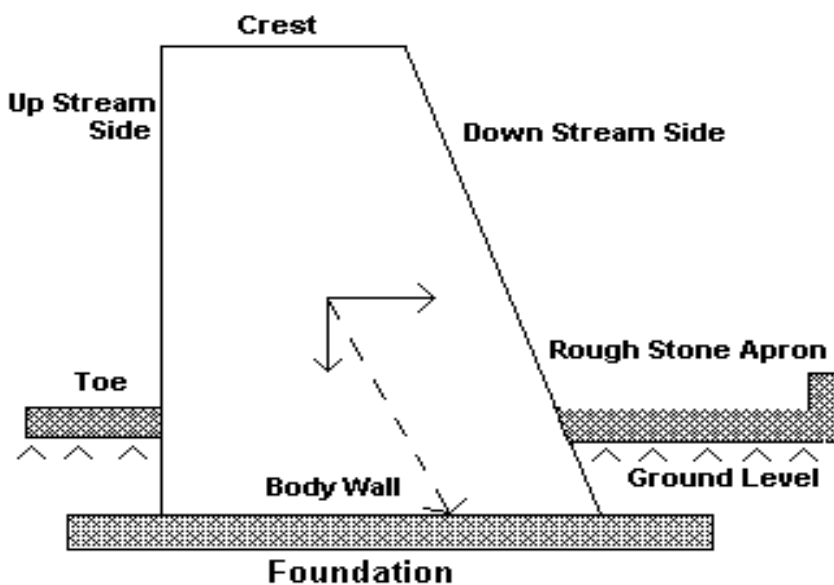

a. The weight ( $W$ ) of the weir per unit length acting vertically downwards is given by volume multiplied by density. Thus

$$W = (a+b) / 2 * H * d$$

This force acts at the centre of gravity at point  $M$  located at a distance  $N$  from the vertical face  $AD$ . Value of  $N$  is given by:

$$N = [(a^2 + ab + b^2)] / 3 (a + b)$$

b. Horizontal water pressure (P)

$$P = SX$$

where,

S = Specific weight of water

X = Depth below water surface at which pressure is measured

Pressure at the water surface is zero, as  $X = 0$  and that at the base is  $SH$  as  $X = H$ .

c. Total horizontal water pressure at point M is given by the area of the pressure intensity diagram as

$$P = H/2 \times SH = [S \times (H^2)]/2$$

When water level reaches the top of the weir, the resultant force acting on the weir at point M is given by  $R = \sqrt{(P^2 + W^2)}$  which intersects the base AB at point F. Again, when there is no water, the horizontal pressure  $P = 0$  and the resultant is given by  $R = W$  which intersects the base AB at point E. The distance EF is known as shift of reaction (Z) and the distance OF as eccentricity (e).

d. To avoid tension within the structure, the eccentricity (e) should not be greater than  $b/6$  about the point O. That is the resultant R should remain within  $1/3$  rd on each side from the point O, i.e within the middle third of the base. The extreme limit of F will be

$$AF = 2/3b$$

$$\text{or, } BE + EF = 2/3b$$

$$\text{or, } N + Z = 2/3b$$

therefore, for a condition of no tension  $N + Z$  should be less than or equal to  $2/3b$

### 6.5.2 Safety against Sliding

The horizontal pressure  $P$  tends to push the weir forward but the frictional resistance at the base tries to counteract this force. If  $u$  be the coefficient of friction then frictional resistance developed is equal to  $uW$ . Hence for stability against sliding,  $P$  must not exceed  $uW$ . Value of  $u$  is normally taken as 0.5.

### 6.5.3 Safety against Overturning

The overturning moment due to horizontal pressure  $P$  about the point  $M$  at  $H/3$  is given by  $P \times H/3$  and the balancing moment is given by  $W \times Z$ . For the sake of equilibrium the balancing moment should be equal to the overturning moment. Hence

$$W \times Z = P \times H/3$$

or,  $Z = PH/3W$

The weir can actually overturn about the point  $B$ . But as long as the resultant  $R$  lies between  $EB$ , the weir is stable. It will overturn only if the resultant  $R$  intersects beyond  $A$ . This happens when the centre of gravity  $M$  is far too close to the face  $BC$  due to wrong selection of the parameters  $a$  and  $b$ .

### 6.5.4 Safety against Crushing

In order to avoid crushing, the compressive stress acting normal to the base  $f_{\max}$  must be less than the maximum permissible compressive stress of the masonry and less than the bearing capacity of bed soil/foundation. Maximum vertical compressive stress ( $f_{\max}$ ) is given by  $W/b(1 + 6e/b)$  and this should be less than the bearing capacity of the soil at the foundation. Bearing capacity of soil is taken as 25000 kg/sq.m.

Thus to summarize:

- There should be no tension induced at any point on a horizontal plane through the body of the weir. The line of resultant force when the reservoir is empty or full should lie within the middle third zone of the profile of the dam (base of the weir).

- The foundation bed should not settle nor fail by shear under the load of the weir.
- The material used should be strong enough to prevent crushing of the body under the pressure of water.
- The weir should not crack due to the expansion and contraction caused by temperature variation.
- The shear stress of the masonry weir should be less than permissible induced shear stress at the toe and heel (base) of the weir.
- The uplift if any, should be considered because uplift causes overturning moment.

#### ***Problem 6.4***

Given the following data, design the basic parameters of an earthen bund.

Reduced Level (RL) of stream bed = 100.00 m  
 RL of top of the spillway = 103.0 m  
 Slope of saturation line (sandy soil) = 4:1  
 Assume other data

#### ***Solution 6.4***

Depth of water up to waste weir = 103.00 - 100.00 = 3.00 m  
 Allowable flood depth over waste weir (assumed) = 1.0 m  
 Free board to be provided (assumed) = 2.0 m  
 Height of earthen bund = 3.0 + 1.0 + 2.0 = 6.0 m  
 Provision for settlement of soil (10%) = 10/100 x 6.0 = 0.60 m  
 Gross height of the bund = 6.0 + 0.60 = 6.60 m  
 Top width of the bund =  $H/5 + 1.5 = 2.75$  m (say)

Adopt upstream and downstream slopes as 2:1 and 1.5:1 respectively.

Base width as per top width and side slopes = 24.8 m  
 The length available for saturation line = 16.50 m.

With above specifications, the saturation line meets the downstream face just about

at its base. Hence a clay core wall is to be provide to increase the slope of the saturation line. However, to ensure greater safety, stone filters may also be provided at the base of the bund parallel to the cut off trench.

### ***Problem 6.5***

Given the following data, design a suitable masonry overflow weir and check its stability:

Bed level (wrt) a temporary bench mark of 100 m) :	136.52 m
Maximum permissible submergence level (MPSL) :	139.14 m
Catchment area (A):	350 ha.
Intensity of rainfall (50 yr. return period):	90 mm/hr.
Run off (Catchment area) coefficient:	0.40
Silt factor (F):	1.0
Depth of hard strata below bed level:	1.0 m
Width of the stream at the construction site (L):	30 m
Density of stone masonry (S):	2.2gm/cc
Coefficient of friction (u):	0.50
Bearing capacity of foundation soil:	25000 kg/m <sup>2</sup>

### **Solution 6.5**

#### **a. Maximum flood discharge (Q)**

$$Q = CIA/360$$

$$= (0.4 \times 90 \times 350)/360 = 35 \text{ cu.m/sec}$$

#### **b. Depth of maximum allowable flow over the weir (h). Using Weir formula,**

$$Q = 1.71 \times L \times h^{1.5}$$

$$h^{1.5} = 35/(1.71 \times 30) = 0.682$$

$$1.5 \log h = \log 0.682$$

$$\log h = \log 0.682/1.5 = \log 0.454 = - 0.3423$$

$$h = \text{Anti log}(- 0.3423) = 0.454 \text{ m}$$

Say, 0.5 m which is very much acceptable for a weir of length 30 m.

**c. Height of body wall above bed level (H)**

$$\begin{aligned}\text{Full tank level (FTL)} &= \text{MPSL} - h \\ &= 139.15 - 0.50 = 138.65\end{aligned}$$

$$\begin{aligned}\text{Height of body wall} &= \text{FTL} - \text{Bed level} \\ &= 138.65 - 136.52 = 2.13 \text{ m.} \\ &\text{Say, 2.2 m}\end{aligned}$$

**d. Top width (a)**

$$\begin{aligned}a &= 3h/2S \text{ but not less than } 0.5 \\ &= (3 \times 0.50)/(2 \times 2.2) = 0.34 \text{ m} \\ &\text{say, } 0.5 \text{ (empirical, subject to adjustments)}\end{aligned}$$

**e. Bottom width (b) at the foundation**

$$\begin{aligned}b &= (1.5 H + h)/S^{0.5} = [(1.5 \times 2.2) + 0.50]/1.483 = 2.56 \text{ m} \\ &\text{say, } 2.5 \text{ m (empirical, subject to adjustments)}\end{aligned}$$

**f. Discharge per unit width of stream (q)**

$$q = Q/L = 35/30 = 1.16 \text{ cumec /m}$$

**g. Scour depth (R)**

$$R = (1.35 q^{0.33})^F = (1.35 \times 1.16^{0.33})/1 = 1.42 \text{ m}$$

**h. Foundation depth**

Foundation depth is kept 1.5R from the MPSL or up to the hard strata

$$1.5 R = 1.5 \times 1.42 = 2.1 \text{ m}$$



Since hard foundation is expected at 1.0 m, body wall may be extended 0.7 m below bed level and foundation may be laid to 0.3 m thickness.

### Stability check

Referring to Fig. 6.3

#### a. Safety against tension

i. Weight of the dam per metre:

$$\begin{aligned}\text{Weight of body wall } (w_1) &= (a + b)/2 \times H \times p \\ &= (0.5 + 2.5)/2 \times 3.2 \times 2200 = 10,560 \text{ kg}\end{aligned}$$

$$\begin{aligned}\text{Weight of the base } (w_2) &= \text{Length} \times \text{Thickness} \times \text{density} \\ &= (2.5 + 0.4) \times 0.3 \times 2200 = 1914 \text{ kg}\end{aligned}$$

$$\begin{aligned}\text{Total weight of the dam} &= (w_1 + w_2) = 10,560 + 1914 \\ &= 12,474 \text{ kg/m}\end{aligned}$$

ii. The maximum horizontal pressure (Overflowing condition)

$$P = Wh^2 / 2 = 1000 \times 4 \times 4 = 8,000 \text{ kg}$$

iii. The distance of the point of application of force from vertical face (AD)

$$\begin{aligned}N &= (a^2 + b^2 + ab)/3(a + b) = (0.25 + 6.25 + 1.25)/3 \times 3 \\ &= 7.75/9 = 0.86 \text{ m}\end{aligned}$$

iv. The distance of point of application of force E (weight) at the base of the section from the mid point of the base (O)

$$\begin{aligned}Z &= P/W \times h/3 = 8000/12474 \times 3.7/3 \\ &= 0.641 \times 1.23 = 0.79 \text{ m}\end{aligned}$$

For no tension condition  $N + Z$  should be less or equal to  $2/3b$

$$N + Z = 0.86 + 0.79 = 1.65 \text{ m}$$

$$2/3 b = 2/3 \times 2.5 = 1.66 \text{ m}$$

As  $N + Z$  is less than  $2/3b$  ( $AF = 1.26m$ ), no tensile stress is likely to develop within any horizontal plain of the structure and hence the structure is safe from tension.

### **b. Safety against over turning**

Over turning moment =  $P \times h/3$

$$= 8000 \times 3.5/3 = 9333 \text{ kg-m}$$

Balancing moment =  $W (b - N) = 12474 (2.5-0.86)$

$$= 20457 \text{ kg-m}$$

As the balancing moment is greater than the overturning moment, the structure is safe from over turning. The factor of safety is  $20457/9333 = 2.2$

### **c. Safety against sliding**

Frictional resistance offered by the base =  $uW$

$$= 0.5 \times 12474$$

$$= 6237 \text{ kg}$$

Horizontal force  $P = 8000 \text{ kg}$

As  $uW$  is less than  $P$ , the structure has a tendency to slide forward. To prevent sliding the structure should be embedded with 0.3 m of footing in the hard strata.

### **d. Safety against crushing**

In order to prevent sinking of the structure at the base, the maximum compressive stress (weight) acting normal to the strata must be less than the permissible compressive stress for the strata at the base.

$$\begin{aligned}
 f_{\max} &= W/b [(1 + 6 e/b)] \\
 &= 12474/2.5 [1 + (6 \times 0.01)/2.5] \\
 &= 4989.6 \times 1.024 = 5109 \text{ kg/sq.m}
 \end{aligned}$$

As,  $f_{\max}$  is less than the bearing capacity of bed soil (25,000 kg/sq.m), the structure is safe against sinking.

## 6.6 INNOVATIVE DESIGNS OF WEIRS

As on date, not only a large number of check dams have already been constructed in our country but more are likely to be constructed in the near future. Any reduction in the construction of cost through improved design parameters and use of low-cost materials will go a long way in making substantial savings.

Overflow weirs are basically retention walls whose stability is achieved by their own weight and buttresses (support) on the downstream side. Innovative design would basically involve reduction in cost by use of cheaper construction material and improvement in design resulting neither an over-design nor unduly risking strength and stability. Over-designing of a weir primarily originates from over-estimation of peak discharge.

Construction of rock-fill dams i.e placement of assorted locally available boulders within a concrete shell could be a low-cost option. Similarly small-thickness R.C.C dykes with buttresses at suitable intervals may be another. The possibilities need to be explored and site-specific designs tried out in the field on an experimental basis.

## ***7.0 Water Requirement of Crops***

---

### **7.1 FUNCTION OF IRRIGATION WATER**

Irrigation is the practice of applying water by artificial means to the soil for sustain plant growth. The function of water is many:

- Water acts as a solvent to dissolve the nutrients which the plants absorb through their roots.
- It replenishes the moisture lost by plants through the process of evapo-transpiration necessary for plant growth.
- It aids in the growth of certain microbes in the soil beneficial to plant growth.
- It provides the necessary cooling effect during the high ambient temperature.
- Extra water is required for preparing the land and raising nursery.
- At times extra water is required to remove excess of salts from the soil through leaching.

Every crop amongst other, requires certain quantity of water during its period of growth. If the rainfall is sufficient and timely then no irrigation is required to raise a crop.

### **7.2 FUNCTION OF RAINFALL**

Plants meet most of their water need from Rainfall. The need for additional water through irrigation is requires only when

- There is no rainfall
- Water available from rain is not adequate .
- Rainfall during the season may be sufficient but its distribution does not coincide with the entire need of the crop.

Although rainfall in India follows a pattern but it is with sufficient deviation to make it unpredictable. Average annual rainfall of the country is 1100 mm which takes place in 130 rainy days. Annual rainfall around Amritsar, Delhi, Jaipur, Chandigarh, Udaipur, Ahmedabad in the west and Aurangabad, Hyderabad, Bangalore, Pune in the central region lies between 400-800 mm. In India, drought is said to have taken place when rainfall of a year is less than 50% of the normal. The situation is described as severe drought when annual rainfall is less than 75% of the normal annual rainfall.

### **7.2.1 Effective Rainfall**

When a particular rainfall incident is very little say to the order of 2-5 mm, it barely moisten the soil and gets evaporated almost immediately. Conversely, in case of concentrated heavy rainfall, major part of water goes away as run off after the soil is fully saturated. Excess water which flows away naturally are not available to crops for their growth. The useful part of the rainfall available in situ for crop production is the Effective Rainfall (ER). It does not include water lost due to surface run off, deep percolation below root zone and the moisture remaining in the soil after harvesting.

Effective rainfall is governed by numerous factors like distribution and Intensity of rainfall, characteristic of soil and crops, land slope, carry over soil moisture, depth to groundwater table, surface inflow and out flows. For estimation of irrigation requirement of crops, the quantum of effective rainfall should be subtracted from the total water requirements. Estimation of effective rainfall is made easily by using standard tables when the mean monthly rainfall and mean monthly consumptive use (pan evaporation data) is available. The estimation methods of these parameters are presented in the later part of this chapter.

## **7.3 CROP SEASONS**

Crops may be seasonal or perennial. The three major crop seasons in India are Kharif, Rabi and Summer. Crops taking more than 12 months to mature are perennial crops. Depending upon the rainfall pattern and crop variety, these seasons may slightly vary from one state to another. Months covering these seasons are:

#### A. In North India

Kharif	:	June – September
Rabi	:	October – March
ZaidKharif	:	March - June
Zaid Rabi (late winter crop)	:	January – April

#### B. In Deccan Area

Kharif (monsoon)	:	Mid June – Mid October
Rabi (Winter)	:	Mid October – Mid February
Summer	:	Mid February – Mid June

In South India Kharif and Rabi seasons are not very distinguishable as the total rain is distributed more or less evenly during these two seasons. It is obvious that summer crops depend completely on irrigation and Rabi crops on part rainfall and part irrigation. Kharif crops take full advantage of rainfall. Kharif crops however requires irrigation when monsoon fails or the rainfall of the area is not conducive for Kharif crops. Water requirement of a particular crop depends among others, upon season (climatic conditions), crop period and their stages of growth. Crop like paddy can be grown in all seasons if irrigation facility is available. Paddy consumes maximum quantity of water not only for its own use but also for preparation of land and nursery.

As Paddy and Wheat are the main crops, the following cropping pattern is common in India which has been evolved over years following primarily the rainfall pattern.

<b>Kharif</b>	<b>Rabi</b>	<b>Summer</b>
Paddy	Wheat/Maize	Pulses
Paddy	Pulses	Paddy
Paddy/maize	Pulses/vegetables	-
Jawar/Bajra	Wheat/vegetables	-

**Table: 7.1 Common crops for different seasons**

Cash crops like sugarcane, cotton, Soyabean, tobacco, jute, oil seeds etc. are taken as per local practices in areas where supplementary irrigation is available.

## **7.4 PRINCIPAL INDIAN CROPS**

### ***Paddy***

Paddy consumes large quantity of water as the field is generally kept submerged for most part of its growth period. In our country, it is grown during all seasons. Clayey-loam to loam soils (heavy soil) are ideal for paddy. The short duration Paddy matures in 85 to 110 days while the relatively long duration variety stands in the field for 100 to 180 days. The paddy varieties in different seasons are known as Aus (March – June), Aman (July – November) and Boro (December – March). About 3 to 5 cm of water is required for seedlings and nursery raising. The nursery takes about 15-21 days to form the seedlings suitable for transplanting.

Puddling and transplantation require another 20-30cm. Total water requirement varies between 185-240 cm depending upon the area and desired depth of submergence. Irrigation water for paddy comes from rainfall supplemented by canal/tank irrigation. Yield of Paddy has been found to vary depending upon its submergence. About 3 -7 cm of submergence throughout the growth period is conducive to higher yield.

The various stages of growth of short duration Paddy after transplantation are initial Tillering (10-20 days), maximum Tillering (20-30 days), Jointing (30-50 days), Boot (50-60) days, Flowering (60-70 days) and Grain development (70-90 days). Direct seeded Paddy has lower yield and also consumes about 30% more water. A recently developed Paddy cultivation practices known as SRI where only one seedling is planted in straight lines with a specified spacing has been found to yield higher quantity of Paddy with relatively less quantity of water.

### **Wheat**

Wheat is grown in quantity next to paddy. Well drained clayey loam, loam and sandy loam soils (light soil) are suitable for growing Wheat. The crop season is normally Oct/Nov to Jan/Feb. About 4 – 9 irrigations are necessary with about

4.5-7.5 cm of water in each application. In Indo-Gangetic plain, wheat is commonly sown on moisture conserved in the soil during the preceding rainy season. There after it requires one to four irrigations. In Bundelkhand and eastern Rajasthan regions wheat is grown on conserved soil moisture supported by one irrigation or two.

Wheat in many regions is also grown in the down stream side of large tanks/reservoirs utilizing the rich soil moisture available without any irrigation at all. The stages of growth are Crown root initiation (20-25 days), Tillering (40-50 days), Jointing ( 55-60 days), Root/flag leaf (70-75days), Flowering (85-90 days), Milk formation (100-105 days), Dough formation (115-120days).

### ***Maize***

Maize can grow throughout the year in favorable climatic conditions in fertile and well drained loamy soil. While Kharif Maize is Rainfed, Maize in other seasons requires irrigation. Normally the crop is sown in first week of July and harvested in early October. Rainfed crop is grown commonly either in hilly regions or in tracts of medium high rainfall where rainfall is from 100 to 115 cm. Irrigated Maize is also grown in tracts where rainfall ranges from 50 to 75 cm per annum. Rainfed Maize needs 3 to 5 irrigations to supplement rainfall. Growing period is 100-120days. The stages of growth are Vegetative state (20-40) days , Tasselling and silking stage (45-60 dys).

### ***Groundnut***

Groundnut is typically a crop grown in the millet and cotton growing regions. In Pujab it grows mainly sandy soil in Ludhiana district mostly under rainfed condition where rainfall is about 12 cm. The protective irrigation requires are about 2 to 3 cm, one of which is given to help uniform maturity of the crop and the other is during water stressed period. In some part of MP, Groundnut is grown as rotation crop mixed with cotton.

In central Karnataka it is grown as a rainfed crops. In Marathawada and Rayalseema regions, it is grown as rotation crop with cotton and Jawar under rainfed conditions by utilizing soil moisture as far as possible.



### ***Cotton***

Cotton needs about 45 cm of water for optimum production of this crop. The irrigated cotton is sown on a pre-soaking field of 10 – 12 cm inches of water. The first irrigation is applied 40 days after sowing and the subsequent one after 25 days. There after the crop receives irrigation every 12 to 15 days unless the intervening rains obviate the need for irrigation. Over 90% of the cotton area in India is irrigated and the seed is sown during the first shower of rain. Normally, under rainfed conditions, short staple cottons are cultivated as their water requirement is slightly less than those of the medium staple cotton.

### ***Jawar***

Jawar is mostly rainfed but some (Rabi Jawar) may be raised under irrigation. It is in fact the premier fodder crop of the country. Water requirement for developing good grains is 45 cm and that for fodder 30 cm. The fodder Jawar in the North and North western India is started with irrigation. It is commonly sown in April – May and harvested in July-August. It requires 12 to 15 acre inches of water the most of the requirement comes from rain. Unirrigated Jawar is raised in the areas where rainfall exceeds 25 to but is less than 40 inches.

### ***Sugarcane***

Total irrigation water requirement of sugarcane is about 120 cm, remaining water comes from rainfall. The duration of the crop in sub-tropical region is nearly 12 months while under tropical conditions it stands in the field from 18 to 24 months. Water requirement is high due to long growing season, particularly where the temperature is high.

### ***Pulses***

There are two main classes of pulses. The winter pulses are Gram, Peas, Khesari, field Bean and Lentil. The other type is summer pulses like Arhar, Mung, Urid, and Guar. Most of these are grown under rainfed condition either during the monsoon season on the conserved soil moisture.

## *Vegetables*

From seasons point of view, vegetables can broadly be divided into two groups namely winter vegetables and summer vegetables. In each season a numerous types of vegetables are grown. The season wise description of common winter vegetable are Cole crop (cabbage, cauliflower), Root crops (Radish, carrot), Bulb crops (Onion), Tuber crops (potato), Leafy vegetables (spinach), Leguminous (peas, beans). Winter Vegetables in general have shallow root system and are sensitive to moisture stress. They normally extract water from the upper 15-30 cm of the soil profile. It is essential for these vegetables to maintain soil moisture level near Field Capacity. The soil moisture at about 15 cm depth should not be allowed to drop below 70% of available moisture. In case of Onion, irrigation should be stopped when plants begin to mature.

Summer Vegetables have moderate to deep root system. They can effectively extract moisture from lower part (60-120 cm) of the root zone even when upper part is near the Wilting Point. Moisture requirement of these crops can be met, if average soil moisture level to the root zone is maintained to 50-80%. For Potato, first irrigation is given after germination is complete. Subsequent irrigations are needed at 10 to 12 days interval.

## *Castor*

Castor is an important oil seed in dry land regions like Andhra Pradesh, Tamilnadu, Saurashtra. In most states it is grown in the field bunds under rainfed conditions. Water requirement of castor is less which is derived from the rainfall alone.

## **7.5 CROP ROTATION**

When the same crop is cultivated in a land from year after year, the fertility of the land goes down and the soil becomes deficient in a particular nutrient favored by this particular crop. In order to restore the productivity and soil structure of the land, it is useful to keep the land fallow for some period. The method of growing different crops one after the other in rotation in the same field is known as crop

rotation. A cash crop may be followed by a fodder crop or Gram which being leguminous crop helps in enhancing Nitrogen in the soil. Crop rotation facilitates extraction of different nutrients from the soil thus preventing typical deficiency of a particular nutrient. Crop rotation also helps in controlling pest attacks specific to a particular crop.

Generally, the following types of crop rotations are recommended depending upon the soil type.

Wheat – Jawar – Gram  
 Rice – Gram  
 Cotton – Wheat – Gram  
 Cotton – Jawar – Gram  
 Wheat – Mustered – Gram

## 7.6 SOIL CHARACTERISTICS

Basically, Soil is a composite mixture of sand, silt, clay and organic matter. It may be divided in to several groups based on their mode of classification (Taxonomy). The criteria of classification include age, occurrence, geological factors, land use capability, chemical composition, structure, texture, chemical reaction etc. Study of soil in terms of its texture and chemical reactions however have more relevance in determining crop water requirements and hence are discussed below.

### 7.6.1 Texture of Soil

Soil texture is determined by the percentage composition of sand, silt, clay and constituent mineral matter of the soil. Sand, Silt and Clay which are determined by their particle sizes occurring in various proportions lead to the broad classification of soil texture as detailed below.

<b>Diameter of particles, mm</b>	<b>Texture of Soil</b>	<b>Sandy Loam, %</b>	<b>Clay Loam, %</b>	<b>Clay, %</b>
2.0 upwards	Gravel	-	-	-
2.0 – 0.2	Coarse sand	65	30	1
0.2 – 0.02	Fine Sand	20	30	9

0.02 – 0.002	Silt	5	20	25
Below 0.002	Clay	10	20	65

**Table 7.2 Broad classification of soil texture**

Amore detailed classification of soil texture is however available (chapter 4) covering all classes like sandy, sandy loam, silty loam, silty clay, loam, sandy loam, clay loam, silty clay, sandy clay and clay . The broad classification presented above however suffices the need of field practitioners.

### 7.6.2 Chemical Composition of Soil

Common soil is a composite mixture consisting of mineral (inorganic matter), organic matter, water and air. The general chemical composition of a standard soil is as follows:

<b>Radicals</b>	<b>Percentage. %</b>
Total Carbon (C )	0.6
Total Nitrogen ( N)	0.06
Total Phosphate (PO <sub>4</sub> )	0.02
Total Potassium (K <sub>2</sub> O)	0.22
Total Lime (CaCO <sub>3</sub> )	0.10
Silica (SiO <sub>2</sub> )	75.0
Iron and Alumina (Fe <sub>2</sub> O <sub>3</sub> + Al <sub>2</sub> O <sub>3</sub> )	15
Moisture	9.0

**Table 7.3 Composition of a representative soil**

The various chemical reactions of soil normally studied in the laboratories for the purpose of crop production are their nutrient contents, pH and Total Dissolved Solid (TDS).The nutrient content studies of soil (soil fertility) are restricted mostly to the availability of three basic elements namely Nitrogen (N), Phosphorus (P) and Potassium (K).

A farmer therefore needs to know the main nutrient constituents in his land in terms of the proportion of N, P, K. Equipped with this information through a soil health card, the farmer knows how much of the three main chemical fertilizers are to be applied in what proportion.

<b>Nutrients</b>	<b>Low kg/ha</b>	<b>Medium Kg/ha</b>	<b>High Kg/Ha</b>
Available Nitrogen (N)	Below 280	280 – 560	Above 560
Available Phosphorous (P)	Below 10	10 – 25	Above 25
Available Potassium (K)	Below 110	110 - 280	Above 280

**Table 7.4 Soil fertility status**

While Urea is applied to add Nitrogen (N) necessary for growth of leaf, Phosphate (PO<sub>4</sub>) is needed for balancing the soil reaction. Murat of Potash (K) facilitates in grain production. Commercially available composite fertilizer usually contains all these three constituents in different proportions.

### 7.6.3 Soil Reactions

The two important parameters studies primarily to understand chemical reaction of the soil are its reaction for pH and Total Dissolved Salts (TDS). pH is measured as log of hydrogen ion concentration with a negative sign. This indicates the degree of acidity or alkalinity of the soil. The scale is taken from 0 – 14. A neutral soil has a pH value equal to 7. A value below 7 indicates the soil is acidic and above 7 indicates it is alkaline. Total Dissolved Salts (TDS) on the other hand controls the acidity due to sodium and other cations. The value of TDS is obtained by measuring its Electrical Conductivity (EC) of soil extract in millimho/cm. The EC value of normal soil is below 1 and abnormal soil is above 4. The rating chart of soil test data is presented below for ready reference.

<b>pH</b>	<b>Remarks</b>	<b>EC, milli- mho/cm</b>	<b>Remarks</b>
Below 7	Acidic	Below 1	Normal
7 – 8.5	Normal to Saline	1 - 2	Critical for Germination
8.5 – 9.0	Tending to become Alkaline	2 - 4	Critical for Growth
Above 9	Alkaline	Above 4	Injurious to most crops

**Table 7.5 Chemical reaction of soil**

## 7.7 SOIL WATER

Subsurface water can broadly be divided in two parts namely the zone of aeration (soil water) and the zone of saturation (Groundwater). This two zones usually merge together at times during rainy season when groundwater receives its recharge but remains separated by a large distance during other months. Soil water is confined to the zone of aeration where both water and air occurs together. Soil water are classified as hygroscopic water, capillary water and gravitational water.

Hygroscopic water is that little amount of water which a dry soil tends to absorb from atmosphere. It is held by the forces of molecular attraction and can be removed only by heating. This water is not available to plants. Capillary water is that water which is retained in the soil by the force of surface tension after draining of the rest of the water from the soil. Capillary water is held in soil pores spaces as a continuous film around the soil particles which can be removed by applying force higher than the capillary force. Part of this capillary water (soil moisture) is available for plant use.

Gravitational water though readily available to plants, normally do not remain within the soil for long. It drains out downwards (percolation) by the force of gravity from the soil under favorable drainage condition. However if the Gravitational water remains in soil for a long period and does not drain out , serious damage may take place to the crops due to lack of Oxygen and accumulation of carbon dioxide in soil. This happens when the soil is said to be water-logged.

Water holding capacity (a function of porosity) of different soils are different. The amount of water retained by coarse sand is around 5% of its dry weight while loamy soil may retain 35% or more . Clay retains still higher quantity which is about 45% of its dry weight.

### **Field capacity**

Field Capacity is also known as moisture equivalent or the water holding Capacity of soil. It is the moisture content that will be held in soil after excess water is drained out by gravity (drainage). When all the pores are completely saturated

with water (capillary water), the Field Capacity is said to be at 100%. When mentioned in groundwater context, Field Capacity is also referred to as Specific Retention.

### **Wilting Point**

It is the moisture content of soil at which plants no longer obtain sufficient moisture to survive . If moisture content goes beyond this level, plants will wither permanently and can not be brought back to life even if water is added afterwards. The amount of moisture left in a soil after a plant has permanently wilted is called the wilting coefficient of the soil or the permanent wilting point. From irrigation point of view, Wilting point in most soil is taken in the region of 50% of the Field Capacity.

### **Available Moisture Content**

The difference in the moisture contents between Field Capacity and Wilting Point is known as Available Moisture Content. It is the moisture content upto the Wilting Point which is useful to the plant. Readily Available Soil Moisture is that portion of the available soil moisture which is most easily extracted by plants. It normally varies between 75-80% of Available Moisture. It may be noted that as the moisture content in soil decreases, the tension with which the water is held in soil increases. Consequently, plants can not extract adequate moisture for their proper growth.

It should be remembered that soil moisture content varies as per the texture of the soil. Heavy soil (clay loam) contains more soil water than light soil (sandy loam). Further, plants can extract soil moisture only from their root zone. Water that moves down below the root zone is not available to plants. The moisture requirement of crops also is not uniform throughout its growth period. They require different level of moisture at their different stages of growth.

It is therefore desirable to monitor the moisture level at the root zone and apply water to raise the soil moisture level from the existing level to its Field Capacity. Soil moisture level usually is not allowed to fall below 50% level to avoid water stress to the plants. As the purpose of irrigation is to prevent lack of moisture

availability to plants, the common practice is to supply water only that much so that the moisture is available to the root zone is raised to the Field Capacity where water occurs at a sufficiently low tension making the moisture most readily available to the plant.

## **7.8 IRRIGATION SCHEDULE**

Irrigation requirement of crops means working out the schedule of application i.e how much water is to be applied at which time from sowing to harvesting. Once the Water Requirement of crops is understood, it becomes an easy task to schedule the application of irrigation water. Field scheduling of irrigation can be arrived at under a few well established practices taking into consideration the Duty of water, Delta requirement, Consumptive Use of crops and Soil Moisture content approaches.

Plants can get their water requirement through a combination of irrigation, effective rainfall (ER) and soil water contribution (SW) in various proportions. Therefore,

$$WR = \text{Effective Rainfall (ER)} + \text{Irrigation Water (IR)} + \text{Available Soil Water (SW)}$$

Or,  $IR = WR - (ER + SW)$

In other words, minimum quantity of Irrigation water required to be added to the plants is equal to Water Requirement (WR) of the crop less effective Rainfall (ER) and available water in the soil (SW).

Factors controlling irrigation requirement therefore depend broadly upon the climatological conditions (for consumptive use), soil conditions (for soil moisture status), crop types and irrigation management practices. A broad treatment of these factors and their sub-factors affecting water requirement of crops production is treated as follows.

### **7.8.1 Factors that Affects Irrigation Requirement**



### ***A. Type of crop***

Different crops require different quantity of water. It is obvious that Irrigation practice for paddy will be entirely different from that of say Gram.

### ***B. Climate and season***

Entire water applied to crop is not available to the crop. Some water gets lost through evaporation, deep percolation. Evaporation and evapo-transpiration on the other hand varies with sun shine hour, temperature and wind velocity. Hence water requirement will vary from season to season and also during different period of the same season.

### ***C. Useful rainfall***

If a major part of the rainfall is available to the crop for its use, then naturally less water will be required to be applied to the crop through Irrigation. More the useful rainfall less will be irrigation requirement.

### ***D. Type of soil***

If the permeability of the soil is high then more water will be lost due to deep percolation. Therefore less water will be required to a clayey loam soil than a sandy loam soil for the same crop.

### ***E. Efficiency of cultivation method***

If the cultivation method (including land preparation and Irrigation) is less efficient entailing various losses like transmission losses, application losses etc. , the need for irrigation water will naturally increase unnecessarily.

### ***F. Source of water***

Quantity of Irrigation water available from canals, Tanks, bore wells and dug wells differ widely. Naturally, the water transmission and application methods vary widely for each of these sources.

## **7.9 APPLICATION OF IRRIGATION WATER**

From water application points of view, Irrigation Methods can broadly be divided in three categories namely surface irrigation, sub-surface irrigation and overhead irrigation. Surface irrigation is the most common practice of irrigation where water is applied to the field by simply by releasing the water in to the plots. This method of irrigation is resorted to when sufficient water is available at a low cost.

In wild flooding method there is very little application control while some controls are feasible in border flooding, check flooding and basin flooding applications. In furrow irrigation method, water is made to flow through suitably sized and spaced furrows from a trunk channel travelling from a higher to a lower elevation across the furrows. Crops are planted in the ridges in between the furrows. In hilly region water can be made to flow from plot to plot which are closely terraced. Excess water is collected by a common drainage channel for disposal.

In sub-surface irrigation water is applied directly below the root zone of the plants/crops. Normally, water is applied to a depth 30-75 cm below ground level. Moisture moves upward by capillary action to meet the requirements at the root zone. Water is applied as drips at a controlled rate through buried pipe system with holes at fixed intervals or by using rubber tubes thus saving a considerable amount of water. Drip irrigation is found more convenient in plantation areas with row crops.

In overhead irrigation, water is applied by sprinkling the same over the crops to simulate the effect of rainfall. Clean silt free water is brought to the crop site through long easy to join light pipes using high pressure pumps. Hydrants (pipes of lower diameter) with rotating sprinklers at the top are attached vertically to the main pipe at desired location. Each sprinkler usually cover an area of about 7 -10 m in diameter. Sprinkler system of irrigation is useful in saving considerable amount of water and also irrigating undulating land uniformly with less labour as in tea plantation area. Initial investment for a commercial sprinkler system is high but can be proved economical in the long run if the crop produced commands a good price.

## **7.10 IRRIGATION EFFICIENCY**

It is the ratio of the actual amount of water available to the crop and the total quantity of water applied for irrigation expressed in percentage i.e total irrigation efficiency is the combined result of both conveyance efficiency and water application efficiency.

$$E_i = (W_c/W_r) \times 100$$

Where

$W_c$  = Irrigation water consumed by crop during its growth period

$W_r$  = Irrigation water supplied at source during the growth period

### **7.10.1 Net Irrigation Requirement**

The amount of irrigation water required to be applied to the root zone depth of the plants so as to bring the soil moisture content back to its field capacity is Net Irrigation Requirement (NIR)

### **7.10.2 Gross Irrigation Requirement**

While applying water to the root zone, certain amount of water is lost during conveyance and application. The gross quantity of water to be supplied at the source to meet the Net Irrigation Requirements of crops taking into account the intervening losses is Gross Irrigation Requirement (GIR).

## **7.11 SOIL MOISTURE APPROACH**

Soil moisture is more readily available to crops when it is well within the root zone at lowest tension i.e at Field Capacity. Moisture content at field capacity is considered 100% available to crop and at 0% at permanent Wilting point. Soil moisture should never be permitted to fall below the permanent Wilting point. The safe limit for soil moisture depletion for various crops have been found from field trials. But for most crops, depletion of soil moisture at root zone is not permitted to fall below 50% from its Field Capacity. Consumption of water by crops are

however not uniform throughout its growth period. There is a specific critical period when the crops consume maximum quantity of water. During this period of peak moisture demand, high moisture level must be maintained for proper growth. The peak period moisture demand is different for different crops. It therefore so transpires that in order to compute water requirement of crops using management of the soil moisture regime, we need to know not only the average available moisture holding capacity of various soils and depth of root zone for common crops but also about average daily peak moisture use.

The interval between one irrigation to the next depends, primarily on the state of soil moisture depletion. Normally a crop has to be irrigated before soil moisture is depleted below 50% of its availability in the root zone. Irrigation intervals are shorter during summer than in winter. Similarly, the intervals are shorter in case of sandy soils than in the case of heavy soils (clayey). When water supply is limited the intervals are made prolonged irrigating the crops only at critical stages.

The soil profile from which plants can extract moisture is controlled by rooting characteristic of the plants. Depth of root zones for normal crops may ranges between 0.5 to 2 m. The normal depth of roots of some matured crops are presented below.

<b>Shallow rooted 60 cm</b>	<b>Moderately deep rooted 90 cm</b>	<b>Deep rooted 120 cm</b>	<b>Very deep rooted 180 cm</b>
Rice	Wheat	Bajra	Citrus
Onion	Tobacco	Jawar	Grape
Cabbage	Groundnut	Cotton	Sunflower
Cauliflower	Chillies	Maize	Coffee
Lettuce	Potato	Sugarcane	Lucerne

**Table 7.6 Depth of root zone of some matured crop**

Most of the feeder roots are located near the upper part of the root zone usually within the top 45 cm. Plants do not extract moisture equally from the entire root zone. The usual extraction pattern is that about 40% of the extracted moisture is

from the top quarter of the root zone, 30% from the second quarter, 20% from the third and 10% from the fourth quarter of the root zone.

Application of water is also decided by the moisture holding capacity of the soil. For example, In sandy and loamy soil water would tend to move down wards beyond the root zone as deep percolation. On the other hand clayey soil will retain such water for a longer period. The average moisture holding capacity for normal soil types are presented below;

<b>Soil Type</b>	<b>Field Capacity %</b>	<b>Permanent Wilting Point %</b>	<b>Bulk Density gm/cc</b>	<b>Available Water per meter Depth of soil profile, cm/M</b>
Sandy	5 – 10	2 – 6	1.5 – 1.8	0.05 – 0.1
Sandy loam	10 – 18	4 -10	1.4 – 1.6	0.09 – 0.16
Loam	18 – 25	8 – 14	1.3 – 1.5	0.14 – 0.22
Clay loam	25 – 32	11 -16	1.3 – 1.4	0.17 – 0.29
Clay	32 - 40	15 - 22	1.2 – 1.4	0.20 – 0.21

**Table 7.7: Moisture content of soil with different texture**

Experienced farmers usually predict soil moisture in their fields by removing a pinch of soil from different depths and rolling the same into a ball between their fingers to ascertain the moisture content based on experience. Soil Moisture meters are used for scientific studies. The simple type of field tensiometer (soil moisture meter) uses a small rectangular Gypsum block ( approx. 2”x 1”x ½”) with electronic circuit embedded within it. The gypsum block is buried into the soil for a certain period of time allowing it to absorb requisite quantity of moisture. The attached meter provides moisture content value in percentage. The other type of Soil Moisture meter uses a thin pointed metal rod no longer than one meter in length as a sensor. The rod is inserted in to the soil to the requisite depth and the attached meter shows the moisture content values.

The net quantity of water to be applied depends on the moisture deficit at the time of irrigation in the root zone. The depth of irrigation applied is greater when irrigation is given at longer intervals. Similarly, the finer the soil texture, the greater is the irrigation applied on account of the lower water holding capacity of

the soil. The deficit ( $d$ ) is estimated from the Field Capacity ( $F_c$ ), the actual soil moisture content at a given time ( $M_c$ ), the bulk density of the soil and the depth of the root zone ( $D$ ) of the crop under consideration. Thus

$$d = (FC - MC) \times A_p \times D / 100$$

Where

$A_p$  = Apparent density of soil

$D$  = Depth of root zone

$F_c$  = Field capacity

$M_c$  = Moisture before irrigation is started

### 7.11.1 Irrigation frequency

Irrigation frequency refers to the number of irrigations applied throughout the crop period. It depends on the consumptive use, and on the available moisture in the root zone between Field capacity and starting moisture level before irrigation. It is a function of both soil and crop. It is important that irrigation period is determined specially during the peak use period. Irrigation period should be kept less or equal to Irrigation frequency. The concept of Irrigation period and frequency is useful in designing the pumping capacity of the Irrigation system like sprinkler and drips.

Design Irrigation frequency =  $(F_c - M_c) / C_{up}$

Where,

$C_{up}$  = Peak period moisture use rate.

Irrigation Period = Net depth of water application / Peak moisture use rate

#### *Problem 1*

Determine the irrigation interval from the given data

Field capacity = 30%

Permanent wilting point = 15%

Apparent density of soil = 1.3

Effective depth of root zone = 120 cm

Daily consumptive use = 1.5 cm

### ***Solution 1***

$$d = (FC - MC) \times Bd \times D / 100$$
$$= [(30 - 15) \times 1.3 \times 1.3] / 100 = 23.4 \text{ cm}$$
$$\text{Irrigation interval} = 23.4 / 1.5 = 15 \text{ days}$$

### ***Problem 2***

Determine Field Capacity (FC) of a soil with the given field data.

Depth of root zone = 1.8 m

Existing Moisture level = 8%

Dry density of soil = 1.45 gr/cc

Quantity of water applied to soil = 650 m<sup>3</sup>

Water lost in evaporation and deep percolation = 10%

Area to be irrigated = 0.1 ha. = 1000 sq. meter

### ***Solution 2***

Quantity of water applied in the field = 650 cubic meter

Water wasted (10%) through evaporation and deep percolation = 65 m<sup>3</sup>

Quantum of water used in raising moisture content to FC = 650 - 65 = 585 m<sup>3</sup>

Depth of water needed to raise moisture content (8%) to FC = 585/1000 = 0.585 m

But depth of water required in root zone to increase moisture content is given by

$$A_p \times D (FC - MC) / A$$

$$\text{Or, } 0.585 = 1.45 \times 1.8 (FC - 0.08) / 0.1$$

$$\text{Or, } FC - 0.08 = 0.224$$

$$FC = 0.224 + 0.08 = 0.304 = 30.4\%$$

### ***Problem 3***

Determine discharge requirement of a pump for the following set of data

Area = 4 ha

Pumping hours = 6 hr

Irrigation efficiency = 70%

Available Moisture content of soil = 1.6 cm/m

Peak rate of moisture use = 0.4 cm

### ***Solution 3***

Irrigation is to be applied at 50% of Available Moisture at root zone.

Net depth of water per application =  $(1.6 \times 50) / 100 = (16 \times 50) / 100 = 8.0 \text{ cm}$

Irrigation Period =  $8.0 / 0.4 = 20 \text{ days}$

Depth of water to be pumped per application (GIR) =  $8.0 / 0.7 = 11.4 \text{ cm}$

Required capacity of the pump =  $(11.4 \times 4) / 20 = 2.28 \text{ ha cm/day}$

=  $(2.28 \times 10000 \times 1000) / (6 \times 60 \times 60 \times 100) = 2280 / 216 = 10.56 \text{ lps}$

### ***Problem 4***

Moisture holding capacity of a Sandy loam soil 140 mm/M between Field Capacity and Permanent Wilting Point. The root depth of the crop is 30 cm and the allowable depletion of moisture is 35%. Daily water use of the crop is 5 mm/day. The area to be irrigated is 15 ha and irrigation efficiency of 60%. Determine a) Allowable depletion depth between two irrigations, b) frequency of irrigation, c) Net application depth of water, d) Volume of water required, e) Time to irrigate 4 ha plot

### ***Solution 4***

a. Moisture holding capacity of root zone =  $140 \times 0.3 = 42 \text{ mm} = 4.2 \text{ cm}$

Allowable depletion between two irrigations =  $35 \times 4.2 = 1.47 \text{ cm}$

b. Frequency of irrigation = Available moisture / Moisture consumed per day  
days =  $1.47 / 0.5 = 2.94 \text{ days}$ . Say 3 days.

Net water to be applied each time =  $3 \times 0.5 = 1.5 \text{ (in place of 1.47 cm)}$

Field irrigation requirement/day = Net Irrigation Requirement / Efficiency =  
 $1.5 / 0.6 = 2.50 \text{ cm}$

c. Total Volume of irrigation requirement =  $2.5 \times 15 = 37.5 \text{ ha cm} = 37.5 \times 10000 / 100 \times 60 \times 60 = 1.05 \text{ lps}$



Working out the irrigation schedule based on soil moisture regime is rather tedious for a common farmer. This requires monitoring soil moisture level at the root zone of the crop almost every day before application of the requisite quantity of water. For this reason, other simpler empirical methods particularly the Delta approach are used to estimate irrigation requirement of crops.

## **7.12 DELTA AND DUTY**

Every crop requires certain amount of water at a fixed interval of time during its period of growth. The amount of water applied each time multiplied by the number of application will be the total amount of water consumed by the crop. The volume of this water applied to a crop is customarily expressed by its depth (Delta) in cm. The concept of Delta or depth of water is similar to the practice of measuring the volume of rainfall in terms of equivalent depth of standing rain water. If the quantity water applied to a field is imagined to stand on the field without percolation and evaporation, the resulting height of the standing water is its depth or Delta. In other words Delta of a crop is the total depth of water applied to the cropped area during the entire crop period. Delta is expressed conveniently in cm.

### **7.12.1 Duty Approach**

The concept of Duty of water is applicable to cropped area under canal irrigation. The capacity to sufficiently irrigate any cropped area by a given quantity of water is the Duty of that water. Duty therefore indicates the irrigation capacity of an unit volume of water. As Water Requirement of crops is not uniform throughout its period of growth, it is customary to express Duty as the extent of cropped area that can be matured by an unit volume of water ( $1 \text{ m}^3 / \text{Sec}$  supplied throughout the Base period of the crop. Base period (B) of a crop is the period for which water is to be supplied to the crop during the crop season. Therefore, if 100 ha of cropped area is irrigated by 0.2 cumec of water supplied throughout (24x7) the Base Period B, the Duty of this irrigation water will be  $100/0.2 = 500 \text{ Ha/cumec}$  for the Base period B. Duty is said to be high when small volume of water irrigates a larger area and vice versa. Duty approach is applied normally to large areas under canal irrigation system. In case of Reservoirs the Duty of water is expressed in hectare

per million cubic meter. For lift schemes, ha per cubic meter per hour can be conveniently used as the unit of water Duty.

In large canal irrigation system, from the source water first move in its main canal; from the main canal it flows into the Branch canal; from the Branch canal, it flows into the Distributaries; from the Distributaries it flows into the Minor, then into the field channel and finally into the fields. A great deal of water is therefore lost from the entire system due to evaporation and infiltration which is referred as Transmission loss.

Let us take a crop (Paddy) of crop of Base period B. Also assume that 1 cumec of water is applied to field for a duration of B days.

The volume of water (V) applied to field during B days is given by

$$V = (1 \times 60 \times 60 \times 24 \times B) \text{ m}^3 = 86400B \text{ m}^3$$

By definition of Duty (D), one cubic meter of water supplied for B days matures D hectare of crop. Therefore

$$\text{Total Depth of water applied (Delta)} = \text{Volume} / \text{Area} = 86400B / 10000D \quad [\text{I ha} \\ = 10000 \text{ sq. meter}]$$

$$= 8.64B / D \text{ meter} = 864B / D \text{ cm}$$

This gives the relationship between Delta and Duty of a crop under canal irrigation.

### ***Problem 5***

Find the delta of a crop when its Duty is 864 ha/cumec and the base Period B is 120 days.

### ***Solution 5***

$$\text{Delta} = 864B / D \text{ where B is in days and D is in ha/cumec}$$

$$\Delta = (864 \times 120) / 864 = 120 \text{ cm}$$

### 7.12.2 Delta Approach

Field practitioners had been working out water requirement of crops based on field experiences over a long period using Delta of water as per the crop, season and soil type. Total Delta has further been divided into irrigation intervals and depth of water to be applied per irrigation over the entire crop period. Agriculture Refinance and Development Corporation (ARDC) in a special report has published Irrigation Requirement of crops (Rabi) for the states of Punjab, Andhra Pradesh, Rajasthan, Uttar Pradesh and Bihar. The Table below presents the general data covering most parts of India.

Crop	Crop Period Days	Total Water Requirements, cm	Number of Irrigations Nos	Irrigation Interval Days	Daily water Requirement, cm	Depth of Irrigation in each interval cm	Pump discharge 6 working hrs. lps/ha
Jawar (Rb)	132	30	4	30	0.29	7.5	1.75
Jawar (Hy)	90	45	6	15	0.50	7.55	3.50
Wheat	120	45	6	20	0.37	7.5	2.62
Gram	90	22	3	30	0.29	7.5	1.75
Onion	150	90	16	9	0.62	5.6	4.35
Potato	132	75	10	12	0.37	7.5	4.37
Banana	365	75	12	10	0.62	6.25	4.37
Maize (Rb)	90	45	6	10	0.75	7.5	5.25
Maize (Hy)	108	67	9	12	0.62	7.5	4.37
Vegetables	120	75	10	12	0.62	7.5	4.37
Chillies	132	90	12	10	0.75	7.5	5.25
Cotton (Kh+Rb)	202	15	2	30	0.29	7.5	1.75
Fodder (Lucern)	150	90	13	10	0.6	6.0	4.20
Leafy Veg.	60	30	6	10	0.5	5.0	3.50
Groundnut	120	75	12	10	0.75	7.5	5.25
Sugarcane	365	108	12	12	0.75	9.0	5.25

**Table 7.8 Irrigation Water Requirement of Crops , Maharashtra, ARDC, Bombay**

As per the Table above, wheat (Rabi) in Maharashtra with 120 days crop period needs application of total 45 cm of water divided in 6 irrigations at 20 days interval, each irrigation of 0.37 cm over 20 days (7.4 cm) water would irrigate 1 ha /day. A with 2.62 lps discharge running for 4 hrs a day would be able to irrigate 1 ha per day.

ARDC has also suggested an empirical method to estimate discharge requirement of a pump by using the following formula:

$$Q = (28 A I)/RT$$

Where,

Q = Required discharge of the pump, lps

A = Cropped area, Ha

I = Depth of each irrigation, cm

R = Rotation of irrigation, days

T = Working period of the pump, hr

### ***Problem 6***

If Wheat requires about 7.5 cm of water after every 20 days and the growing period is 120 days. Find the Delta value of Wheat.

### ***Solution 6***

If the total crop period is 120 days and water is to be applied in every 20 days interval then

Number of watering required =  $120 / 20 = 6$  nos

Depth of water required each time = 7.5 cm

Total depth of water required in 120 days =  $6 \times 7.5 = 45$  cm

Delta of Wheat is 45 cm.

### ***Problem 7***

Compute discharge requirement of a pump operating for 8 hrs/day to irrigate the following crops of a) Wheat = 4 ha, b) Vegetables = 2 ha and c) Fodder = 1 ha, using the Delta Table above.

### ***Solution 7***

From the Table

Wheat

Area = 4 ha

Irrigation interval :20 days

Depth of each water: 7.5 cm

Vegetables

Area = 2 ha

Irrigation interval : 12 days

Depth of each water: 7.5 cm

Fodder

Area = 1 ha

Irrigation interval :10 days

Depth of each water: 6cm

Area that can be irrigated per day with the above schedule are

Wheat :  $4/20 = 0.20$  ha / day

Vegetables:  $2/12 = 0.17$  ha / day

Fodder :  $1/10 = 0.1$  ha / day

Quantity of water required

Wheat :  $0.20 \times 7.5 = 1.50$  ha-cm

Vegetables :  $0.17 \times 7.5 = 1.28$ ha-cm

Fodder:  $0.10 \times 6 = 0.6$  ha-cm

Total = 3.38 ha-cm/day

Required discharge capacity of the pump =  $(3.38 \times 10000) / (8 \times 60 \times 60 \times 100) =$

$3.38/288 = 0.02$ cumec

= 20 lps

Note: 1 ha = 10000 m<sup>2</sup> ; 1 m = 100 cm; 8 hrs = 8 x 60 x60 seconds

### **Problem 8**

Compute discharge requirement of a pump operating for 8 hrs/day to irrigate the following crops Table above of a) Wheat = 4 ha, b) Vegetables = 2 ha and c) Fodder = 1 ha, using the ARDC Empirical Formula.

### **Solution 8**

We have  $Q = (28 A I)/RT$

From the Table

Wheat:	I = 7.5cm	R = 20 days
Vegetables :	I = 7.5 cm	R = 12 days
Fodder:	I = 6.0 cm	R =10 days

$$Q_{\text{wheat}} = (28 \times 4 \times 7.5) / (20 \times 8) = 840 / 160 = 5.25 \text{ lps}$$

$$Q_{\text{Vegetables}} = (28 \times 2 \times 7.5) / (12 \times 8) = 420 / 96 = 4.38 \text{ lps}$$

$$Q_{\text{Fodder}} = (28 \times 1 \times 6.0) / (10 \times 8) = 168 / 80 = 2.10 \text{ lps}$$

$$\text{Total discharge required} = 5.25 + 4.38 + 2.10 = 11.73 \text{ lps}$$

### **7.13 CONSUMPTIVE USE**

Consumptive use of a particular crop is the total amount of water used by plant in Transpiration (for building plant tissues etc.) and Evaporation from adjacent soil and from plant foliage at any given time. Consumptive use is therefore taken equal to Evapotranspiration. The value of  $C_u$  is different for different crops and may be different even for the same crop at different locations and time. Value of  $C_u$  over the entire crop period are then used to determine irrigation requirement of the crop.

If there is a decrease in Evaporation, Transpiration increases correspondingly. Temperature, humidity, wind condition and incoming solar radiation are some of the climatological factors that affect  $C_u$  considerably. There is also a close relationship between sunshine hours and  $C_u$ . Evaporation data is generally obtained from USWB Class A Pan Eaporameter. The value of total Evaporation is then converted to ET values by multiplying evaporation data with corresponding crop factor. If there are no such stations close to the cropped area, then  $C_u$  can be computed by using Blaney-Criddle formula. The advantage of using Blaney-

Criddle formula is lies in the fact that the requisite data is readily available in our country and the application is relatively easy for field practitioners.

It was observed by Blaney-Criddle that  $C_u$  of growing crops is closely related to mean monthly temperature and day light hour. The relationship is given by

$$C_u = K_f = K_{tp}/100 = u$$

Where,

$K$  = Monthly crop coefficient

$t$  = Mean monthly temperature, degree Fahrenheit

$p$  = Monthly daylight hours expressed as percentage of daylighthour of the year

$u$  = Monthly consumptive use, inches

The value of coefficient  $k$  for use in Blaney-Criddle is presented in Table 7.9 and the values of monthly percentage of the daylight hour ( $p$ ) for the year at different latitudes are presented in Table 7.10. Temperature in (Fahrenheit) values are available from records of local meteorological stations. With the known values of the above parameters, the monthly Consumptive use ( $C_u$ ) can be computed from Blaney-Criddle equation. Monthly  $C_u$  multiplied with crop period gives the seasonal  $C_u$ . In metric system, the formula is given as

$$C_u = K [p (0.46t + 8.13)]$$

Consumptive use of crops is not uniform. It varies throughout the season, month and even day at a given location. Daily transpiration is lowest just before the sun rise which reaches to maximum shortly before noon. Consumptive use is low at the start of growing season, increases as plant foliage develops and day become longer and warmer It generally reaches a peak during fruiting period and then rapidly declines to the end of the growing season.

The average daily water use rate of the highest Consumptive use of the season which occurs for a few days (6 – 10 days) is called peak period use rate. This is the design rate to be used while scheduling for irrigation water. In shallow soils or with soils with low water holding capacity or for plants with shallow root system , the peak use period ranges from 3 – 6 days. The peak use period for plants with

moderately deep root system growing in deep soils with good water holding capacity may range from 8 – 15 days.

Months	Rice	Wheat	Maize	Sugarcane
January	-	0.50	-	0.75
February	-	0.70	-	0.80
March	-	0.75	-	0.85
April	0.85	0.7	0.5	0.85
May	1.0	-	0.6	0.90
June	1.15	-	0.7	0.95
July	1.3	-	0.8	1.0
August	1.25	-	0.8	1.0
September	1.10	-	0.6	0.95
October	0.9	0.70	0.5	0.90
November	-	0.65	-	0.85
December	-	0.60	-	0.75

**Table 7.9 Monthly crop coefficient (K) for use in Blaney-Criddle formula**

Latitude N	Jan	Feb	Mar	Apr	May	Jun	Jul	Aug	Sep	Oct	Nov	Dec
8	8.13	7.41	8.45	8.39	8.75	8.51	8.77	8.70	8.25	8.31	7.89	8.11
10	8.11	7.40	8.44	8.43	8.81	8.57	8.84	8.74	8.26	8.29	7.89	8.08
12	8.08	7.40	8.44	8.43	8.84	8.64	8.90	8.78	8.27	8.28	7.85	8.05
14	7.98	7.39	8.43	8.44	8.90	8.73	8.99	8.79	8.28	8.28	7.85	8.04
16	7.94	7.30	8.42	8.45	8.98	8.89	9.07	8.80	8.28	8.24	7.72	7.90
18	7.88	7.26	8.40	8.46	9.06	8.99	9.20	8.81	8.29	8.24	7.67	7.89
20	7.73	7.26	8.20	8.52	9.14	9.22	9.25	8.95	8.30	8.19	7.58	7.88
22	7.76	7.22	8.41	8.57	9.22	9.12	9.31	9.00	8.30	8.13	7.50	7.56
24	7.58	7.17	8.40	8.60	9.30	9.13	9.41	9.05	8.31	8.10	7.43	7.46
26	7.49	7.12	8.40	8.64	9.37	9.30	9.49	9.10	8.32	8.06	7.36	7.35
28	7.40	7.02	8.39	8.68	9.46	9.38	9.58	9.56	8.32	8.02	7.27	7.27
30	7.30	7.03	8.38	8.72	9.53	9.49	9.67	9.22	8.34	7.99	7.19	7.14
32	7.20	9.67	8.37	8.72	9.63	9.60	9.77	9.28	8.34	7.93	7.11	7.05
34	7.10	6.91	8.36	8.8	9.72	9.70	9.88	9.33	8.36	7.90	7.02	6.92
36	6.99	6.86	8.35	8.85	9.31	9.83	9.99	9.40	8.36	7.85	6.92	6.79

**Table 7.10 Monthly percentage of daylight hours for latitude 8° to 36° covering India**



### **Problem 9**

Compute the Consumptive use (Cu) of sugarcane crop at Ahmednagar district (18° N) using Blaney – Criddle formula.

### **Solution 9**

<b>Month</b>	<b>Mean monthly temperature, °F</b>	<b>Monthly crop coefficient k from Table 7.9</b>	<b>Percentage day light hour P Table 7.10</b>	<b>Monthly consumptive use , inches Cu = Ktp/100</b>
January	70.43	0.75	7.88	4.16
February	73.58	0.80	7.26	4.27
March	79.61	0.85	8.40	5.68
April	84.65	0.85	8.46	6.06
May	85.82	0.90	9.06	6.99
June	81.41	0.95	8.99	6.95
July	76.82	1.00	9.20	7.06
August	76.28	1.00	8.81	6.72
September	77.00	0.95	8.29	6.06
October	77.99	0.90	8.24	5.78
November	73.22	0.85	7.67	4.77
December	69.89	0.75	7.89	4.13
			Total annual	= 68.65 inches

### **Problem 10**

The required climatological data for Wheat crop in Karnataka is presented below. Determine Cu of the crop and also the irrigation requirement assuming 80% efficiency. A crop factor of 0.8 may be taken for use of Blaney-Criddle formula.

<b>Month</b>	<b>Average monthly temperature in °C (5 years average)</b>	<b>Monthly % of Sunshine hour (From Table)</b>	<b>Average useful Rainfall, cm</b>
November	18.0	7.20	1.70
December	15.0	7.15	1.42
January	13.5	7.30	3.01
February	14.5	7.10	2.25

### **Solution 10**

Using the above data the value  $f = p(1.8t+32)/40$  has been calculated in the Table below.

Month	Average monthly temperature in °C (5 years average)	Monthly % of Sunshine hour (From Table)	Average useful Rainfall, cm	$f = p(1.8t+32)/40$
November	18.0	7.20	1.70	11.6
December	15.0	7.15	1.42	10.5
January	13.5	7.30	3.01	10.3
February	14.5	7.10	2.25	10.3
Total			8.38 cm	42.7

$$C_u = k \cdot f = 0.8 \times 42.7 = 34.16$$

$$\text{Irrigation Requirement} = C_u - R_e = 34.16 - 8.38 = 24.34 \text{ cm}$$

$$\text{Gross Irrigation Requirement} = \text{Net Irrigation Requirement} / 0.8 = 24.34 / 0.8 = 30.43 \text{ cm}$$

#### **7.13.1 Relation between Evaporation and Evapo-transpiration**

Attempts have been made in the field by using standard class A pan evaporimeter to estimate evapo-transpiration of crops. The general relation is

$$ET = K \cdot E \cdot P$$

Many research stations are now equipped with Eaporameter and has worked out the crop coefficient k for obtaining  $C_u$  value for crops grown in the region.

% of crop growing season	Wheat Ludhiana	Wheat Pune	Cotton Pune	Maize Ludhiana	Vegetables
0	0.14	0.30	0.22	0.40	0.25
5	0.17	0.40	0.22	0.42	0.28
10	0.23	0.51	0.23	0.47	0.30
15	0.33	0.62	0.24	0.54	0.38
20	0.45	0.73	0.26	0.63	0.45

25	0.60	0.84	0.35	0.75	0.50
30	0.72	0.92	0.58	0.885	0.55
35	0.81	0.96	0.80	0.96	0.58
40	0.88	1.11	0.95	1.04	0.60
45	0.90	1.1	1.03	1.07	0.63
50	0.91	1.0	1.08	1.09	0.65
55	0.90	0.91	1.08	1.1	0.65
60	0.89	0.80	1.07	1.11	0.65
65	0.86	0.65	1.05	1.1	0.63
70	0.83	0.51	1.0	1.07	0.60
75	0.80	0.40	0.93	1.04	0.58
80	0.76	0.40	0.85	1.0	0.55
85	0.71	0.20	0.73	0.97	0.50
90	0.65	0.12	0.62	0.89	0.45
95	0.58	0.10	0.50	0.81	0.38
100	0.51	0.10	0.40	0.70	0.30

**Table 7.11: Crop coefficient k for different growth period of crops to be multiplied with Pan Evaporation data to obtain Cu for a few Indian crops**

Coefficient k to be multiplied with Class a Pan Evaporimeter data to obtain Consumptive use (ET). Total moisture content in a soil depends upon its depth and water holding capacity . The finer the texture , greater is its water holding capacity. These properties govern the depth and interval of irrigation.

#### **7.14 ESTIMATION OF EFFECTIVE RAINFALL (ER)**

##### Method – I

In arid and semi arid region rainfall is normally light and soil moisture level is low. A good amount of space is therefore available to the soil profile to hold water supplied from external source. Effective rainfall in such areas therefore is relatively high. In humid and heavy rainfall area where soil is already saturated with moisture, the effective rainfall would be low. The percentage of effective rainfall decreases with respect to the monthly rainfall decreases with respect to the monthly rainfall by decrement in the following order taking 5 consecutive dry years as base.

Monthly rainfall, mm	25	50	75	100	125	150	>150
Effective rainfall, %	90	85	75	50	30	10	0

**Table 7.12 Percentage of Effective Rainfall corresponding to Rainfall**

Monthly Effective Rainfall is not adequate for working out a better water scheduling practice. Attempts have therefore been made to compute daily effective rainfall values through a variety of approaches.

Following method as described by Dastane is used to estimate Effective Rainfall

### **Rainfro Equation**

Rainfro suggested the following equation

$$ER = E R_g + A$$

Where

ER = Effective Rainfall

R<sub>g</sub> = Growing season Rainfall

A = Average Irrigation Application

E = Ratio of Cu to Rainfall during the growing season (obtained from the Table)

<b>Cu/Rg</b>	<b>E</b>	<b>Cu/Rg</b>	<b>E</b>	<b>Cu/Rg</b>	<b>E</b>
0	0.00	1.6	0.57	3.5	0.84
0.2	0.10	1.8	0.61	4.0	0.88
0.4	0.19	2.0	0.65	4.5	0.91
0.6	0.27	2.2	0.69	5.0	0.93
0.8	0.35	2.4	0.72	6.0	0.96
1.0	0.41	2.6	0.75	7.0	0.98
1.2	0.47	2.8	0.77	9.0	0.99
1.4	0.52	3.0	0.80	-	-

**Table 7.13 Ratio of Cu to Rainfall during the growing season**

**Problem 11**

Given

Consumptive use = 40 cm

Growing season Rainfall = 50 cm

Average irrigation application = 20 cm

Compute Effective Rainfall.

**Solution 11**

$$C_u / R_g = 40/50 = 0.8$$

E (from Table) for C/R<sub>g</sub> = 0.8, Given value of E = 0.35

$$ER = E R_g + A = 0.35 \times 50 + 20 = 17.50 + 20 = 37.5 \text{ cm}$$

Cu	50	100	150	200	250	300	350
Monthly Rainfall	Normal Monthly Effective Rainfall, mm						
25	17	18	20	22	25	25	25
50	33	36	40	44	50	50	50
75	47	54	58	65	74	75	75
100	50	69	75	83	95	100	100
125		83	91	102	116	125	125
150		97	106	126	136	150	150
175		100	120	136	154	172	175
200			131	148	169	191	200
225			142	162	189	210	225
250			148	175	206	226	245
275			150	188	223	242	265
300				195	235	258	288
325				199	242	275	304
350				200	245	285	320
375					248	292	328
400					250	296	335
425						298	340

450						300	343
475							346
500							349
525	50	100	150	200	250	300	350

**Table 7.14 Normal monthly effective rainfall as related to normal monthly rainfall and average monthly consumptive use.**

If normal monthly rainfall is 200 and Average Monthly Consumptive use is 150 mm, then the effective rainfall is 131 mm.

## 8. *Afforestation in Watersheds*

---

### 8.1 FOREST AND AGRICULTURE

Although India has nearly 15% of the world population, it has only 1.8% of its forests. Per capita availability of forest in 1981 was estimated to be 0.11 ha. This is likely to become about 0.07 ha by the year 2001. Following Stockholm Convention, India adopted the policy of maintaining 33% of its geographical area under forest cover. In 1950-51, India's forest cover as per official records was estimated as 39.94 mha (12.2%). In 1980-81 the same was reported to have increased to nearly to 75.18 m ha (22.8%).

A separate study on the existing forest cover was conducted using satellite imagery for the periods 1972-75 and 1980-82. The study estimated that forest cover in 1972-75 was of the order of 55.52 mha (16.88%) and the same for 1980 - 82 was 46.35 mha (14.10%), a reduction of 9.17 mha (16.5%) in 7 years. The figure was, however, revised by Forest survey of India and for the corresponding period (1982), the forest cover was estimated as 64.80 mha, an increase of about 9.28 mha . In 1995 ,in its sixth report in the series, the State of forest reserve has been estimated (MoEF,1998-99) as 63.34 mha, i.e 19.27 % of the geographic area of India. While the dense forest (crown density more than 40%) and open forest (crown density between 10%-40%) occupy about 11% and 8% of the geographical area respectively, mangroves occupy 0.15% of the geographical area.

Both crops and forest are essential for the survival of mankind. On one hand we need to grow more food by bringing more lands under agriculture and on the other grow more forests to meet our needs for timber and non-timber forest produce (NTFP). It is a matter of debate as to how much of India's lands should be used for agriculture and how much for forest. According to her commitments in Stockholm convention, India has pledged to develop 33% of her surface area under forest cover.

There is no dispute that agriculture and forest must go hand in hand, and one should not be viewed in isolation from the other. In the past, the common land use dictum was that of forest in forest lands and crops in arable lands. However, consequent to an increase in conservation forestry, fuel, fodder and timber have become scarcer. As a result, afforestation activities are making in-roads not only on common lands but also on agricultural lands. The concepts of social forestry, farm forestry, silvipasture etc. are some of the examples. In other words, in the near future, the arable and the wastelands will have to generate all our food, fuel, fodder and timber requirements.

The private and village common lands in the upper reaches of many watersheds are usually degraded to various degree due to soil erosion. Attempts by any community to work out a living from such lands through conventional agriculture is likely to be only partly successful. It is, however, possible to produce enough income from these lands and yet protect them from soil erosion through silvipasture, horticulture and agro-forestry. Protection of upper reaches is essential so that the agriculture in the downstream area can flourish. At times, a proper crop mix in the upper reaches can even generate a higher income than possible through conventional agriculture in the lower reaches.

In addition to the forest land which are owned and are managed by the forest department, an urgent need for undertaking large-scale plantation in the wastelands and common lands has also been felt by others throughout the country. Adoption of watershed management practices will not only help in reducing the biotic interferences on the forest lands but will also encourage plantation in both private and common wastelands.

## **8.2 UTILITY OF FOREST**

A natural forest is not just a cluster of trees. It is an eco-system by itself which supports a host of biotic lives, within and outside the system. Forest provides multiple benefits to mankind. Some of the important ones are:

- Forests controls soil erosion.
- Forests retards run-off and release it slowly through the existing streams over longer period.



- Forests yield an extensive range of products useful to us. Major among these are timber, fuel and fodder. They also provide a host of other minor produce like animals, leaves, fruits, seeds, roots, barks, herbs, resins, flowers etc. in sufficient quantities which are used as food, liquor, smoke, oil, medicine, fertilizer, dye, flavouring agents and raw materials for other income-generating activities.
- Forests harbour wildlife essential for maintaining ecological balance in nature.
- Trees play an important role in controlling favourably the micro-climate and absorbing carbon dioxide which is harmful to environment and producing oxygen beneficial to all life forms.
- Forests have aesthetic value and provide recreational facilities.

### **8.3 CLASSIFICATION OF FORESTS**

Forests in our country have been classified into the following categories depending upon their legal status, density of cover, functional role and climatic factors.

#### **8.3.1 Based on Legal Status**

Reserved forest (40.18 mha)

Protected forest (21.73 mha)

Unclassed forest (13.27 mha)

In a reserved forest, all activity by outsiders is prohibited except those specifically permitted; in a protected forest all activities are permitted except those specifically prohibited. Unclassed forests are those village forests occupying mostly the revenue lands which have traditionally controlled access to the village communities and are usually subject to full-scale exploitation. However, in some rare cases, village forests, particularly those associated with religious sentiments are maintained by the local community in an exemplary state of preservation.

#### **8.3.2 Based on Density of Cover**

Dense forest (36.14 mha)  
Open forest (27.66 mha)  
Mangroves (0.4 mha)

Dense forests are those where the forest cover has a crown density of 40% and above. Dense forest contain trees, bushes and shrubs rising to three levels or tiers. Open forest consists of trees and bushes having crown density varying from 10-40 %. Mangroves (littoral or swamp forest) are typical medium-height forests growing naturally in swampy lands along sea coast and delta regions.

### **8.3.3 Based on Functional Role**

Protection forest ( 10mha)  
Production forest ( 16mha)  
Wild life sanctuaries (13 mha)  
Social forest ( 25mha)

While a protection forest aims to conserve tress, shrubs, animals, soil, water etc., a production forest is maintained to yield timber and other forest produce. National parks and wild life sanctuaries are specially demarcated and managed forests where the primary aim is to protect and breed endangered animal species. Social forests aim to meet the need of local communities for fuel, fodder, fibre, fruits, small timbers etc.

### **8.3.4 Based on Climatological Factors**

Tropical (52.0 mha)  
Sub Tropical and Temperate (5.77 mha)  
Montane (4.57 mha)  
Alpine (1.86 mha)

These have further been subdivided into wet, moist and dry on the basis of rainfall, number of rainy days and humidity.

### **8.3.5 Based on Other Criteria**

Depending upon the thrust area, plantation projects have also been categorized

under various project titles. The projects initiated in the early 80's, involving plantation in common wastelands for the benefit of local communities, are known as social forestry projects. The implications of other terms like bund plantation, roadside plantation etc. are obvious. The concept of involving communities in the protection and management of forests in the forest lands further led to the adoption of terms like Joint Forest Management (JFM), Participatory Forest Management (PFM) etc. Some of the project titles, however, are not commensurate to the actual outcome of the projects.

#### **8.4 DEFORESTATION**

Deforestation is a global phenomenon and India has its own share of it. Causes of deforestation have been widely discussed. Major causes of large-scale deforestation are:

Increasing demand for timber and fuel wood  
Increasing pressure from grazing animals  
Diversion of forest lands for non-forest use  
Insufficient management practices

The phenomenon of deforestation beyond a critical level has such far-reaching consequences that it may not be currently possible to anticipate full implications for the future. Some of the direct consequences are easy to perceive but the indirect ones which will be set off as a *chain reaction* are beyond immediate comprehension.

The direct and clearly apprehensible consequences of large scale deforestation are:

- A sharp decline in the availability of timber, fuel, fodder and loss of wildlife.
- Large-scale soil erosion and rapid siltation of storage reservoirs.
- An increase in the incidence of flood and drought in the same region during monsoon and summer seasons respectively, irrespective of any appreciable change in the rainfall pattern.
- Loss of organic matter leading to use of more non-organic fertilizer, causing increased pollution of land and water.

- Loss of biodiversity which may never be restored.
- The forests act as sinks for CO<sub>2</sub>, a major greenhouse gas causing global warming, which is likely to cause large-scale flooding of the continents.

## **8.5 WASTELANDS**

Wastelands are degraded, unutilized or under-utilized lands which can be put into good use if proper efforts are made. These may be forest, non-forest, private or public lands. There are some differences of opinion about the definition of wastelands. Accordingly, the extent of wastelands in India is variously estimated to be between 45-150 mha, depending upon the definition of the term wasteland adopted for this purpose.

Wastelands fall under one or combination of the following categories of lands:

Degraded forest lands

Over-grazed common lands

Lands along railway lines, roads, between buildings etc.

Saline, alkaline, waterlogged, ravine and marginal agricultural lands

Abandoned mining areas

Sand dunes, cold deserts etc.

From the land-use point of view, wastelands are considered suitable for afforestation. According to a recent report based on satellite imagery, lands showing actual signs of physical degradation extends to nearly 45 million hectare (mha). According to another estimate (Malhotra et al.,1988), nearly 150 mha of lands fall under the category of wastelands. Out of this, nearly 40 mha is believed to be degraded forest land, 35 mha is privately owned wasteland and remaining 75 mha is with the revenue department which require additional attention for their improvement.

## **8.6 AFFORESTATION**

While afforestation refers to establishment of trees on lands which did not have any, reforestation would mean establishment of trees on lands recently cleared of trees (forest land). Silviculture on the other hand implies the management practice,

i.e the methods by which tree crops are raised, harvested and regenerated.

The major component of afforestation activity will, therefore, be the plantation of new seedlings while reforestation is possible through the process of natural regeneration. In an ideal situation, unless there are severe soil erosion and high biotic interferences, forest lands can be restored through the process of natural regeneration by allowing the root stock, already present in the land to grow, by providing adequate protection. But biotic interferences, i.e the pressure on forest from man and animals, are ever increasing and must be dealt with by creating alternatives. The very fact that forest degradation continues unabated, is an indication that natural regeneration alone is unable to cope with the pressure and artificial planting is necessary to reverse the trend.

While reforestation of the forest lands must take into account the revival of the natural bio-diversity, afforestation should be undertaken keeping the needs of the local people in mind. It is believed that plantation of selected tree species in both the upper reaches and near other marginal lands can generate as much income, if not more, from the conventional crops grown in such lands.

## **8.7 CHOICE OF SPECIES**

The choice of species becomes the single most important decision in all afforestation projects. While a natural forest serves a number of functions, an afforested cluster can at best serve a few. For selection of the right species, each of the following questions needs to be answered:

What is the purpose of the intended plantation?

Which of the species are reliable for this purpose?

How long will it take to start harvesting the intended produce?

Who will have the right to use it and how will this be organized?

Which species are potentially available for plantation?

What other plants will grow in the site available?

Although trees have multiple uses, each species of tree has a very specific primary utility for which it is selected. The secondary utility may be kept in mind but in many cases, this may be of only marginal value. For example, a timber species will

seldom yield good fruit, fodder or fibre; a fast growing fuel-fodder species may not be a very good timber; eucalyptus raised for pulp may not be used for fuel, fodder and timber at all. In addition, removal of one kind of produce from a tree may adversely affect production of another, e.g removal of green sal leaves for making plate, reduces the production of sal seeds, slows down growth of wood and increases the chances of damage from pest attacks.

It is, therefore, not justified to expect a particular tree to yield fuel, fodder, fruit, fibre, fertilizer and finally timber in equal abundance. For this reason, it is advisable that while selecting a species only its primary utility be considered so that creation of a sense of over expectation may be avoided.

Another important consideration is the preference of the land owner or the beneficiaries who will use the plants. For example, preference for industrial plantation for pulp and small timber trees need not be overtly justified as a social forestry programme. Similarly, development of Silvipasture for the sake of conservation should clearly define its purpose and permit cutting and carrying away of fodder only to a limited extent.

### **8.7.1 Indigenous Species**

The initial choice should be from indigenous species. Exotics can be tried as a second option, only if, no suitable native species is available for that specific purpose. Some of the reasons for giving preference to indigenous species are:

- They are adapted to the local environment and are part of the ecological system.
- They are less prone to large-scale attack by diseases and pests since controlling agents are already present locally.
- Even mono-culture of indigenous species is more ecologically viable than mixed exotic species for the purpose of conservation of natural flora and fauna.
- The use of timber and other produces are already known to the local users.

### **8.7.2 Exotic Species**

While planting exotic species, the following aspects should be kept in mind:

- They offer much wider choice of species from all over the world.
- An exotic species, away from its natural habitat, is often free from pests and diseases at least in the first rotation since pathogens may not find the alien a suitable host. The absence of natural predators and controlling agents, at a later stage, may render exotic mono-culture susceptible to massive uncontrolled attacks of pests.
- Use of exotics does not necessarily lead to success. Only few species of pines, eucalyptus and acacia are successful world-wide, e.g *Pinus caribaea*, *E. grandis*, *Tectona grandis*.
- Large-scale introduction of exotic species without adequate precautions may cause as many environmental problems as are solved.

### 8.7.3 Rating of Species

Options for selection of the desired tree species are normally influenced by agro-climatic conditions, land capability class, availability of the species of choice and availability of source of irrigation. It is, however, advisable to select more than one species in a proper mix. Monoculture on a large-scale creates some of its own environmental problems. In order to facilitate the choice of species, the relative ratings of some common dryland tree species in terms of their utilities are presented (Hocking, 1993) in Table 8.1. In this table, the rating 1 means least suitable and 10 means most suitable.

Tree Species	Fodder	Fuel	Timber	Growth rate	Erosion control
<i>Acacia albida</i>	8	7	7	6	5
<i>Acacia auriculiformis</i>	2	6	2	7	8
<i>Acacia ferruginea</i>	6	6	4	4	5
<i>Acacia leucocephala</i>	6	5	5	4	4
<i>Acacia nilotica</i>	7	10	8	6	5
<i>Acacia senegal</i>	5	7	6	3	4
<i>Acacia Seyal</i>	7	5	4	8	6

<i>Acacia tortolois</i>	5	7	8	7	6
<i>Azadirachta indica</i>	6	5	6	6	4
<i>Casuarina equisetifolia</i>	3	6	6	7	8
<i>Dalbergia sissoo</i>	3	5	10	6	2
<i>Dendrocalamus strictus</i>	7	2	5	8	7
<i>Dichrostachys cineraria</i>	6	4	3	6	10
<i>Ficus religiosa</i>	7	4	4	8	6
<i>Hardwickia binnata</i>	9	8	8	6	5
<i>Leaucaene leucocephala</i>	10	8	7	10	7
<i>Moringa oleifera</i>	7	2	2	10	1
<i>Pongamia pinnata</i>	6	7	4	6	5
<i>Prosopis cineraria</i>	10	8	8	3	4
<i>Prosopis juliflora</i>	5	9	8	9	8
<i>Sesbania grandiflora</i>	8	3	3	10	5
<i>Tamarindus Indica</i>	8	8	9	2	2
<i>Tecomella undulata</i>	3	5	10	6	5
<i>Terminalia arjuna</i>	4	6	8	7	4
<i>Zizyphus nummularia</i>	6	4	4	5	3

**Table 8.1 Rating of trees for various uses.** Source : Hockings

## 8.8 PROPAGATION BY SEEDS

Most plants can be propagated through seeds. Reproduction of plants using other vegetative parts such as roots, shoots, stems, leaves etc. are known as vegetative propagation.

### 8.8.1 Seed requirements

Collection, extraction and storage of quality seeds of high provenance add to costs. Cost of seeds could be quite substantial when the requirement is very large. For this reason it is helpful to calculate the quantity of seed needed and to store it well in advance. The following formula is used for this purpose:

$$W = (A \times D)/(S \times N)$$



Where,

W = Weight of total seed requirement, kg

A = size of the planting area, ha

D = Intended number of seedlings to be planted per ha

S = Expected survival percentage of the plants and need to fill the gap

N = Estimated number of plantable seedlings that will germinate per kg of seeds

The value of N can be found out as follows

$$N = n \times G \times P \times (1 - M)$$

where,

n = Number of seeds per kg

G = Germination percentage

P = Purity percentage, i.e proportion of seed with other impurities like chaff, husk, stone etc.

M = Estimate of seedling mortality in nursery

G, P and n are normally assessed at source, at the seed centres. Seedling mortality in nursery (M) may be due to poor seed quality, damage in despatch, pests, poor germination, poor management etc. and a value is taken based on past experiences.

### ***Problem 8.1***

*Calculate seed requirements in kilogram for plantation of Subabul plants in 80 ha wasteland with 1090 plants per hectare. The expected survival rate is 70%. The average number of seeds per kg is 3000.*

### ***Solution 8.1***

*From the germination test in the nursery, it was found that the seed has 5% impurities and that its average germination rate is 80%. A 10% mortality rate due to handling is common.*

*The estimated number of plantable seedlings that will germinate per kg of seed (N) is given by*

$$\begin{aligned} N &= n \times G \times P \times (1-M) = 3000 \times 0.8 \times (1.0 - 0.05) \times (1.0 - 0.1) \\ &= 3000 \times 0.8 \times 0.95 \times 0.9 = 2052 \end{aligned}$$

*Add 30% for gap filling*

$$N = 2052 + 616 = 2668$$

*Seed requirement (W) is given by*

$$\begin{aligned} W &= (A \times D)/(S \times N) = (80 \times 1090)/(0.7 \times 2668) \\ &= 87200/1868 = 47 \text{ kg} \end{aligned}$$

### **8.8.2 Collection of seeds**

Good quality seeds will give good quality plants. Normal-sized full and plum seeds germinate best. Seeds which are light in weight are poor in quality and should not be used for propagation. Good seeds are segregated by immersing them in water. While the heavier ones settle at the bottom the defective ones float and should be removed.

Collection of seeds should be made carefully, keeping the following guidelines in mind:

- Seeds should be collected only from the well grown, healthy trees. Very old and very young trees should be avoided.
- Only ripe seeds, fruits or pods should be collected.
- Seeds should be collected from an area which has a similar agro-climatic condition to that of the intended region of planting.
- As a rule, first and last crop of seeds are avoided and only those which ripen in the middle of the season are preferred.
- Seeds should be thoroughly cleaned after collection and stored in gunny bags. The storing place should be free from excessive heat and damp, pests

and insects. Seeds need oxygen and hence gunny bags are quite appropriate. Seeds when handled on a large scale are also stored in sealed metal containers for convenience.

- Each pack of seeds should have the name of the tree, variety, date and place of collection written on the bag. Also the average number of seeds per 1 kg or 100 gr should be recorded in the packet itself.
- As a rule, seeds should be planted as early as possible after collection. The longer they are stored, the more they lose their viability.

Time for seed collection, sowing time and expected percentage of germination of some common tree species are presented in the Table 8.2.

Species	Time for seed collection	Sowing time	Germination percentage
<b>Fuel, Fodder, Timber species</b>			
Arjun	Feb-May	Jul	-
Babul	Apr-Jun	Jun-Jul	50
Sirish	Dec-Jan	May-Jul	60
Mahua	Jun-Jul	Jun-Jul	-
Neem	Jun-Jul	Jun-Jul	70
Shisam	Nov-Jan	Jun-Jul	45
Su Babul	Oct-Dec	Jun-Jul	50
P. Juliflora	May-Jun	May-Jun	90
<b>Fruit Trees</b>			
Amla	Nov-Feb	Jul	40
Bael	Apr-Jun	Jun-Jul	-
Ber	Oct-Mar	Jun-Jul	-
Imli	Feb-Apr	Apr-Jul	60
Jamun	Jun-Aug	Jun-Aug	80
Mango	Jun-Jul	Jun-Jul	85
Jack fruit	Jun-Jul	Jun-Jul	85

**Table 8.2 Time for seed collection and sowing time of some common tree species**

### 8.8.3 Seed treatments

The aim of seed treatment is to soften the outer coat of the seed so that moisture can enter the seed easily and germination is made easier. Seeds need moisture and heat to germinate. After the seeds come in contact with soil, they soften and swell under favourable conditions. This may take a few weeks to a few months and sometimes the seed may not germinate at all. Since, in the afforestation programme, it is not desirable to wait for the natural process of germination to occur, pre-treatment of seeds is done to facilitate early germination.

**A. *Cold water treatment***

In this method seeds are kept immersed in cold water for about 24 hours. Water seeps through the seed coat and facilitate early germination. Soaking in cold water overnight is considered adequate for proper germination. Seeds of fruit trees are normally not given any special treatment.

**B. *Hot water treatment***

In this method, seeds are poured into hot water at 80-90 ° C and which is then allowed to cool. Seeds, must not be boiled. The seeds are removed from the water after 24 hours. The treatment also helps killing the pathogens that may be present with the seeds. Seeds of Subabul, Bhimal etc. require hot water treatment.

**C. *Acid treatment***

In acid treatment, seeds are treated with sulfuric acid of low concentration for about 15 minutes. They are then taken out and washed thoroughly with clean water. Acid treatment is administered only to seeds having very hard coating, e.g Babul, Ber, ProsopisJuliflora. Care should be taken to ascertain the concentration of acid and the soaking period so that the kernel of the seed is not damaged.

**D. *Fruit rotting***

Some seeds cannot be separated easily from their fruit, e.g, Arjun, Pomegranate, Fig. The fruit of such seeds are kept immersed in water till the fruit start rotting. The rotten fruits are then mixed with soil containing sand and farm yard manure

and spread on a soil bed till the seeds start germinating.

### **E. *Cowdung treatment***

Certain special types of seeds, e.g teak seeds, are usually soaked in a pit with fresh cowdung and water. They are taken out after two weeks and spread on a soil bed for germination. If necessary, soaking in the cowdung is repeated. Germination normally takes place slowly and, after a week or so, the seedlings are planted in a nursery bed.

### **8.8.4 Germination test**

Before a seed from a particular lot is used for large-scale propagation, it is advisable to conduct a germination test. A germination test is all the more necessary when the seeds are obtained from outside sources. A hundred seeds are drawn at random from the supply and are sown in a germination bed. Information like name of species, place of collection, date of sowing, number of seeds germinated and number of seeds per 100 gr is noted. The germinated seedlings are counted every day and the number of healthy seedlings are totalled after the germination period is over. Germination rate is then expressed in percentage. Based on the weight of 100 seeds, the quantity of seeds required for nursery can be determined after providing a necessary safety of margin.

### **8.8.5 Sowing of seeds**

Seeds can be planted in the field directly or can be raised in a nursery and then planted out. Direct plantation of seeds in the field is relatively easy, less time consuming and requires less planting cost. Direct broadcasting of seeds is feasible with only very vigorously growing grass and plants, e.g. *prosopisjuliflora*. Most other seeds are planted in a in rows forming a strip. A plantation area under direct planting requires intensive protection, supervision and management. The seeds may not get the moisture and heat necessary for their germination. Seeds are also subject to attack from birds and pests. Coating the seeds with lead oxide can prevent such attacks. Seeds should also not be planted very deep. As a rule, soil cover over the seed should be equal to its diameter.

During the seedling stage plants require utmost care and protection which should be provided under field condition. Young seedlings have to struggle against unfavourable weather conditions, biotic factors and weed competition. The result of direct plantation for these reasons may not be very satisfactory. It is, therefore, recommended that seedlings are first grown in a nursery under proper care until they are strong enough to be planted in the fields. Species whose seeds are in short supply and those which are not very hardy should necessarily be raised in a nursery prior to plantation. However, certain species, e.g Eucalyptus spp., can also be raised easily by direct planting in the field.

## **8.9 VEGETATIVE PROPAGATION**

### **8.9.1 Use of Roots**

Suckers, bulbs, rhizomes, tubers etc. are used to propagate plants. Suckers are plant parts which arise from the base of the mother plant along the leaf axis. These are removed with their roots attached and planted directly in the field, e.g pineapple, banana. In the case of bulbs, a strand of leaves remain attached with each bulb. These are separated and planted to get new plants, e.g onion, garlic, lilies. Rhizomes are a kind of stem growing in a horizontal direction within the soil. These have the same structure as that of the plants themselves, i.e stem, nodes and inter nodes. Rhizomes can be cut into pieces with at least one node per piece and planted for propagation, e.g ginger, turmeric, banana. Tuber is a short, thick underground stem. The eyes of the tuber are modified buds. Pieces of tuber with at least one eye can be used for propagation, e.g potato, yam. Root tubers differ from stem tubers to the extent that they do not have organized buds on them, e.g sweet potato. Roots can also be cut into pieces of 10 -20 cm length which are usually planted horizontally, e.g guava, apple, pear etc.

### **8.9.2 Use of stems**

Many plants can be propagated by cutting off a part of the stem and planting it in the soil to a depth of 10-20 cm, e.g morenga, rose, pomegranate, fig, grape. The top cut portion may be sealed by capping it with a handful of cowdung mixed with soil to facilitate survival. Stems used for cutting should be about one to two years old, half inch in diameter and 20-30 cm in length. Leaves of some ornamental

plants can also be cut and planted for propagation, e.g money plant.

### **8.9.3 Layering**

Layering or *Kalam* is the development of roots on a branch while it is still attached to the mother plant. Various stem treatments are possible to stimulate growth of root formation in the stem. After roots are grown in the stem, it is cut and planted. For plants having flexible branches which are close to the ground, ground layering is common. In this method, the middle portion of a branch is kept buried in the soil to 5-15 cm depth. When roots are formed the branch is cut away from the mother plant and planted in the nursery, e.g blackberry, lemon, cherry etc.

Trees which have branches far above the ground and are not very flexible can be propagated through air layering. In this method a one to two year old branch is selected. A strip or a ring of 0.5-1.5 cm length of the bark is removed, using a sharp knife. After winding a string around the cut portion, the area is packed with moist moss and well-decomposed sawdust mixed with common pot soil. The mixture is then wrapped in a polythene sheet and the loose end of the polythene tied tightly with string. Root formation begins in 45-60 days. The branch with the rooted part is detached by cutting and planted for propagation. Fruit trees like litchi, mango, lime, sapota and various other trees are propagated by this method.

### **8.9.4 Grafting**

Grafting involves the union of two plant parts. One part which provides the root system for the grafted plant is root stock. The other, smaller, part which is removed from another plant and is attached to the root stock for growth is known as the *scion*. The root stock should be healthy, vigorous, young and adaptable to the climate and soil. The scion should be taken from a good variety of tree which is to be propagated. The scion wood should have a healthy and swollen bud ready to grow. This is generally collected from the topmost portion of an actively growing branch of the donor plant.

In grafting, a freshly cut scion is placed over the stock in such a manner that the cellular layer between wood and its inner bark of both scion and stock come into intimate contact. The shape of the cutting in the scion and that in the stock are to

be made in such a way that they fairly match with each other leaving no cut portion exposed. The joint is then tied firmly with polythene so as to make it air and water proof. The scion in course of time fuses with and becomes an integral part of the root stock.

*Budding* is another form of grafting in which the scion is only one mature bud portion along with the bark which is inserted in the main tree (root stock) between the nodes. Both the scion and root stock should be about 1 cm in diameter for successful budding.

## **8.10 NURSERY FOR PLANTS**

A nursery is a place where young plants are grown from seeds, cuttings, graftings and by budding. It is in the nursery that ideal soil and moisture conditions can be created to raise healthy plants free from any interference and competition. An ideal nursery site should have good soil for nursery beds, shade trees, irrigation and drainage facilities, space for pathways, a compost pit, a watchman's house, a store room etc.

The size of the nursery area depends on the number of plants to be raised, their species and period up to which they have to be nursed. The area needed for these purposes must be increased further by about 50% for providing space for roads, pathways, irrigation channels etc. From an economic viability point of view, a nursery should raise a minimum of 25000 plants at a time. Normally, the size of a nursery corresponds to about 0.5% of the area to be planted.

### **8.10.1 Preparation of soil**

The nursery area is first cleared of all stones, bushes, roots and herbs. Standing trees should not be felled as they can provide shade. For a standard layout, the area is then levelled and divided into blocks of 11 m x 10 m separated by pathways about 1.8 m wide. Each block, is then divided into beds 10 m x 1 m in size separated by 1 m wide paths. Thus each block will have 6 beds separated by 5 paths, each 1 m in width. The length of the beds could be increased or decreased as per the layout of the land but it is recommended that the width of the beds should necessarily be restricted to 1 m only, so that the middle portion of the bed can be



reached easily from either side.

The beds are dug deep down to 0.3-0.5 m and all roots, gravel and other materials occurring in them are removed. The dug out soil should be kept aside for about a fortnight for weathering. The soil should be broken to get uniform sized soil particles. An appropriate quantity of sand and farm yard manure is added to the soil to make it a well-manured sandy loam. Neem seed powder can also be added to the soil if attack by pests is feared. The soil is then filled back to complete the nursery beds.

### **8.10.2 Type of nursery beds**

A nursery is divided into a number of parts with beds required for different stages of growth and ages of plants. Specially prepared beds for germination of the seeds are germination beds. These beds are normally raised to about 30 cm above ground to ensure proper drainage. Germination beds need not be very deep and do not require any fertilizer.

Sowing is done in lines, seed to seed distance depends on the size of the seed and varies from 0.2-10 cm. The gap between line should be 10 cm. Smaller seeds are sown closely while the bigger ones are sown with wider spacing. Usually the thickness of soil cover over the seed should be equal to the diameter of the seed. Light watering should be given after sowing to keep the soil moist as per need till germination is over.

Beds used to raise seedlings from germination stage up to 5 - 6 leaf stage are known as seedling beds. Germinated seeds are transplanted to the seedling bed at about 10 cm distance. Seedling beds should be well manured. It is possible to have a combined germination bed and seedling bed by planting seeds 10-15 cm apart. However, since there is a possibility of losing space due to failure in germination, the germination bed is kept small and only the vigorously germinating seeds are transferred to the seedling bed.

When the seedlings grow to the 5-6 leaf stage, they are removed from the seedling bed and transferred in the transplantation bed at a distance of 30 cm apart. Transplanted seedlings can remain in the transplantation bed for 6-24 months.

Saplings developed from budding and grafting should remain in the nursery for a minimum of two years and should be planted about 45-60 cm apart in the transplantation bed to avoid use of a second transplantation bed.

Availability of polythene bags, however, has revolutionized nursery practices. Germinated seeds can now be directly planted into polythene bags filled with well prepared soil. A few circular holes are punched at the lower portion of the polythene bags, prior to filling of the soil. These holes permit extra water, if any, to drain out from the soil bag. Soil should be filled in polythene bags 3 - 4 weeks in advance so that any weed that may grow in the bag can be eliminated. Plants can easily be kept in these bags placed side by side over a polythene sheet for more than a year. If plants are to be kept longer it is necessary to transfer them in a larger and thicker bag along with the mud ball around the root from the previous bag and some extra soil mixed with compost (1:1).

## **8.11 PLANTATION OF SEEDLINGS**

### **8.11.1 Plantation site**

Tree plantation is a long-term activity and requires adequate advance planning. The area where plantation is to be done should be prepared well in advance. Plantation of seedlings is done in pits with a pre-decided spacing. The size of the pits will depend upon the nature of the soil and type of the plants. Deeper the pits, higher is the chance of survival of the plants in poor soil. Pit sizes in very poor, poor and good soil should be 90 x 90 x 90 cm, 60 x 60 x 60 cm and 45 x 45 x 45 cm respectively. In waterlogged areas, instead of pits trees are planted on soil mounds 60-90 cm in height.

While digging, care should be taken to keep the topsoil on one side and the bottom soil at another. Dug-out pits are allowed to weather for two to three months. After weathering, the pit is filled up to 2/3 - 3/4 depth with topsoil mixed with FYM, DAP and BHC. If the soil is highly acidic or alkaline, the necessary amount of calcium carbonate or gypsum may be added. In order to lighten the labour involved, the pits should be dug during winter when the soil is sufficiently soft. On hills with high slope where irrigation facility is not available, instead of pits, trenches of 3.5 m length, 60 cm width and 45 cm depth are dug out along the contour lines,

placing the dug out soil in the form of a ridge on the down slope side. Seedlings are planted in the ridge, keeping close to the pit. Sometimes a smaller additional pit may be placed in between the two main pits.

Several combinations of shape and size of pit and ridge are possible. For effective utilization of run-off, the trenches are dug out in rows along the contour lines at suitable intervals in a staggered formation so that a trench and a gap occur alternately in each row. Each trench harvests the run-off from the surface area available between two trenches in the alternate rows. Each seedling is to be planted at a site where it can easily use the soil moisture from the rainwater harvested in the pit and at the same time remain free from any danger of getting damaged due to localized water accumulation.

### **8.11.2 Season of plantation**

In general, trees are planted in the beginning of the rainy season so that the seedlings can take advantage of the entire rainy season. If the area receives high rainfall and chances of water logging exist, plantation may be done in the middle of the rainy season. Plantation of some hill species of fruit trees, however, is done during the winter season. It is always better to plant on a cloudy day.

Seedlings are graded by measuring their stem diameter at the mouth of the poly-bag. Healthy seedlings, about one year old, are transported to the field and stored under a shade. Utmost care should be taken while transporting the seedlings to prevent damage to them. About 20 % extra seedlings should be carried to the plantation site to make good any transportation loss.

Selected seedlings are planted in the pits already prepared for this purpose. The polythene bag is removed and in case any coiling of the root is noticed the plant should be rejected. The plant is then lowered into the pit in such a way that nearly one third of the length of the seedling, along with the root covered with the mud ball around it, remains within the soil. The seedling is held vertical while filling the earth. Care should be taken to compress the soil around the seedling so that it will stand firm and upright. Soil should be made into a heap around the plant to provide proper drainage. If the plant is slender and drooping, a stick should be placed close to the plant to provide support.

### 8.11.3 Planting system and spacing

While planting trees, there may be a tendency to plant them as close as possible so that maximum number of trees per unit area is obtained. When trees are planted too close, the roots get entangled and plants compete with each other for nutrition. Also, lack of sufficient light and air may hinder plant growth. For optimum growth of the trees there has to be optimum spacing. Plant to plant spacing is decided depending upon the kind of trees, size at maturity, diameter of the canopy, soil condition, climate and space required for inter-cultural operations. Branches of fully grown trees should not overlap. The expected diameter of the canopy or the crown growth, therefore, decides directly the spacing between trees. Under favourable soil and climatic condition trees grow full to size and hence land lost by larger spacing is somewhat compensated.

Type of trees	Recommended spacing, m	Type of tree	Recommended spacing, m
Apple	8 -9	Papaya	3-4
Banana	6-8	Peach	6-8
Ber	11-12	Pineapple	1-2
Cashew nut	7-8	Pomegranate	5-6
Custard apple	5-6	Santra	6-8
Det palm	11-12	Sapota	8-10
Guava	6-8	Walnut	10-12
Jackfruit	10-12	Bamboo	10-12
Jamun	10-12	Fuel trees	1-2
Kagzi lime	5-6	manure trees	2-4
Lemon	5-6	small timber trees	
Litchi	10-12	a. till 5-8 years	1-2
Mango	10-12	b. till 8-15 years	2-4
Mulberry	6-8	c. above 15 years	4-8

**Table 8.3 Recommended spacing for some common fruit trees**

From the spacing of plantation point of view, trees can be planted in a number of geometric arrays for easy computation of their numbers as well as for inter-cultural

operations. Thus, in a square system, the plantation area is divided into square grids and trees are planted at the corner of each square. In the square system plant to plant distance is equal to row to row distance. In the rectangular system row to row distance is larger than plant to plant distance. The diagonal system is similar to the square system except that an additional tree is planted in the centre of each square. In this system the number of trees is almost double that of the square system of planting. The central tree is usually not a permanent one and is used to get additional income till the main trees come into bearing. In a hexagonal system trees are planted at the corners of equilateral triangles, i.e plants in each row are staggered in such a way that row to row distance becomes 0.86 times less than the plant to plant distance. Recommended spacing for some common fruit trees is listed in Table 8.3.

## **8.12 POST PLANTATION CARE**

Plants are living beings. They breath, eat and reproduce. After plantation of seedlings, they have to be protected for at least 5 years till they are properly established. Protection is to be given from all kinds of physical damage from both external and internal sources. The most common external damaging agents are human interference and stray animals, both domestic and wild. Protecting plants from human damage, whether intentional or unintentional, is perhaps the most challenging task. This cannot be assured by enforcement alone. The success of the entire plantation programme is hinged on this factor. For this reason it is essential that the local population be involved in the programme in some form or other. Adequate incentive and motivation must be devised so that the local people not only refrain from themselves damaging the plantations but also prevent others from doing so. Organizing a village protection committee assumes special importance, in this context.

### **8.12.1 Fencing**

Entry of stray animals into the plantation area must be prevented at any cost. This can be done by providing suitable fencing or what is commonly referred as cattle-proof trench (CPT). Fencing must be very effective, else many years of growth can be spoiled by stray animals in few hours. Choice of fencing is made on the basis of cost, availability of local labour, time available for raising the fence and

level of effectiveness of protection. Normally fencing of the plantation area should be completed at least one year prior to the plantation so that any breach developed immediately after its construction due to local pressure can be mended and corrective measures enforced.

#### **A. *Barbed wire fencing***

Barbed-wire fencing is raised by enclosing the plantation area in a fence consisting of four strand barbed wires slung on wooden, concrete, stone or iron posts placed about 3 m apart, to a height of about 1.5 m. Such fences are most effective against stray animals particularly when the area cannot be supervised regularly. They are relatively easy to raise and can be erected within a short period. Barbed wire fencing is relatively expensive and the local population can neither be involved in nor do they derive any benefit out of such activity. Moreover, any break at any part of the fencing, if not attended promptly reduces their effectiveness drastically.

#### **B. *Pit or trench fencing***

Pit or trench fencing is constructed by digging a trench with minimum top width 1.2 m, base width of 1 m and depth of about 90 cm, all around the area of plantation. The dug out soil is heaped up in the shape of a ridge at the inner side of the trench at a distance of about 15 cm from the edge. Thorny plants can be planted on the ridge to make the area nearly impregnable to all animals. Trench fencing requires plenty of time to construct and should be done at least one year in advance of the actual period of planting.

The cost of pit fencing may become as high as that of barbed wire fencing specially in area where labour is scarce and the soil is rocky. Pit fencing is preferred over barbed wire fencing in situations where advance planning has been done. Moreover, the deployment of the local population in digging the trench not only gives them additional income but also plays an important role in the process of involving them in the afforestation project.

#### **C. *Stone wall fencing***

These are vertical walls 1-1.5 m in height and 1 m in thickness raised by using

loose boulders all around the area selected for plantation. Stone wall fencing is raised in areas where hard rock is exposed to the ground or soil depth is very shallow, rendering digging a difficult task. Stone wall fencing cannot withstand biotic pressure for too long and needs constant maintenance. Sometimes, mud walls may be raised in place of stone walls or even stone walls may be coated with mud.

#### **D. *Live fencing***

Live fencing or hedges are created by planting along the boundary, trees and bushes not browsed by cattle. This type of fencing may be effective when plantation is done close to habitation where the pressure from stray cattle is under control. Live fencing is common in private lands where such fencing has been raised over the years. Live fencing may also be a source of green manure but requires occasional attention, particularly for filling gaps.

#### **E. *Social fencing***

All the above types of fencing will work only if the local communities cooperate. Plantation activities should therefore not only ensure the support of these local communities, which are traditionally dependent on the forest for fuel and fodder but also try to involve them in the afforestation activities as far as possible. Alternative arrangements for the supply of fuel and fodder must be made for those who had been traditionally using the land demarcated for plantation. A strong commitment to protect the plantation by the majority of the communities, prevent the minority from causing damage to the plantation. This protective approach, using social pressure, is commonly referred to as social fencing.

### **8.12.2 Irrigation**

The survival rate of plants depends largely upon timely supply of water to the seedlings. As a general practice, planting of seedlings is planned for the onset of the monsoon so that their water requirements could be met from the rainfall and stored soil moisture alone. If the monsoon is a good one, the plants thrive. For this reason it is important to construct proper pits and adopt water conservation measures. The choice of species, therefore, gets severely restricted in areas where a

source of supplementary irrigation is not readily available.

It has been demonstrated at several locations that application of one or two critical irrigations in the early years lead to high survival rates and wider species selection. Such irrigations may be provided using pot irrigation, soil injectors, back pack application and even drips and sprinklers. Water may be carried to and stored at site using tractors, bullock carts and even by pumping from a nearby source created for this purpose. It is, therefore, customary that in a watershed development project, a surface water reservoir is created first, prior to undertaking the plantation activities. If the monsoon fails, it would still be possible to save the seedlings by applying at least the life-saving irrigation.

### **8.12.3 Weeding**

Weeds grow faster than seedlings. They can inhibit other plant growth if they are not removed in time. Chemical weeding using weedicide may be suitable for a large area under plantation. Weeding in small areas has to be done manually using one's hands or simple hand implements like hoes. For proper growth, weeding has to be done around each plant twice in the first year and there after at least once for the next two years.

### **8.12.4 Other precautions**

Seedlings can be damaged by a number of agents like diseases, termites, rats, pests, fire etc. Precautions against these should be more preventive than curative in nature. For example, if an area is known to be generally infested with termites, the soil in each pit should be mixed with *BHC* powder (10%) or *Aldrin* right at the preparatory stage. During the first few months each plant should, therefore, be visited regularly, at once in every week. Necessary care should be provided to each plant.

## **8.13 COMMON CAUSES FOR POOR SURVIVAL**

The need for restoring the forest cover in the country is well understood in all quarters. The afforestation efforts undertaken in this direction over the past decade have generated limited results and a great deal of insights about the difficulties



associated with the task. The common causes for poor survival are usually attributed to the following.

- Plantation is not done properly.
- Selection of species incompatible to both soil and climatic conditions.
- Moisture stress met by the plants due to shortage of rainfall following the year of plantation.
- Inadequate post plantation care.
- Grazing and browsing due to poor protection and awareness.
- Malicious damage due to rivalry between village groups.

In order to increase the survival rate, large-scale plantation of fast-growing, drought-resistant, non-browsable species, e.g *Eucalliptus*, *Prosopisjuliflora* etc. is being advocated. This approach not only restricts the choice of species, reducing the biodiversity, but also defeats one of the most important purposes of afforestation, i.e production of fodder. Total livestock population in India is about 452 million, at least half of them feed on forest and common lands. Unless the quality of the livestock population is substantially improved and the practice of stall feeding is vigorously enforced, large-scale afforestation of the common lands in the country will remain an impossible task. Moreover, it should be borne in mind that the choice of species, their use and the package of practices, as applicable to plantation in private lands, common lands and forest lands are altogether different. Strict protection through vigilance and sufficient post plantation care for at least 5 years are essential to make any plantation project successful.

#### **8.14 STANDARD PLANTATION PRACTICES**

Based on the experience gathered both at the demonstration plots in the research institutes and their field applications, the extension scientists have developed a set of standard recommendations covering packages of practices for various type of plantation activities. Although these packages of practices are region specific, they have sufficient common parameters. Two useful package of practices namely the Agro-forestry and the Silviculture packages are discussed below.

### 8.14.1 Agro-forestry package

Agro-forestry is the practice of growing both crops and trees in a suitable mix as per the climate, land capability and owner's preference, so as to maximize the returns from a given land.

Types of lands suitable for agro-forestry are:

- Lands without any source of irrigation and the crop is prone to failure due to erratic rainfall.
- Marginal lands owned by small and marginal farmers associated with subsistence farming.
- Class III and IV wastelands with major limitations of slope and soil depth for viable agriculture.

Common agro-forestry models are:

#### **A** *Bund Plantation*

Contour or peripheral bunds are constructed first to ensure retention of rain water in the field and availability of moisture to the crops in the kharif season with suitable outlets such as pipe outlets.

Multipurpose trees either for fuel, fodder or for organic manure are planted on the field bunds with 1 m spacing (150/ha). Direct seeding of thorny species like *Acacia nilotica*, *Acacia catechu*, *Prosopis juliflora* or non browsable species such as sesam, palas, simul, custard apple can also be done, which would serve as a life fence against grazing. Improved agronomical practices such as contour ploughing and ridge and furrow irrigation are followed to retain maximum possible soil moisture. Mixed cropping of cereals with non-cereal kharif crops could be cultivated which are capable of withstanding a short dry spell and provide good yield with assured moisture retention.

#### **B.** *Strip Plantation*

Growing of trees and crops in alternate strips is known as strip plantation. Narrow

strips (2 m) of multipurpose fuel, fodder and fruit trees and wide strips (15 m) for crop plantation are laid down in alternate sequence. The strips are called contour strips when they are made to follow the contour lines. Fuel, fodder and fruit trees planted in the narrow strips should be lopped periodically to restrict their height so as to avoid shade effects on crops. Strips should be aligned, as far as possible, along the east-west direction to allow sunlight to reach the crops grown in the strips in between.

### **C. *Farm Forestry with Farm pit model***

Fields are first divided into smaller plots along the slope at 10 m intervals. Pits 2.5 m x 1.5 m x 1 m in size (125/ha) are dug in the lowest portion of the plots and the excavated earth is used for bunding the downstream side. Plantation of long-duration trees made around the pits (250/ha). The rest of the bunds are put under grasses and other fodder shrubs which could be lopped periodically and maintained as hedgerows. The rest of the land is used for suitable crops.

The pits have multipurpose functions such as:

- Providing additional soil moisture by harvesting additional rain water.
- Harvesting the silt and nutrient eroded from other parts of the plots.
- Functioning as a compost pit for organic manure.

#### **8.14.2 Silvipasture Package**

Silvipasture is the practice of growing both trees and grasses in the same land for supply of fuel, fodder and timber. Silvipasture is preferred for the following categories of land:

- All classes of common lands.
- Class IV and above wastelands extending to more than 2 ha and belonging to farming families with dairy as their major occupation.

The common approach is to construct a cattle proof trench all around the plot to prevent entry of animals. The plantation practices must be fine-tuned as per the

slope of the land. The recommended measures for lands upto 3% slope, are to construct contour bunds or peripheral bunds and plant trees or fodder shrubs on bunds with 2 m spacing and grass in the rest of the plots.

The recommended measures for lands with 3-8% slope are to divide the land in plots with bunds at 10 m intervals. Pits (450/ha) are dug out at the lowest end of each plot in which water and silt of the plot are harvested. The soils from the pits are used to raise bunds at the downstream side. Trees are planted on the pits and the rest of the lands are used for growing grasses.

In lands with slope above 8%, staggered contour trenches to the extent of 200-300 trenches per hectare ( $L=3$  m,  $tw=0.6$  m,  $bw=0.45$  m) are constructed. Plantation near the trenches and seed dribbling on the berm of the trenches are done. The rest of the area is broadcasted with mixed seed of perennial or seasonal grasses, e.g *Dinanath*, *Stylosantheshamata* etc. If the soil is rocky, instead of trenches, staggered vertical stone walls (3 m x 1 m x 1 m) are raised. Plantation is done in the soil deposited at the upstream side.

## **8.15 JOINT FOREST MANAGEMENT**

In post-independence India, forest management policy was basically the legacy of British Raj, which considered forests primarily a source of revenue and supply of timber for industries. Local communities were the encroachers and the forest resources needed to be protected against their encroachments. While nationalization of Minor Forest Products, now known as the Non Timber Forest Produce (NTFP) generated revenue, the socio-economic system of the tribal communities living within the forest area and depending upon forest produce suffered major setbacks. The forest area, however, continued to shrink, despite the adoption of a control regime. Concerned by the continuing degradation and shrinkage of the forest lands, the Forest Conservation Act, enacted in 1980, banned diversion of any forest land to non-forestry purposes.

Doubts started rising in many quarters whether protection of the existing forests in the country is possible merely by blaming the local communities for exploitation of the forests and adopting strategies for effectively keeping them away from the forest lands. The idea that the tribal and local communities should be closely

associated in protection, regeneration and development of forests started taking shape and a search for a new policy began. The early attempts to involve communities in plantation of trees gained momentum in the 80's, leading to the adoption of the concept known as *Social Forestry*. Social forestry had two components, namely, farm forestry and community forestry with an emphasis on plantation in community and private wastelands, including roadside plantation. This shift in focus, however, did not help in the management of forest lands in any way.

Influenced by the experiences gathered from some pilot projects and the well-known *Arabari experiment* in West Bengal, the basic philosophy of forest management underwent a significant change. The attitude of considering local communities encroachers and hence keeping them away from forests through enforcement measures was replaced by the concept of using local people in protecting the forests. The new policy led to preparation of June 1, 1990 guideline by the Government of India. This guideline laid down the principles governing people's participation in management of forests, which is the precursor of present day concept of *Joint Forest Management (JFM)*. Joint forest management started with a strategy of incentives, in which the forest departments were to mobilize the local village communities for protecting the plantation in forest lands under a joint management programme. The villagers would be allowed a share of the usufruct and a part of the final products in lieu of their services, provided they guaranteed forest protection.

At present, the state Joint Forest Management resolutions assure participating villagers free access to specified Non Timber Forest Produces (NTFPs) and a 25-50% share of pole/timber on final harvesting. In return, the villagers are expected to protect the forest through an organization called *village forest protection committee*, conforming to the structure and procedure specified by the forest department under a forest officer as the member secretary. It also emphasizes participatory planning and implementation as well as integrating concerns for gender and equity, in order to promote decentralized forest management.

### **8.15.1 Emerging issues in JFM**

Some considers JFM, “a learning process for the Forest Department and the

villagers”. To others “JFM is still a constantly evolving process”. No doubt JFM at present is at a cross-road needing direction. Certain doubts and disappointments have already been expressed questioning the very basic rationale of the programme (Sarin, 1996). The disappointments of the members of the village protection committees in associating with the programme are different from those of the staff members from forest departments. The emerging issues pertaining to Joint Forest Management that require serious reviewing are discussed below.

### *Unequal partnership*

The entire approach of mobilizing community participation is unequal, top-down and entrenched in hierarchy. The rights and responsibilities of village forest protection committees and forest department have been specified in the guidelines in such a manner that the village committees have been given most responsibilities and the forest department all the authority. The current relationship between the department and the communities are no different than that of a landlord and a share-cropper. The effectiveness of the entire programme in the future will depend upon to what extent this relationship is expanded to an equal partnership.

### *Undue emphasis on community participation*

The basic premises of JFM is confined primarily to a contractual or a collaborative partnership with the village forest protection committee, wherein the committee receives some concessions and benefits in lieu of their services in protecting the identified forest area. To this end, too much emphasis on community participation is really not necessary. The questions of how these benefits will be shared amongst the villagers and how the interests of the poor and women will be addressed should be left primarily to the village committee itself. The forest department does not have sufficient number of field staff to address the challenges of community organization, conflict resolution, profit sharing etc. It is , therefore, important that the village common lands must not be included under JFM.

### *Demonstration approach applied to large-scale production projects*

JFM is envisaged to be applied on a large scale to most parts of the country. However, the approaches applied successfully in a pilot or demonstration project in

one part of the country cannot be applied *in toto* in the entire country. Also the forest department can not possibly have a sufficient number of field staff to address the challenges of community mobilization. The objective of JFM is development and protection of the identified forest area. To what extent activities like the *entry programme, socio-economic survey, micro-planning, PRA* etc. conducted routinely help in achieving this objective need to be evaluated. The lack of a sufficient number effective field-level extension staff with requisite skills on working in partnership with the communities, is being addressed by imparting large-scale training at all levels.

### *Sense of Uncertainty*

Despite the existing guidelines, there is a sense of growing uncertainty amongst village forest protection committee members about sharing of the forest produce. Situations where the initial level of expectations of the village committee was relatively high and the subsequent benefits are found to fall far short of the expectations, can lead to wearing of the enthusiasm very quickly. The committee members in course of time may consider the projects as unfair, jeopardizing the future of Joint forest Management.

### *Carrying capacity of local forest*

Where local forest resources cannot continue to sustain local needs due to increasing population, people need to change the way they are using these resources. Alternative resource use practices must be introduced together with development of renewable energy sources to reduce the pressure on fuel wood, rather than just pursuing JFM more vigorously.

### *Integration with Watershed Management*

Many of the strategies for development of village level institutions adopted in joint forest management are strikingly similar to those recommended for watershed management. This is because, the approach and strategy for management of forests, are not only similar but are also an integral part of watershed management.

## **9.0 *Climate Variability***

---

### **9.1 CLIMATE AND WEATHER**

Climate refers to the sum total of weather conditions and variations over large area for a long period of time (more than 30 years). India has a tropical climate. Weather is the atmospheric condition over an area at any point of time (short duration). Weather conditions which last for longer duration are responsible for making the seasons. According to Vedic literature India has six seasons but IMD has identified four distinct seasons namely Winter, Summer (pre-monsoon), Monsoon (rainy season) and Autumn (post-monsoon). Both weather and climate are defined by certain variables known as climatic factors which are a) Solar radiation b) Ambient temperature c) Air humidity d) Precipitation e) Wind speed and f) Sky condition.

The factors that govern the climate of a particular region are:

#### **9.1.1 Location (latitude)**

India lies in the northern hemisphere broadly between latitude 8° to 36° North and longitude 68° to 96° East. The Equator (0°) latitude lies further south of India. The places which are closer to equator have high temperature. As moved towards the poles, temperature decreases. The 23.5° North latitude is known as Tropic of Cancer which runs along the States of Gujarat, Madhya Pradesh, Jharkhand and West Bengal. This imaginary line divides India in to halves, the southern half of India lies in the Torrid Zone and the northern half is in the Temperature Zone. For example, Andhra Pradesh would be hotter than Haryana. Broadly speaking parts lying south of the Tropic of Cancer receive more solar radiation (heat) than those lying north of it. On the other hand the 23.5° South latitude is known as Tropic of Capricorn.

#### **9.1.2 Distance from the sea**



The southern half of India is surrounded by sea from three sides. The Arabian Sea is in the west, Bay of Bengal in the east and the Indian Ocean lies in the south. The moderating influence of the sea in the vicinity of these region make them neither too hot in summer nor very cold in winter. Therefore, the areas of North India which is far away from the sea have extreme climates and the areas of south India which is nearer to the sea have equable type of climate.

### **9.1.3 Altitude**

Altitude refers to the height above the mean (average) sea level. As, the atmosphere (air) becomes thinner (less dense) with altitude, the air absorbs less and less heat of the Sun's rays. Thus, the temperature decreases with altitude and we feel breathlessness as we go higher from the earth surface. It is therefore natural that the cities located on the hills are cooler as in Darjeeling whereas the cities lying in the plains will have hot climate as in Siliguri.

### **9.1.4 Mountain Ranges**

Mountain ranges also affect the climate of any region to a great extent. The Himalayan Mountain is located in the northern part of India with an average height of 6000m above mean sea level. This mountain range play some important role in controlling our climate. In one hand, it protects our country from cold winds of Central Asia and on the other hand, it checks rain bearing South-West Monsoon winds causing extensive rainfall in the northern plain of India. A part of these rain bearing clouds later reflects back (Return Monsoon) as far as South India and causes considerable rainfall at places like Tamilnadu and Kerala Western Ghats force rain bearing winds to cause heavy rain fall on its Western slopes conversely creating a "Rain Shadow zone" in the immediate vicinity on its eastern side.

### **9.1.5 Direction of surface winds**

The wind system also affects the Indian climate. This system consists of monsoon winds, land and sea breeze, and local winds. In winter the winds blow from land to sea so they are cold and dry. On the other hand, in summer wind blow from sea to land bringing the moisture along with them from the sea causing wide spread rain in most part of the country.

### **9.1.6 Upper air Currents**

Besides surface winds, there also exist strong air currents in the upper atmosphere called Jet Streams which also influences the climate of India. These Jet Streams are a narrow belt of fast blowing winds located generally at 12,000 m above msl. They bring western cyclonic disturbances along with them. These cyclonic winds originate near the Mediterranean Sea and move eastwards. On their way, they collect moisture from Persian Gulf and shed it in the north western part of India during winter seasons. These Jet streams shift northwards during summer season and blow in Central Asia. This helps in the onset of monsoon.

## **9.2 KNOW YOUR EARTH**

Looking from space earth would look like a spheroid with patches of clouds (atmosphere) below which lies water of the oceans covering 71% area and the remaining are land surface. The oceans contain 97% of Earth's water and 99% of the living species on the planet. Earth has a solid Crust with average thickness of 40 km, a semi-solid Mantle of 2900 km and a liquid and very hot Core of 3510 km thickness.

Earth is a 4.5 billion years old spheroid with average diameter of 12756 km rotating anti-clock wise (from west to east) along an elliptical orbit of 149,600,000 km around the Sun. Earth rotates faster at the Equator than it does at the poles. Earth is wider at the Equator, so to make a rotation in one 24-hour period, equatorial regions race nearly 1,674 kilometers per hour. Near the poles, the Earth rotates at a sluggish 0.00008 kph. The rotation of earth is exactly similar to that of a playing Top - one around the sun, another on its own axis and the third is a minor and periodical swing on its axis.

The average tilt of earth's axis is  $23.5^\circ$  with earth's orbit. The seasonal changes in climate are due to the tilt of earth's axis. Every six months alternate hemisphere have more exposure towards sun. Extreme points in the elliptical path are solstices and the two mid points are equinoxes. At December solstice (December 21), the Northern hemisphere reaches its greatest tilt away from sun, hence sun is low in sky and daylight hours are short and temperature low. In contrast, the Southern

hemisphere receives maximum sunlight and sun is directly overhead at the Tropic of Capricorn. At June solstice (June 21), the conditions are reversed that is the sun is overhead the Northern hemisphere at Tropic of Cancer and daylight hours are longer in Northern hemisphere. The Arctic and Antarctic circles lie beyond  $66.5^{\circ}$  N and S latitudes of equator respectively. During this time there is perpetual day light at the North pole and perpetual night at the South pole. At the Northern winter solstice, the conditions are reserved. While the North pole experiences perpetual night, in the South pole “midnight Sun” is visible. March 21 and September 22 are the equinox when the day and night hours are equal.

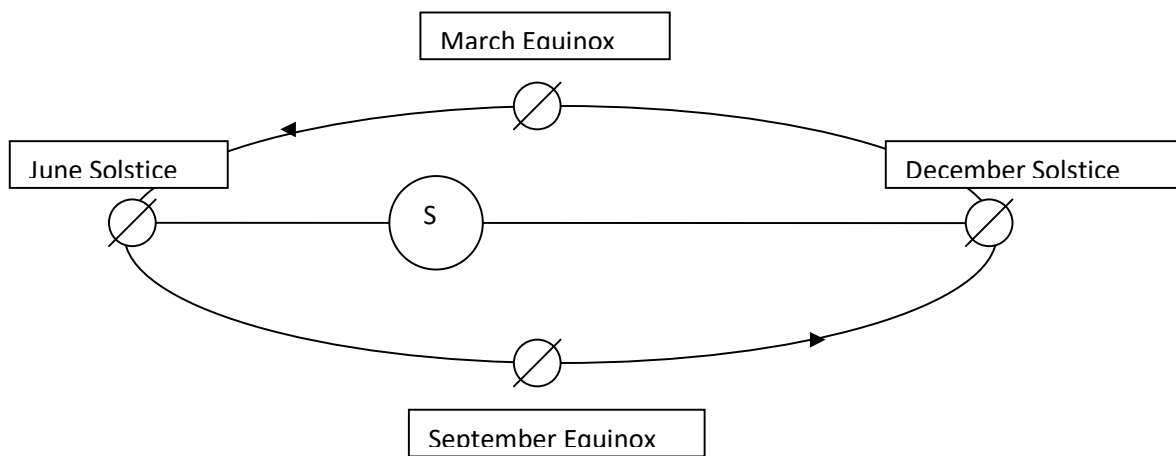

the Geological past, earth's temperature is believed to have changed due a change in its tilt angle.

The Tropic of Cancer is the circle marking the latitude  $23.5^{\circ}$  north, where the sun is directly overhead at noon on June 21, the beginning of summer in the northern hemisphere. The Tropic of Capricorn is the circle marking the latitude  $23.5^{\circ}$  south where the sun is directly overhead at noon on December 21, the beginning of winter in the northern hemisphere.

### 9.3 ATMOSPHERE

It is believed that 3.0 billion years ago, earth was filled with  $N_2$ ,  $NH_3$ ,  $SO_2$ ,  $CO_2$  and water vapors released due to its cooling. After temperature came down below

100° C, water vapor condensed and formed sea, lakes etc. Primitive life mainly algae produced their food by photosynthesis - a form of metabolism that converts CO<sub>2</sub> and water in to food (sugar) and released O<sub>2</sub> and O<sub>3</sub>. Ozone (O<sub>3</sub>) which are present in the upper atmosphere while absorbing Ultra Violet (UV) rays coming from the Sun also produce O<sub>2</sub>. Until 420 million years ago when the incidence of UV ray was reduced sufficiently due to increased Ozone layer, permitted plants to grow on lands. Since 30 million years O<sub>2</sub> started building up quickly emerging the way for O<sub>2</sub> breathing animals.

The emissions that comes from the Sun to the Earth are

- Radio wave (Feeble emitter)
- Ultraviolet (filtered out by atmosphere)
- X – ray (Short wave length, filtered out)
- Infrared (Responsible for heat balance)
- Visible light

The atmosphere protects the creatures living in Earth from most of the harmful radiations emanating from the Sun. Atmosphere is known to be composed of the following gases.

- Nitrogen (78.9%)
- Oxygen (20.95%)
- Argon (0.94%)
- Other gases (0.02%)
- Water Vapor (4% by volume)
- Carbon di Oxide (varies)

Earth's atmosphere is constantly circulating as heated from below due to the heat reflected back from the Earth's surface and from above to smaller extent by Sun's radiation. As Earth rotates along its axis from left to right (clock wise), rotation of Earth influences the rotation of the atmosphere (Coriolis effect). The result is deflection of atmosphere to the right in the northern hemisphere and to the left in the southern hemisphere.

### 9.3.1 Major Atmospheric layers

- The top most layer is Exosphere which occurs beyond 483 km.
- Ionosphere comprising of Mesosphere and Thermosphere occurs between 48–306 km. Temp first drops in Mesosphere and then increases steadily in Thermosphere.
- Stratosphere begins at about 48 km below which lies the troposphere. The lower part of the zone is the Ozonosphere containing Ozone (O<sub>3</sub>) layer. Ozone of the atmosphere reaches its highest concentration at 24 km above surface where it acts as shield to protect Earth from dangerous UV radiation incident from Sun.
- Troposphere (contains 75% mass of atmosphere), extends up to 10 km over poles and 16 km over equator. Troposphere is the height up to which clouds can occur.

## 9.4 MONSOON

In nature, wind blows from high pressure to low pressure zones. During summer months the temperature of the Indian land mass becomes relatively higher than that of the ocean in the south. As the temperature continues to increase from March to May, the atmospheric pressure in the Indian subcontinent decreases. When pressure decreases, air from the surrounding regions try to fill it up. The winds that bring rain to India come from the Australian side. After crossing the equator to the northern hemisphere the air moves up and turn towards north east due to the coriolis effect created by the rotation of Earth. As these winds are travelling all along the Indian ocean carrying large amounts of moisture, large scale precipitation takes place in India lasting from June to September. The southern most tip of Indian landmass breaks this wind into two parts- the Bay of Bengal branch and the Arabian Sea branch. Most of the winds blow towards the Bay of Bengal branch and reach the Himalayas.

Thus, moderate to heavy rainfall is received all over India thanks to the Himalayas that block the clouds from moving further north. This low pressure continues until mid October when the winds from Southwest stop getting attracted which means the high temperature region has cooled down due to the rains and become low to moderate temperature region. Now the pressure in the Indian landmass is more

than that of in the Indian ocean. Thus due to comparatively higher ocean temperature, low pressure is created and thus the winds that previously blew over India are now attracted back to their origin. These winds as they travel over the Bay of Bengal little moisture is picked up and this brings rainfall to mainly Tamil Nadu, Andhra Pradesh and Kerala. Thus high pressure continues until next summer when temperature increases and the whole cycle repeats itself. Jet streams, Tibetan Plateau, El Nino, Indian Ocean Dipole, Monsoon Trough, Cyclonic Storms and Mid Troposphere Cyclones are factors that also exert some influence in the movements of monsoon air flow towards India.

## **9.5 TEMPERATURE**

Temperature is the measure of presence or absence of heat. The maximum and minimum temperature of different locations in India varies widely as per season during a year. For example, Jammu & Kashmir which is in the northern border of the country has recorded extreme temperature of maximum  $39.7^{\circ}\text{C}$  at Katra in 1987 and minimum of  $-18.6^{\circ}\text{C}$  at Pahelgaon in 1986. Rajasthan located at the western boundary of the country experienced the extremes of maximum of  $49.7^{\circ}\text{C}$  at Tonk in 1969 and minimum of  $-5.9^{\circ}\text{C}$  at Jaisalmer in 1967.

The maximum and minimum temperatures are recorded on daily basis which are then averaged for monthly and yearly values. Mean (average) annual temperature in the country varies from  $8^{\circ}$  to  $28^{\circ}\text{C}$ . Variations in the mean summer and mean winter temperature in the northern region is greater than  $10^{\circ}\text{C}$  and in the south, it is less than  $5^{\circ}\text{C}$ . During summer, temperature rises to  $25^{\circ}$ – $30^{\circ}\text{C}$  in the central peninsula, more than  $32^{\circ}\text{C}$  in the north-west region and less than  $25^{\circ}\text{C}$  in the north-east region. In monsoon season (June, July, August), temperature varies between  $25^{\circ}$  and  $30^{\circ}\text{C}$  throughout the country, except Rajasthan, where it is higher than  $32^{\circ}\text{C}$ . After withdrawal of the monsoons, with the advent of winter (October), temperature ranges from  $25^{\circ}$  to  $27^{\circ}\text{C}$  in most of the places. Maximum temperature observed during May–June is in the west Rajasthan, where it is as high as  $55^{\circ}\text{C}$ . In April, along the west coast, highest temperature recorded is  $37^{\circ}\text{C}$ .

In eastern Madhya Pradesh, Chhotanagpur plateau, eastern part of Vidarbha and in adjoining Andhra Pradesh, temperature may rise (highest temperature) to  $47.5^{\circ}\text{C}$  during May. In other parts of the country, summer temperature generally varies

from 37° to 45°C. During December–January, lowest temperature of –2.5°C is recorded in Drass valley in Jammu and Kashmir. In western and north-western parts of India, average minimum temperature is generally less than 7.5°C during January. North Deccan plateau and some parts of central India experience temperature between 10° and 17.5°C. Southwards temperature reaches up to 22.5°C in south Deccan plateau and adjoining areas. In eastern parts (Bengal basin), mean minimum temperature ranges between 10° and 12.5°C. Similarly, in the north-eastern parts, mean minimum winter temperature remains between 10° and 12.5°C, excepting parts of Nagaland and upper Assam valley, where minimum temperature is less than 10°C.

## **9.6 CLIMATE CHANGE**

Over the Geological past, the temperature of the Earth is believed to have changed due various natural reasons. But while talking about climate change in the present day context, we usually refer to the expected changes in climate due to human (anthropological) activities like large scale burning of fossil fuels, industrial productions, deforestation and the like.

Solar energy that reaches Earth is absorbed by its surface. Much of this heat is reflected back from Earth's surface to the atmosphere helping in maintaining the near surface temperature of Earth. But as air pollution is on the rise and amount of various gases are increasing in the atmosphere, some of the reflected heat is unable to go back to the atmosphere. As some of these gases are heavier than the air, they produce a cover (canopy) like a “Green House” over the surface of the Earth and hence known as Green House Gases (GHGs). Carbon dioxide (CO<sub>2</sub>) is the most common GHG which being heavier than air settles closer to the surface and forms the heat trap. This trapping of heat by the GHGs are likely to increase the temperature of the Earth's surface. Other known GHGs are Methane (CH<sub>4</sub>), Nitrous Oxide (N<sub>2</sub>O), Hydrofluorocarbon (HFC), Perfluorocarbon (PFC), Sulphur Hexafluoride (SF<sub>6</sub>) etc.

Concentration of CO<sub>2</sub> is known to have increased from 285 ppm before Industrial revolution to 315 ppm by 1958 and to 338 by 1980 due to burning of fossil fuel and deforestation. It has been estimated that a concentration of 570 ppm could raise global temperature by 3°C. There is evidence to show that CO<sub>2</sub> levels are still

increasing all over the world. The impending increase in Global temperature referred as Global Warming is likely to disturb the existing climate pattern and almost all aspects of the living beings in the planet.

During the past decades of urbanization, industrialization and population growth, the atmosphere has been polluted. Human activities are producing different GHGs at different rates in different countries. A Global increase in temperature will have an adverse effect all over the world including India with such a large population. Climate Change as defined by the Inter-Governmental Panel of Climate Change (IPCC) refers to a change in the state of the climate that can be identified by changes in the mean and /or the variability of its properties that persists for an extended period, typically decades or longer. It refers to any change in climate over time, whether due to natural variability or as a result of human activity. Many countries have signed conventions to reduce GHGs under the United Nations (UN) framework. However, the current international initiatives are yet to be effective enough to prevent any significant change in the climate.

## **9.7 POTENTIAL IMPACTS**

It is obvious that an increase in average temperature of Earth's atmosphere even by a few degrees can bring about unpredictable changes in Global climate. There will be serious socio-economical ramifications. Our food, festivals, economy, health, everything is closely linked with the cycle of seasons. If the seasons are favorable, human life will be good and comfortable. The effects of climate change on human life is seen by different groups through different prisms as per their primary concerns. In this document, we will focus our attention only on the effect of climate change on Natural Resources.

Changes in temperature can cause corresponding changes in rainfall pattern affecting our fresh water sources and agriculture. Emergence of some specific pest species and diseases may also affect our agriculture and health. Extreme Weather Events such as the recent incidents of high intensity cyclones and Typhoons in some parts of the world are perhaps a harbinger of future behavior of nature to come. There has been an overall increasing trend in severe storm incidence along the coast at the rate of 0.011 events per year. While the states of West Bengal and Gujarat have reported increasing trends, a decline has been observed in Orissa



(Goswami et al). Analyses of daily rainfall data set have shown a rising trend in the frequency of heavy rain events and a significant decrease in the frequency of moderate events over central India from 1951 to 2000. The incidence of lightning related deaths has also been reported to have increased in Orissa.

### **9.7.1 Impact on Rainfall**

An unpredictable climate could affect the rainfall pattern wherein it may cause excessive rainfall at one region leaving others dry. While the observed monsoon rainfall at the all-India level does not show any significant trend, regional monsoon variations have been recorded (IPCC, Report no ). A trend of 10-12% increase in long term (100 years) normal monsoon rainfall has been observed along the west coast, northern Andhra Pradesh, and north-western India while a trend of 6-8% decrease in long term (100 years) monsoon rainfall has been recorded over eastern Madhya Pradesh, north-eastern India, and some parts of Gujarat and Kerala. An unpredictable rainfall pattern with varying intensity could result in unexpected floods and drought of not only with more frequency but perhaps also with greater intensity. Changes in rainfall and temperature will correspondingly affect the soil moisture, groundwater recharge and crop production.

### **9.7.2 Impact on Glacier Melt**

There has been a 40% decline in Arctic Sea ice thickness in late summer to early autumn in the past 45–50 years. The global mean sea level has reported to have risen by 10 to 20 cm. The frequency of severe floods in large river basins has increased during the 20th century. Also, synthesis of river-monitoring data reveals that the average annual discharge of freshwater from six of the largest Eurasian rivers to the Arctic Ocean has increased by 7% from 1936 to 1999. In India, studies by several authors show that there is indeed an increasing trend in surface temperature. However barring some decreasing/increasing trends in rainfall at some locations, there have been no major change in rainfall on all India basis.

The Himalayas glaciers form a source of water for the perennial rivers such as the Indus, the Ganga, and the Brahmaputra. Glacial melt may impact their long-term lean-season flows, with adverse impacts on the economy in terms of water availability and hydropower generation. The available monitoring data on

Himalayan glaciers indicates that while recession of some glaciers has occurred in some Himalayan regions in recent years, the trend is not consistent across the entire mountain chain. It is too early to establish long-term trends, or their causation, in respect of which there are several hypotheses.

### **9.7.3 Impact on Availability of Fresh water**

Changes in key climate variables, namely temperature, precipitation, and humidity, may have significant long-term implications for the quality and quantity of water. River systems of the Brahmaputra, the Ganga, and the Indus which benefit from melting snow in the lean season are likely to be particularly affected by the decreased snow cover. A decline in total run-off for all river basins except Narmada and Tapi have been predicted. A decline in run-off by more than two-thirds is also anticipated for the Sabarmati and Luni basins.

Presently, more than 45% of the rainfall in the country is wasted by natural runoff to the sea. Rainwater-harvesting schemes being implemented in the country are not adequate to sufficiently store this run-off to meet local needs and increase groundwater recharge. However, for the success of these water harvesting schemes we should have enough knowledge about how the possible climate change may affect the rainfall intensity, run-off, infiltration, evaporation and groundwater recharge in different agro-climatic regions and river basins of India.

A number of studies have been conducted to assess the impact of climate-change scenarios on hydrology of various basins and regions. In a number of studies, it is projected that increasing temperature and decline in rainfall may reduce net recharge and affect groundwater levels. However, little work has been done on hydrological impacts of possible climate change for Indian regions/basins.

### **9.7.4 Impact on Agriculture**

Crops and biodiversity are highly sensitive to temperature. Changing temperature regime could bring about a marked change in seasons changing cropping pattern and a geographical shift in growing area for a particular crop. Increased depletion of soil organic matter, soil erosion, changes in pest profile etc. would be serious threats to agriculture.

Simulation studies conducted by ICAR, projected reduction in yields of irrigated kharif maize by nearly 18% in 2050 and about 23% in 2080 due to climate change. Rainfed sorghum yield, on all India scale, are projected to marginally (2.5%) decline in 2020 scenario and about 8% in 2050. Similarly, the irrigated rice yields are projected to reduce by about 4% in 2020, 7% in 2050 and by about 10% in 2080 scenarios. On the other hand, rainfed rice yields in India are likely to be reduced by about 6% in 2050 and decrease only marginally (< 2.5%) by 2080. Irrigated rice in north-west India, comprising of Haryana and Punjab is projected to lose more (6-8%) than in other parts of the country (< 5%) in 2020 scenario. Yield loss will be more in 2050 scenario in north-west India (15-17%) while some parts of central India (Maharashtra and Madhya Pradesh) also are projected to face less than 5% of yield loss.

Climate change is projected to reduce the timely sown irrigated wheat production by about 6% in 2020 scenario from the existing average value. In case of late sown wheat, the projected reductions are to the extent of 18%, 23% and 25% in 2020, 2050 and 2080 respectively. The above figures however are only indicative in nature. Adaptation measures like use of stress tolerant varieties, judicious use of water and soil moisture, fertilizers and pesticides, improved agriculture practices, organic farming and agro-forestry interventions can offset the negative impacts of climate change.

### **9.7.5 Impacts on coastal areas**

The vulnerability of coastal districts based on physical exposure to sea level rise has been assessed by (NATCOM, 2004). The fresh water sources near the coastal regions will suffer saline water intrusion due to a rise in the sea level. Using the records of coastal tide gauges in the north Indian Ocean for more than 40 years, Unnikrishnan and Shankar have estimated that sea level rise was between 1.06-1.75 mm per year. These rates are consistent with 1-2 mm per year global sea level rise estimated by IPCC. A mean Sea Level Rise (SLR) of 15-38 cm is projected along India's coast by the mid 21st century and of 46-59 cm by 2100. In addition, a projected increase in the intensity of tropical cyclones poses a threat to the heavily populated coastal zones in the country.

It should however be remembered that sea level variation is highly dynamic in nature. The static sea level of the earth follows an equi-gravitational surface called Geod. Thus excess water in one part of the ocean, if any gets distributed along this equi-gravitational surface. Sea level rise therefore is not a local but a global phenomenon. We are familiar with the daily and monthly variations in sea level as manifested by high and low tides. Sea level also rises temporarily when the air above its surface moves at a high speed creating a low pressure region during cyclones. The high tides thus created inundates the coastal areas.

### **9.7.6 Impacts on Forests**

Plants are known to absorb CO<sub>2</sub> and release O<sub>2</sub> through the process of Transpiration. In addition to the numerous services Forests are known to provide, another important service rendered by Forests are to perform the task of absorbing Carbon di Oxide. For this reason, forests are also referred to as Carbon Sink. Climate change can see the emergence of new pests which may inhibit the normal growth of forests. Increased global temperature can also render a forest dry and bare of leaves during the summer months making them vulnerable to large scale forest fire.

Every country, as per International norm should ideally have 33% of its geographical area under forest cover. India has nearly 22% of its geographical as Forest land which has remained more or less the same over past 3 decades. In addition, India has also promoted large scale decentralized forestry activities known as Social forestry. Large scale plantation have been undertaken along the roads, railways lines and in other common lands. Farmers are increasing planting commercially useful trees in their farm lands known as Agro forestry. In fact, barring a few commercial species, cutting of trees are legally prohibited in India. Estimates indicate that presently forest land in India sequesters 60-70 million tons of CO<sub>2</sub> per year.

## **9.8 CLIMATE CHANGE ADAPTATION AND MITIGATION**

Climate adaptation refers to the ability of the people in general to adjust to the adverse effects brought about by climate change including climate variability and extremes so as moderate its potential damage and cope with the consequences. The

IPCC defines adaptation as the, adjustment in natural or human systems to a new or changing environment. In other words, it is the adjustment in natural or human systems in response to actual or expected climatic stimuli or their effects which moderates harm or exploits beneficial opportunities. It involves taking practical actions to eliminate possible negative impacts from climate change, protect communities and strengthen the resilience of the economy. Various types of adaptation can be distinguished, including anticipatory and reactive adaptation, private and public adaptation, and autonomous and planned adaptation etc.

Mitigation addresses elimination or reduction of the causes of climate change which primarily is the accumulation of greenhouse gases in the atmosphere. Climate mitigation is any action taken to permanently eliminate or reduce the long-term risk and hazards of climate change to human life and property. It is an anthropogenic intervention to reduce the sources or enhance the sinks of greenhouse gases. Forests act as a large absorbent (sink) for CO<sub>2</sub>. Climate change mitigation involves working towards a complex balance amongst environmental, economic, political, institutional, social, and technological processes.

Examples include designing cars and cities to use less energy as well as alternative forms of energy that do not require burning fossil fuels that produce carbon emissions. Climate change adaptation and mitigation differ in that climate change adaptation adjusts society and ecosystems to endure climate change while mitigation adjusts society and ecosystems to prevent climate change. It cannot be addressed or comprehended in isolation.

## **9.9 INTERNATIONAL ACTIONS**

The United Nations Convention on Environment and Development (UNCED) initiated its first Earth Summit at Stockholm (1972) to discuss on World Environment and achievements on Millennium Development Goals (MDG). This was followed by Earth Summits at Nairobi (1982) and at Rio de Janeiro (1992) to shift the focus gradually on Climate Change. Initially there had been no mandatory controls or deadlines on reduction of Carbon Foot Prints. The 1997 Kyoto Protocol did set mandatory limits. Many countries gave themselves targets to reduce burning of fossil fuels, use of non-conventional and less polluting renewable

energy, increasing energy efficiency, reducing air pollution, growing and maintaining forests as carbon sink and the like.

In the Paris agreement in 2015 organized under the aegis of UNFCCC, India played a key role and committed to reduce carbon emission in the country to a considerable extent. India also launched a “Solar Alliance” involving 87 countries. Attention was also focused on issues like water management, protection of biodiversity, watershed management etc.

The Inter-Governmental Panel on Climate Change (IPCC) is an umbrella organization that highlights the concerns of the climate scientists. It was created to provide policy makers with regular scientific assessments On climate change, its implications , potential future risks and to suggest adaptation and mitigation options. It assembles and synthesize the works of many scientists from all over the world. Currently, it has about 200 institutional members.

## **9.10 NATIONAL ACTION PLAN**

The National Action Plan on Climate Change identifies measures that promote our development objectives while also producing benefits to address development and climate change-related objectives of adaptation and mitigation. The GoI on 2005 adopted eight National Missions on Climate Change. These are:

- **National Solar Mission:** Aims to promote the use of solar energy in India by making it competitive with fossil fuels. It will promote activities to encourage research and development to improve efficiency and affordability of solar power and energy storage systems.
- **National Mission for Enhanced Energy Efficiency:** Aims to improve energy efficiency of domestic, commercial and industrial sectors in India by creating an enabling policy regime and encouraging innovative business models for improving energy efficiency.
- **National Mission for Sustainable Habitat:** Aims at encouraging sustainable urban planning in India with the help of policy, infrastructural and research interventions in sectors such as buildings, waste management, water

resources and transportation.

- National Water Mission: Aims to ensure sustainable water supply by conserving water, minimizing waste and ensuring equitable distribution of water resources throughout India.
- National Mission for Strategic Knowledge on Climate Change: Aims to create a comprehensive knowledge system that informs and supports climate change action in India with the help of research and communication-based actions.
- National Mission for Sustainable Agriculture: Aims at improving sustainability, productivity, remuneration and climate resilience of agriculture in India. These goals will be achieved by capacity building, research, infrastructural and institutional interventions in the Indian agricultural sector.
- National Mission for Green India: Aims to protect, enhance and restore forests and respond to climate change with appropriate adaptation and mitigation activities. It plans to increase green cover and focuses on multiple ecosystem services—especially biodiversity, water, biomass, mangroves, wetlands and critical habitats, with carbon sequestration as a co-benefit.
- National Mission for Sustaining the Himalayan Ecosystem: Aims to enhance understanding of climate change impacts and adaptations required in the Himalayas. The information obtained from this mission will feed into policy formulation for suitable management practices for the Himalayan ecosystem.

The National Water Mission for example, has been mounted to ensure integrated water resource management helping to conserve water, minimize wastage and ensure more equitable distribution both across and within states. The Mission will take into account the provisions of the National Water Policy and develop a framework to optimize water use by increasing water use efficiency by 20% through regulatory mechanisms with differential entitlements and pricing. It will seek to ensure that a considerable share of the water needs of urban areas are met

through recycling of waste water, and ensuring that the water requirements of coastal cities with inadequate alternative sources of water are met through adoption of new and appropriate technologies such as low temperature desalination technologies that allow for the use of ocean water. The implementation of the Plan would be through appropriate institutional mechanisms suited for effective delivery of the Mission's objectives and include public private partnerships and civil society action. The focus will be on promoting understanding of climate change, adaptation and mitigation, energy efficiency and natural resource conservation.

## **9.11 BROAD BASED APPROACH**

It therefore clear that a large number of activities are to be initiated at different levels by different people in order to meet the challenges of Climate Change Mitigate, Adaptation and Disaster Management. A brief list of these activities are presented below for ready references.

### **9.11.1.1 Adaptation and climate risk reduction**

- strengthen early warning systems
- increase capacity to prepare responses to climate risks
- increase capacity to manage water resources
- increase access and capacity to capture, store, treat and distribute water
- increase the resilience of agriculture and livestock
- increase the resilience of fisheries
- guarantee adequate levels of food security and nutrition
- increase the adaptive capacity of vulnerable people
- reduce people's vulnerability to CC-related vector-borne diseases
- promote mechanisms for planting of trees, and establish forests for local use
- develop resilience mechanisms for urban areas and other settlements
- suit the development of tourist zones and coastal zones to reduce the impacts of CC

### **9.11.1.2 Mitigation and low-carbon development**

- improve access to renewable energy



- increase energy efficiency
- guarantee the development of regulations dealing with emissions from the extractive industries
- promote low-carbon urbanization
- control emissions from industrial processes, including solid waste and wastewater
- develop low-carbon agricultural practices
- reduce deforestation and the occurrence of wildfires
- plan and manage biodiversity and coastal ecosystems
- manage and set a price for waste

### **9.11.1.3 Cross-sector issues**

- align the current legal framework with the NCCAMS
- align the current institutional framework with the NCCAMS
- develop research on CC
- strengthen institutions' systematic data collection on inputs to GHG inventories and National Communications
- develop the level of knowledge and capacity to act on CC
- promote the transfer and adoption of clean and CC-resilient technologies

To facilitate the implementation of this cross-sectoral Strategy including the participation of actors from the community of national level

## **9.12 DISASTER MANAGEMENT**

Disaster Management can be defined as the organization and management of resources and responsibilities for dealing with all humanitarian aspects of emergencies through preparedness, response and recovery in order to lessen the impact of disasters.

While we have no control on the occurrences of natural disasters, we can make preparations to limit their consequences on the affected people. The challenges of facing these natural disasters is to find a way to live with these phenomena rather than suffering inordinately from them. Natural disasters keep happening, the people who suffer are those who are in the wrong place at the wrong time. The

scale of disaster is also linked closely to the level of preparedness of the people and the authorities. Pre-emptive risk reduction is the key. Eventually, these preparedness leads us to initiate forward looking policies that contributes to overall sustainability.

India's Ministry of Home Affairs has overall responsibility for disaster management along with India's National Disaster Management Authority (NDMA). Components of the national disaster management structure include the National Executive Committee (NEC), which assist the NDMA with overseeing national disaster management activities. The Central Government which maintains the authority issues guidelines to NEC, State Governments and State Emergency Committees (SECs) to enable and aid in disaster management. All central ministries are involved in DM post disaster recovery activities. The State Governments are responsible for the primary function of coordinating disaster management activities to include proper establishment of early warning systems (EWS). The Armed Forces are a significant component of India's disaster management structure and are mandated to assist the civil administration only when the circumstances of the disaster are beyond the State's coping capacity and when requested by the Civil Administration. Additionally, the Central Paramilitary Forces (CPMFs), the State Police Forces and Fire Services, Civil Defense, Home Guards and the State Disaster Response Force (SDRF) play a role in disaster response.

Disaster management is a post disaster short duration activity while climate change adaptation are measures to cope with the effects of potential climate change. From NRM point of view, we are concerned primarily about disasters associated with crop failures (destruction) due to inclement climate like flood and drought. There is a need to improve the capacity of all the stake holders primarily farmers against potential climate change to enhance their resilience capacity.

But in case there is a disaster in term of crop loss due to flood, drought and pest attacks, the Pradhan Mantri Fasal BimaYojana (PMFBY), a crop insurance scheme introduced recently by Central Government aims to provide relief against such disasters.

### **9.13 CAPACITY BUILDING**

Farmers are the one who suffer directly due to the vagaries of climate such as untimely rainfall, excessive rain fall, cyclone, drought, pest attack etc, which makes them the primary stake holder. The Government institutions that make policies and undertake measures to ameliorate the adverse effects are the secondary stake holders.

Unlike many other countries, India does not have a dedicated platform like open schools for farmers to upgrade their skills and knowledge. We have at least one Krishi Vigyan Kendra (KVK) in each State with the specific purpose of providing local farmers with the technical know-how. The State of affairs in these KVKs are far from satisfactory. As the efforts of the Government departments falls short of the varied needs of our farmers, there is a strong case for promotion of more Service Delivery Organizations (SDOs) to build capacity of our farmers and sustain our Agriculture.

Capacity building for climate change adaptation must therefore be focussed at the farmers on priority basis. Capacity building of the farmer community may be envisaged as developing a mechanism through which the skill and knowledge base of the farmers are so enhances that they become capable of meeting the consequences of the adverse effects of Climate variability on their agriculture.

*Capacity Building* is by far the most useful Outcome of a Watershed Management project. The communities usually possess sufficient skills in the trade they are engaged in and earn their livelihood from. What the communities really lack is in their ability to organize themselves for a positive cause and manage adequately the fast changing socio-economic environment around them. Capacity building, in the context of watershed management would, therefore, mean that the communities become aware of the values of the natural resources at their disposal, identify the process through which these resources are being degraded and learn to adopt practices which give increased productivity per unit application of inputs, without further degrading the resource base. This requires evolution of a special management mechanism for the conservation, development and utilization of the individual as well as the common property resources which is what a watershed

committee is supposed to address. Formation of a well-organized community institution and use of appropriate technologies are the key requirements.

## ***10.0 Project Formulation***

---

### **10.1 TYPES OF PROJECT**

A project is a set of inter-related activities designed to achieve certain objectives within a given time, budget and environment. Certain resources are used in a project to gain the intended results. The former will be considered as the cost and its impacts as the benefits. Main objective of a commercial project is well-defined which is measured in terms of its profitability. The same is, however, not applicable to development projects. Hence it is all the more important to define the objectives of each development project as precisely as possible, highlighting the benefits to be accrued to the target groups.

Depending upon the underlying philosophy and the priorities, *development projects* can have several definitions. A development project in the simplest sense is viewed as planned utilization of resources to satisfy the stated needs. It is the process of transition from an unsatisfactory situation to a more satisfactory situation. Development projects are necessarily multi-dimensional in nature. The aims of these projects are not only to benefit the identified individuals or the groups but also to address other social, cultural and environmental needs of the region. Selection of priorities based on development philosophy remains the prerogative of the funding agency. However the onus of translating the same in to reality is eventually transferred to the implementing agency. Each project has an important function to serve. Accordingly, projects may be categorised as:

- Experimental projects
- Pilot projects
- Demonstration projects
- Production projects

#### **10.1.1 Experimental Projects**

These are undertaken to assess the effectiveness of alternative solutions to an already identified problem. Sometimes even the problem may be defined in a slightly different way. Some experimental projects may concentrate on applying solutions that have already been applied successfully elsewhere to see if it works in this case as well. Alternately, a new solution to a region specific problem may be applied to ascertain the efficacy of these new approaches. The emphases of these projects are more on the process than the product itself. Experiences gathered from such projects are documented systematically in refining the design of future projects, i.e the second-generation projects.

### **10.1.2 Pilot Projects**

These are the testing grounds for the applicability of new approaches and technologies for the solution of a specific problem. These may be designed on the basis of experiences gained from experimental projects or even designed ingenuously. A pilot project attempts to test on a reduced scale what could later be applied on a larger scale under similar conditions. The size of the project and amount of funds utilized are kept to a modest level. Failures are accepted and as such do not cause any undue repercussions.

### **10.1.3 Demonstration Projects**

These are somewhat similar to pilot projects but are taken up on a larger scale with wider objectives. A substantial amount of success is expected to demonstrate the efficacy of the new approach or technology applied in such projects. These projects highlight the constraints and demonstrate the extent to which success could be achieved. The results of demonstration projects play an important role in influencing future policy guidelines.

### **10.1.4 Production Projects**

Projects which have gone through one or all of the above stages finally reach a stage of large-scale replication. Production projects may also be taken up without going through all the earlier stages because many projects do not require substantial innovations except in the areas of managerial efficiency and operational flexibility under varied conditions. In India, the Centrally sponsored projects

promoted along with a set of guidelines for large scale implementation by all the State Governments, are the typical example of production projects.

## **10.2 ANALYSIS OF PROJECT ELEMENTS**

Procedures for initiating projects to be implemented by State Government departments under funding from the Central Government are administratively well defined and are beyond the scope of detailed discussion here. The present discussion on project formulation applies to projects to be implemented by the voluntary agencies. Some aspects of project formulation, however, remain more or less the same, irrespective of who the implementing or the funding agencies are and hence some overlaps are likely to occur.

Project formulation generally gets influenced by the strengths and weaknesses (biases) of the project formulating agency. Many a times, projects are designed keeping in mind the priorities of the funding agency. Certain basic principles of project formulation, however, remain the same, irrespective of the nature of the funding and the implementing agency. Prior to the formulation of a project proposal, it is necessary that structured discussions such as focused group discussion or Participatory Rural Appraisal (PRA) are held with the potential beneficiary communities to identify the core problems and their possible solutions. In order to formulate a realistic project proposal, adequate attention should be made in analysing the following.

### **10.2.1 Target Group Analysis**

Understanding the target groups, their needs, capabilities, limitations, expectations, attitude etc. is the essential prerequisite for a successful project design. In the project document the target groups should be clearly defined with their relevant socio-economic profiles and geographic distributions. The quantitative and qualitative benefits expected to accrue, the number of people to get such benefits, the time frame within which this is likely to happen should be laid down in the project proposal as specifically as possible.

If the results to be accrued are likely to benefit the communities in varying degrees, then an analysis should be made to highlight the groups who tend to gain more and those who tend to lose in the bargain. Provisions for suitable compensatory measures for those groups who are likely to lose due to the project implementation should be an integral part of project formulation. Conservation projects, the long-term benefits of which are not easily conceived by many tend to concentrate only on short-term direct benefits. The task of project formulation team also includes sharing with the user groups the virtue of restraints or seeking alternatives to facilitate long term approach to resource conservation. It would be a larger challenge to quantify the direct and indirect benefits to be accrued from such a large conservation project e.g Wetland management projects.

### **10.2.2 Problem Analysis**

One of the earlier steps of project formulation is problem analysis. Problems are negatively stated situations. It is recommended that the problems be viewed not as an absence of solutions but an existing negative state. For example,

- “No handpump in the village” is wrong framing of a problem. The correct framing would be “No safe drinking water available in the village”.
- “No water harvesting structures exist in the watershed is wrong framing of problem. The right framing would be “There is lack of water for growing crops in the village”.
- “No soil and water conservation measures exist in the watershed is wrong framing. The right framing would be “Large scale soil erosion is taking place in the watershed”.
- “Schools are very far away” is a wrong framing. The correct framing of a Problem statement would be “There is no school in the village.”

Framing of a problem as an existing negative state is useful in searching a number of alternative solutions for a single problem. Major problems are identified on the basis of available information. A single major problem may then be broken down into a number of smaller problems. An arrangement of problem statements in a order of hierarchy, relating them as cause and effect with a lower level problem to its next higher level problem respectively, is known as a *problem tree*.



Replacement of problems with corresponding solutions generates the *outputs* which in turn lead to the fulfilment of the *objective* of the project.

### **10.2.3 Objective Analysis**

The objective of a project should be the future solution to the focal problem. An *objective tree* is obtained just by replacing each problem in the problem tree with a corresponding positive desirable statement by working from down to upwards. It should be ensured once again that the means-end relationships remains valid while doing the alternative analysis. If necessary, statements must to be revised, deleted or even a new objective statement may be added. Objectives which are obviously not desirable should be deleted and those not achievable during the project period should not be included.

### **10.2.4 Alternative Analysis**

The objective of alternative analysis is to identify the possible alternatives available towards the solution of the focal problem. Alternative analysis usually gets influenced by the past experiences of the project planners, their concerns, priorities, development perspectives etc. The choice of technology, mode of implementation, budget, convergence of benefits, strategy for operation and maintenance etc. also change accordingly. Alternative analysis is a task which must be performed with great care as this has to deal with situations comprising conflicting interests. The aspects of Sustainability and equity are to be kept in mind. A few simple examples of project alternatives are listed below.

- The project will adopt a community-driven bottom-up approach rather than a top-down. Improved traditional designs need to be adopted for construction of all physical structures using locally available reliable materials instead of applying standard department-based designs.
- Availability of groundwater should be tackled by artificial recharge instead of deepening the existing wells.
- A number of smaller water-harvesting structures will be preferred rather than a few large ones.
- Subsidy for sprinkler irrigation will be given to those farmers willing to discontinue growing heavy water consuming crops.

- Use of bio-fertilizer will be promoted against the use of inorganic fertilizers.
- Priority for benefits to a farmer will be decided on the basis of his land holding rather than his caste affiliation.

### **10.2.5 Project Inputs**

One of the dilemmas faced during project formulation is not only the decision concerning which of the problems of the area are to be addressed but also the decision as to what extent these problems will be tackled. As more and more inputs are applied in a project area, more and more development is likely to take place. Theoretically, following the law of diminishing returns, initially, as the inputs are applied, the returns (growth) take place at a faster rate. At one point in the growth curve, the increment in return (results) per unit application of inputs nearly stabilizes but the total return still continues to grow, albeit at a slower rate. Beyond a critical level, marginal increment in return starts declining. For optimum development, application of watershed management inputs should, therefore, be restricted to somewhere in the middle of the growth curve, i.e. in the plateau region. However, the limitations imposed by this classical theory of diminishing returns perhaps can be overcome by making the project more broad-based, i.e. by providing sub-optimal inputs to a larger number of problems rather than trying to solve one single problem (maximise one output) from application of a large number of inputs (Activity).

### **10.2.6 Skeletal Plan**

A project may be formulated on the basis of a skeletal plan (Concept Paper) as may be obtained from a PRA or after conducting an elaborate survey and investigations. A simple project proposal without necessary details is not likely to satisfy a funding agency. Conversely, formulation of an elaborate project proposal down to its minute details without an assured source of funding is also untenable. Moreover, preparation of a very elaborate plan well in advance does not necessarily guarantee successful implementation of the project at a later stage. This dilemma needs to be sorted out through discussions with the intending funding agency.

Most funding agencies have their own guidelines or Formats for appraisal of a

project proposal. Though, the basic contents of these Formats are more or less the same, they are structured differently, depending upon the size of funding and the needs, experience and priorities of the funding agency. In order to do a *perfect job*, specially while dealing with larger funding, these formats, sometimes seek answers to many aspects of resource endowments and project implementation, much before the initiation of project formulation. For the sake of initial screening, a format should be made such that the answers to many of the queries can be provided meaningfully without going through the process of conducting an elaborated survey. A format which asks questions that cannot be answered without carrying out a detailed survey, must be used only after a preparatory or an inception phase has been allowed and funded.

It is, however, prudent to first submit a proposal in a descriptive form (*concept paper*). A revised proposal may be submitted later in the standard format which will eventually be supplied by the funding agency, if the proposal appears to them worth considering. While considering a project proposal, many funding agencies place emphasis on the project approach, based on which the project is formulated as well as implemented later. While some funding agencies may insist upon the adoption of a process approach, allowing the project to develop as it goes, others may prefer a well laid down work plan and monitoring plan in place following a *Result Based Management* approach. Whatever may be the implementation strategy, necessary definition and clarification of the basic elements of the project, viz. the project Goal and Purpose, beneficiaries, problem identification, location of the project area, funding requirement etc., are required in all cases.

### **10.3 CONTENTS OF A PROJECT PROPOSAL**

A standard proposal for a watershed management project should include the basic information as outlined below, irrespective of which funding agency is being addressed.

#### **10.3.1 Title of the Project**

Choosing the title of a project is the privilege of the project proponent. Adoption of a project title normally follows a pattern. Ideally speaking, the title apart from being catchy, should be such that it gives a sufficient idea of what the project aims

to achieve, for whom and in what region. Some typical examples of some project titles are presented below:

- Community Based Integrated Watershed Management in 12 villages in the arid region of Rajasthan.
- Eco-development and natural resource management through community participation in 7 villages in the Western Ghats region.
- Agricultural development through integrated land and water management in 15 watersheds in the Bundelkhand region.

### **10.3.2 Description of the Project Area**

The project area should be described giving physiographical features of the region as a whole and the project area in particular including the natural resource endowments; their current use, level of degradation, causes of degradation etc. A possible approach for improving the situation should also be indicated after meaningful analysis. The entire techno-ecological set-up of the project area can be described under the following sub-headings.

- Location and extent
- Climate and rainfall
- Drainage and physiography
- Infrastructure
- Demography
- Agriculture
- Irrigation infrastructure
- Livestock
- Vegetation
- Environmental concerns
- Special feature, if any

### **10.3.3 Goal and Purpose of the Project**

The philosophy prompting the undertaking of a project is expressed in its *Goal* statement. The *Purpose* of a project is what the project desires to actually achieve.

The Goal is the long-term objective which is a desired state but is not promised even after the project is implemented successfully. Attainment of the Goal also requires fulfilment of other conditions or contributions from other projects. However, Purpose is the immediate objective that the project wishes to achieve and which it should be able to deliver on successful implementation of the project.

The Purpose statement should be framed in such a way that on successful achievement of all planned *outputs*, it can be verified as an actual physical state and not merely as a process that has been initiated. A common feature seen in many project proposals is statements of Purpose that are either too ambitious or can not be verified at all. For example, the phrases like;

- Up-liftment of rural poor,
- Eradication of poverty,
- Creation of employment opportunity for all,
- Greening of the Western Ghats,
- Empowerment of poor and women etc.

are considered not very specific particularly when used as a Purpose statement.

The Purposes statement should make an attempt to define clearly the extent of geographical area, specific target groups, results to be expected etc. However, in order to justify project funding, many agencies tend to select an ambitious, well-intended process-oriented project objective addressing the long-term needs of a region or the people. Such project objectives which are certainly important but difficult to achieve should, therefore, be categorized as the project Goal rather than the project Purpose.

In order to distinguish between Goal and Purpose, it is convenient to divide the project objective(s) into two parts, namely the development objective (long-term objective) and the immediate-objective. It is advantageous to accept the development objective as the Goal and the immediate objective as the Purpose of the project. An ideal project Purpose statement should

- consist of a single objective which however may have several qualifications,

- define the Target groups clearly,
- contribute at least partly to the fulfilment of the larger development objective, i.e the project Goal,
- be described as a physical state and not as a process,
- be physically verifiable.

A typical example each of Goal and Purpose statements are:

**Goal:** Sustained improvement in agricultural income of the rural population in the dryland areas of Marathawada region.

**Purpose:** Conservation, restoration and improved management of the natural resources by the communities in 5 watersheds in Marathawada region.

Some of the Outputs necessary to achieve the above Purpose are presented below:

- Fuel-wood requirements of 100 families and fodder requirements of 20 pastoral families met through plantation in 300 ha of community wastelands.
- Crop yield increased by creating irrigation facilities in 300 ha of cultivated land belonging to 200 poor and marginal farmers.
- Soil erosion reduced considerably in the non-arable lands in the upper reaches and very substantially in other cultivated lands.
- 50 families replaced low-yielding local breed cattle by high yielding cross-bred cattle.
- Communities made capable of managing their natural resources individually as well as in groups.

#### 10.3.4 Identification of Beneficiaries

A project should be designed to satisfy the needs of the identified groups. It is, therefore, necessary to first identify and categorize the stake-holders, i.e the persons, groups, sections, institutions etc. who are to be benefited from the project.

In order to identify the activities that are expected to benefit the target groups meaningfully, it is, therefore, necessary to understand the socio-cultural situations of such groups. It will, therefore, be useful to analyse the following aspects of the target groups:

- Location and distribution of the target groups.
- Livelihood pattern and traditional knowledge.
- Organizational structures both formal and traditional.
- Capabilities, attitudes and motivations.
- Interest in involvement and willingness to contribute.
- Gender, ethnicity, ownership issues etc.

It is also essential to have a clear idea about the extent of the benefits likely to accrue from the project and the method by which such benefits will be shared. For example, when community lands are brought under plantation, it is not only important to ensure that the effort succeeds but also to visualize who the beneficiaries would be and what would be the extent of such benefits.

Similarly, while analysing such problems, it is necessary to decide whose needs, interests, views etc. will be given priority. The beneficiary groups should be described unambiguously. Use of the terms like poor people, poor farmers, disadvantaged groups etc. may be acceptable for policy statements but are inadequate for project formulation. It is necessary to describe groups as clearly as possible by laying down criteria for identification, e.g

- Members of families whose total annual income from all sources is less than Rs.20,000 per annum.
- Farmers owning less than 5 hectares of dry land with no other subsidiary income.
- Members of all schedule-caste and schedule-tribe families living in a particular village/hamlet.
- The entire population of the village with priority to the poorer section.

### **10.3.5 Funding Requirements**

A request for funding is made based on the estimated cost of all the physical measures, infrastructure requirements, administration cost, techno-managerial services and operating cost during the project period, if any. The estimated cost should be as realistic as possible. It would be even better, if these could be supported with proposed designs, quantity-wise breakdowns etc. including a provision for contingency and reserve.

An attitude common to most funding agencies is an unwillingness to support infrastructure development, and a high administrative and other recurring costs. Depending upon the nature of the project, the allocation for an administrative cost to the order of 10% to 20% of the total project cost is considered in order. This tendency is justified by following an argument that a project proponent is expected to play a catalytic role in the project and not that of a beneficiary. A counter-argument often offered by many voluntary agencies is that they cannot afford to develop a reasonable level of infrastructure and maintain a high degree of managerial efficiency of their own unless supported by an external development agency.

The current trend, particularly in the case of bilateral funding, is to appoint a professional support agency on contract against payment of suitable fees for acting as a linkage between the funding and the implementing agency and also for rendering necessary techno-managerial support towards successful implementation of the project. A voluntary agency requesting for a modest project management fee towards the development of its infrastructure is therefore justified in this context and deserves favourable consideration.

The funding requirements should be broken down into smaller components, including cost of formulation, survey and studies, physical structures, administration, travel, technical services, training and workshop, monitoring, documentation, contingency etc. Availability of additional funds from other sources, expected level of contribution from the beneficiaries, savings due to innovative approaches and design should also be discussed.

It may not be possible in every situation to furnish detailed design and cost estimates of certain physical measures which will have to be decided on later in consultation with the beneficiary communities. Such limitations should be clearly



mentioned while proposing an estimated cost. An experienced funding agency will be able to make a funding allocations based on the approximate costs.

### **10.3.6 Past Experience**

A project proponent may, in its own opinion, possess all the requisite capabilities and experience required for handling the project being proposed. The funding agency, on the other hand, may not be sufficiently aware of the actual capabilities and experience of the proponent. To begin with the screening process, the funding agency usually makes efforts to assess a project proponent, in general terms, i.e in terms of its past performance, reputation enjoyed in the region of its operation, its fund-handing capability, its techno-managerial abilities etc. Before initiating the actual process of pre-funding appraisal, the basic information a funding agency would like to gather about the project proponent are its

- statutory status
- available infrastructure
- staff qualifications and experience
- fund handling capacity
- management abilities
- past experience and achievements
- general reputation/credibility enjoyed by the proponent

What lends a voluntary agency a good reputation is difficult to specify, surely, successful implementation of projects in the past does help. One effective way of sharing information on achievements of past projects is to invite members from other similar agencies to visit the works done and seek their suggestions for further improvement. Once a project is known to be very successful, people from similar ongoing projects would visit the project area on their own for enhancing their awareness and receiving training, exposure etc. The voluntary agency may also enhance its credibility by conducting experience sharing workshops, preparing useful reports, video films, and other documentation.

### **10.3.7 Project Period and Phasing**

The proposal should clearly indicate the total expected period required to achieve the stated objectives with suitable phasing, if any. Phasing may include

- Preparatory phase or inception phase
- Implementation phase I
- Mid-term corrections
- Implementation phase II
- Impact assessment
- Withdrawal and follow-up phase

A model integrated watershed management project requires a minimum of 5 years to show some results and another 5 years to consolidate the benefits accrued. A preparatory phase of about one year is considered useful for all watershed management projects. It is, therefore, worthwhile to propose to the funding agency to allow initiating a project with a preparatory phase spread over a year or so. Detail project activities, monitoring and other project management plans should be worked out during this period. The preparatory phase is also useful for rapport-building and implementation of entry programmes.

### **10.3.8 Other Requirements**

The proposal should also clearly mention additional requirements which are considered essential for successful implementation. These may include procurement of special equipment e.g computer packages, surveying equipment, solar devices, vehicles, storage facility etc. Requirements for specialized services from short-term consultants e.g gender specialist, watershed hydrologist, chartered accountant etc., should also be mentioned. It would be prudent to incorporate a budget provision in the project proposal to take care of such eventualities.

## **10.4 TECHNICAL PLAN**

Project formulation includes all relevant activities and reports prepared prior to actual initiation of implementation of a project. Several reports may have to be prepared during the formulation stage. Concept paper, project proposal, pre-funding appraisal, inception report, and project management plan etc. are some

examples. The extent of formulation activities are directly proportional to the size of the fund, demands of the funding agency and documentation capabilities of the proponent. A technical plan which may be prepared separately or as a part of any of the above reports, however, is an integral part of project formulation.

Preparation of a technical plan requires a good deal of survey and data collection. Some of the required data are such that they are not readily available and hence are to be collected by skilled personnel conducting special field surveys. Collection and analysis of data are not only necessary for preparation of the technical plan but also, later on, for implementation and monitoring. A standard Format for Resource Inventory in a watershed, useful for the preparation of a technical Plan is presented in annexure IV

How detailed a technical plan should be, before an assurance for funding is received, has always been a matter of debate. Preparation of a technically sound and socially balanced plan is a task by itself requiring a substantial amount of manpower and time extending over a few months to a year or so. Availability of a technical plan, even in a skeletal form, however, enhances the chances of project approval, facilitates fund allocation and planning for manpower requirements.

Common steps involved in the preparation of a detailed Technical Plan for a fairly large-size watershed management project are:

- Collection of secondary revenue data: *Khasra, Khatauni, Zild* etc.
- Collection of relevant reports: technical reports, district plans etc.
- Collection of maps: cadastral map, topo-sheet, wasteland maps etc.
- Collection of field data: demographic, agriculture, natural resource base, e.g land, water, plant, livestock etc.
- Reconciling secondary data with the actual field situation.
- Analysis of data and preparation of tables, texts, and graphs.
- Presentation of available data in cadastral maps: soil map, land capability map, land use map etc.
- Identification of technical measures/options and preparation of maps showing proposed land use, treatment measures, location of water harvesting structures, area for plantation etc.

- Preparation of standard design and cost estimates of the proposed measures.
- Compiling all these in a report addressing the major issues and concerns of the project to constitute a Technical Plan.

## **10.5 SIZE OF THE PROJECT**

Simple planning is likely to yield simple results which may form the basis for further development initiatives. However, the converse may not be necessarily true in the context of a watershed management project. The best of planning covering the minute details prepared by an external agency well in advance does not necessarily guarantee the best results. For this reason, it is highly desirable that both the planning and implementation be done simultaneously and by the same agency. This will help in eliminating, to a great extent, the commonly occurring but hitherto neglected planning-implementation gap.

It is not only possible but may be desirable to undertake planning (project development) in stages, using a process approach in each of the preparatory, implementation and operational stages, provided of course, the broader objective of the project is set out clear at an early stage. Preparation of a skeletal plan, taking into account the needs and priorities of different groups, is possible by conducting a few interactive discussions with the groups or using other semi-structured group mechanisms like Participatory Rural Appraisal (PRA). The project is then fine-tuned to its best in stages as implementation proceeds. The programme should begin with the components which are important but do not require a great deal of technical inputs. Specific technical designs could be developed simultaneously as the implementation proceeds.

The process approach will perhaps not be able to provide specific answers, well in advance, in quantitative terms to many questions that may be raised by the funding agencies. Since even the best of project proposals do not guarantee best of implementation, the funding agencies may consider accepting skeletal proposals for the purpose of funding and allow the project to develop as per the local needs.

However, keeping in view the requirements of the funding agencies, even in a skeletal plan, the Goal and Purpose of the project should be well defined. Other information, like the nature of Outputs to be generated, the time required for

project implementation, approximate cost, intended target groups etc. must be mentioned as clearly as possible, right from the beginning. Vagueness should be avoided and the areas of uncertainty have to be identified and stated clearly. In other words, in a skeletal proposal, while the absence of minute technical details should be accepted, but definitely not a lack of direction. This will also facilitate the much-needed process of decentralized project management which demands shifting of emphasis by the funding agency primarily from the project approval stage to the actual implementation stage under a spirit of true partnership.

## **10.6 PROJECT CONCERNS**

More often than not, a project Management Plan will dwell upon a few major development issues expecting that these will be addressed adequately while implementing the project. These concerns, depending upon whether taken seriously or not, influence project implementation one way or the other. Before a project team embarks upon the preparation of a work plan, it is important that each project staff develop a common understanding about the project objectives, priorities, concerns and the associated issues that would require addressing. Some important issues requiring conceptual clarity include:

### **10.6.1 Ownership**

Watershed Management being a land based activity generates benefit to people in direct proportion to their land holdings. Some argue that watershed development also helps the landless not only in providing increased employment as farm labours but also through creation of new opportunities. Others believe that if the interests of the landless and the poor are not specifically taken care of, such land-based development, with all its good intentions, will further reinforce the exploitative pattern of the rural land owners over the landless. Watershed implementing agency should, therefore, give special attention towards generating additional benefits for the landless and the poor through creating suitable alternative opportunities.

Another ownership issue arises while dealing with Forest lands. A large section of tribal population live and organize their livelihood from within the forest lands. They have no legal rights to the forest and its produces but have been traditionally using them. Many land based watershed development activities for these tribal are

liable to violate the existing forest laws.

Degraded Forest lands are found to form the upper reaches of many watersheds. These lands, even though are in serious state of degradation, can not be undertaken for plantation activities by any agency other than the forest department. Forest departments however, allow activities related to drainage line treatment within forest areas and are addressing this issue of afforestation through an approach known popularly as Joint Forest Management. Since the management practices for private lands, common lands and the forest lands differ substantially, the issue of land ownership must be taken into consideration while developing a watershed management plan.

### **10.6.2 Equity**

Development efforts, quite often, by-pass the vulnerable groups. For this reason, it is recommended that such groups are identified first and the equity issue be addressed both technically as well as institutionally. The most sought after common property resources in a watershed are the surface water, groundwater, revenue land and village forest. Under the prevailing social system, while the more resourceful have the access to the water resources and their own lands, Poor farmers with little land holding and the landless depend to a great extent upon the common land and the village forest for their fuel and fodder requirements. Planning of a watershed development project should, therefore, make a conscious effort to promote a mechanism for equitable sharing of the existing and developed common resources.

Thus, the use of the benefits created by the project like water stored in a water harvesting structure or the *usufructs* generated from plantation in common lands should be planned in such a way that the benefits are shared as equitably as possible giving greater preference to the disadvantaged groups. Conservation and restoration of the degraded natural resources while providing benefits to the poor, is a challenging task. Certain compromises are to be resorted to and solution to larger problems are to be worked out jointly in a longer time frame. The concepts of *Pani Panchayat* and *Van Panchayat* etc. have been proved to be useful in this context.

At times, the issue of equity is addressed through the concept of inter-dependance. Under this concept indirect benefits are provided to those communities which can not receive project benefits directly. For example, in order to benefit the pastoral communities, the project may introduce a system, where grasses grown in the common lands will be collected free of cost and on priority basis by the members of this community.

### **10.6.3 Gender**

The term gender rather than women is used to emphasise that the problems of women are primarily due to gender discrepancy rather than the biological difference. Gender is a much larger issue and is beyond the scope of this chapter. In the context of natural resource management, the gender related issues are quite focussed and viewed under the existing socio-economic perspective.

When the natural resource base start degrading, the poorer communities who depends directly upon these resources are affected first. Amongst the poor, the women and the children face the direct consequences of resource depletion which are manifested, amongst others, by increased drudgery and malnutrition. While planning and implementing watershed management projects, attention must, therefore, be focussed on the problems of drudgery of the rural women in general and of those from the poorer families who are actually involved in collection of fuel wood, fodder and drinking water, in particular. The project team has to devote special attention in reducing the drudgery and improving the role and status of women. This is achieved to some extent by ensuring that the women from the affected groups get an opportunity to voice their opinions and participate in decision making process while the project is being implemented.

In order to identify the constraints associated with village women, it is recommended that the following aspects should be evaluated and incorporated into the planning and implementation processes.

- Access to natural resources, their quantity, quality, distance etc.
- The possible impacts of the proposed project activities on women.
- Gender relationship in the village.
- Capacity of women in general and how capacity building can help.

- Role of women in participatory planning, decision making etc.
- Forum available for women for meeting and sharing their common concerns.

Watershed development offers sufficient opportunities to organise the village women and to address some of their identified needs. Formation of women's functional groups around a set of activities under watershed management projects, so far has yielded encouraging results. The same applies to other income generating activities through self help groups (SHG) for women. These activities need to be strengthened further, keeping the given socio-cultural realities of the project area in view.

#### **10.6.4 Environmental Concerns**

It is well known that lack of awareness and the pressure of an increasing population have been depleting the non-renewable natural resources irrevocably and the renewable resources at a much faster rate than it can recoup naturally. This has given rise to the concern for adopting long term development strategies whereby the needs of the present generation are met without degrading the environment too much so that the future generations can also meet their needs. Concerns for environment is going to play a more and more dominating role in designing future development projects. If the adverse environmental impacts of development projects are not taken care of well in advance, new environmental problems will be created giving rise to a situation where yesterday's solution will be today's problem.

Environment and poverty are also related in a simple cause-effect relationship. It is the poorer section who depends directly on the common natural resources and also contributes maximum to the cause of their degradation. The depletion of common natural resource base in turn become the cause for greater poverty. Unless intervened through conservation and management, the cycle of poverty and degradation continues in an expanding spiral.

Watershed management projects aim to conserve, restore and manage the natural resources. The entire approach is based on the assumption that natural resources are to be conserved and restored and at the same time increased utilization will be possible through increased productivity and management. Any activity that would



further degrade the environment will affect the long term objective of watershed management which is sustainable development of the natural resources.

## **10.7 NEED ASSESSMENT**

Identification of the needs and priorities of the communities (target groups) is considered the most important pre-requisite for developing a meaningful project proposal. People, however, are likely to have a series of needs and priorities which may or may not have any relevance to the programme at hand. The needs may include village infrastructure like roads, schools, hospitals, electricity, post office etc. Personal benefits like government service, waiving of bank loans, increase in subsidy, reduction in input costs, free irrigation wells, pump sets etc. may also be in the list. People appear to organize their needs according to what they perceive the external agency is capable of providing as per the expressed intentions of the project.

However, when people are asked about what development projects they could plan and implement with their own resources for managing their own land, water, animal and crop their needs and priorities gradually start focusing on aspects of natural resource management. Being concerned with his individual problems, a common villager may not always be in a position to readily understand the underlying concepts of integrated watershed management. Certain discussions are therefore necessary to make people understand the causes for the existing degradation in the natural resources base steps to be taken to improve the situation.

## **10.8 RESOURCE INVENTORY**

Resource inventory includes collection of data on the existing status of the natural resource base - land, water, crops, vegetation, livestock, their distribution, ownership, utilization pattern etc. In order to formulate a meaningful project proposal, it is also necessary to evaluate the socio-economic dimensions of the people in the project area in quantitative terms. This is achieved by collecting and analysing socio-economic data covering the people, their economic status, agricultural practices, livelihood pattern, available resources, related assets and liabilities. Apart from providing sufficient information, this data base also serves as a baseline against which future progress of the project may be compared for

evaluating the impact of project implementation.

Some of the required information is gathered from secondary data sources, i.e. those data which have already been collected by others and are available for use. The reliability of the secondary data needs to be properly assessed prior to any analytical use. Case-specific data collected directly by the user for a specific purpose are the primary data.

Information considered useful in formulating a natural resource management project and hence collected by most agencies, to the extent possible, are listed below.

#### **A. *General***

- *Area*: areal extent, physiography, rainfall, other climatic conditions etc.
- *Demography*: Gender and caste distribution, family size, literacy rate etc.
- Distribution of farmers to non-farming working population.
- Groups with various traditional skills.
- Nearness of urban centres and employment opportunities; migration, if any.

#### **B. *Amenities and Infrastructure***

- Availability of drinking water, electricity.
- Prevalence of diseases and health services.
- *Environmental sanitation*: latrines, compost pits, drains.
- *Educational institutions*: primary, middle, higher, technical.
- Distance from market, post office, bank, financial institute, block office.
- Roads, transport and communication.
- Processing and preservation facilities.
- *Village Institutions*: Cooperatives, producers' union, societies, clubs.

#### **C. *Hydrology***

- *Rivulets and Streams*: Number of streams, their width, length, period of flow, existing harvesting structures, present utilization, average seasonal

discharge.

- *Tanks*: Number, size, utilization, present state, maintenance system.
- *Wells*: Number, average depth, pre- and post-monsoon water levels, pumps used and total pumping hours, area irrigated.

#### **D. *Land use***

- *Land use pattern*: Area under cultivation, fallow, culturable waste, forest, habitation, unculturable waste, hills and water bodies.
- *Land ownership*: Private land, encroached land, *patta* land, *gram sabha* land, forest land.
- *Land Capability Class*: Soil depth, land slope, erosion, other limitations.

#### **E. *Agriculture***

- *Land holdings*: Size wise, caste wise, number of *patta* holders and landless individuals.
- *Irrigation*: Extent, source, application methods.
- *Cultivation Practices*: Cropping pattern, crop yields, use of crop residues, seeds, fertilizers, tools and implements in use.
- Habits in homestead cultivation.

#### **F. *Livestock***

- Types of animals, breed.
- Productivity and utility.
- Availability of feed and fodder.
- Health care and insurance.
- Marketing of the produce.

#### **G. *Plantation***

- *Types of vegetation*: Trees, shrubs, grasses, their occurrence, distribution, density and use.
- *Ownership*: Private, Panchayat, road side, forest department.

- Preference of species by the communities.
- *Scope for plantation*: Class of land, ownership, purpose.
- Availability of seeds and biogenetic material for propagation.

An inventory of natural resource base, particularly of the water resource, must however, be carried out by experienced personnel with necessary subject specific knowledge.

## **10.9 SOCIO-ECONOMIC SURVEY**

Socio-economic surveys cover collection of information on sources of earning , expenditure, relevant social habits, livelihood patterns etc. A broad-based socio-economic survey also fulfils, to a large extent, the purpose of a resource inventory. A direct method of collecting reliable information about each family in a village is to conduct a door-to-door survey using a simple but effective questionnaire prepared for this purpose. Information about the village infrastructure should be collected in one sitting with a group of villagers having representation from all sections of the village communities.

### **10.9.1 Approach**

Records of basic data of each village are usually maintained in the Block office. These data may or may not be dependable or up to date. These data are, however, useful in planning a socio-economic survey as they provide more than a rough idea about a village. Before initiating survey work, the surveyors should also be reasonably informed about the socio-cultural features of the area, e.g local dialects, festivals, cropping and harvesting seasons, time when heads of families are available, common apprehensions of the villagers based on their past experience etc.

Designing an all-pervading long questionnaire does not necessarily lead to collection of quality data. The quality of an effective survey will depend both on designing a case-specific, interactive questionnaire and also on the credibility of the surveyor. An interactive questionnaire helps in bringing about a certain amount of awareness amongst the respondents. Holding a village meeting before commencing survey work is essential to ensure that the villagers become aware of

the purpose of the survey. The interviewer, during the survey, may have to explain further the purpose of the survey but should not make any irresponsible promises or criticize other persons. While carrying out the survey, it would be useful if the interviewer would keep in mind the guidelines set out below.

- The interviewer should have the skill to adopt the local dialect.
- Questions should be asked as a matter of conversation, not in an investigative manner.
- The interviewer should not make assumptions about the family or the household and prompt or assume any answers.
- Doubtful information should be cross-checked from time to time during the discussion.
- The interviewer must meet the convenience regarding respondent's time and date for the interview rather than his own.
- To avoid collection of misleading or incomplete information, the respondent should preferably be the de facto head of the family.
- An arrogant or unwilling respondent should be dropped from the survey, only if sufficient explanations fail to persuade him to cooperate.

The questionnaire used should be simple and the interview should not last more than an hour. The entire proceedings should be conducted informally. The questionnaire should be used more as a guideline and a means rather than an end. While the interviewer should not insist on an answer to a question which the respondent does not wish to provide, all positive feedbacks provided voluntarily by the respondent should be noted. Many information gaps can be filled by an experienced interviewer through objective observation of living conditions of and crops grown, cattle owned etc. by the respondent.

Social data or socio-economic data collected through a properly designed questionnaire can bring out not only the socio-economic profile of communities but also bring out the existing variations from one group to another within the communities. Details of village infrastructure should be collected separately, using another questionnaire which should be designed to suit the local interests and conditions.

## **10.9.2 Design**

Carrying out a full-fledged socio-economic survey is both time consuming and expensive. It is also not an easy task to segregate which data have a direct significance for project formulation and which will serve as baseline data to be used later for monitoring and evaluation. In addition, quite often, large numbers of data collected at the cost of substantial expenditure are found to be only of marginal use in the overall context of the project. Many a time, it may not be possible or practical to carry out such a survey covering a very large population. To reduce the strain on available resources and at the same time gather sufficient information useful for project formulation, a *stratified random sample survey* has been found to be helpful.

In a stratified random sample survey, the entire population is first stratified into different groups based on certain socio-economic criteria, e.g caste, occupation, ownership of a certain type of asset etc. An equal number of representative individuals or households are then selected randomly for survey from each category. The sample data collected from each group are later extrapolated for the entire village. A standard questionnaire for conducting family-level socio-economic surveys useful for formulating a watershed management project is presented in the Annexure III.

An elaborately conducted socio-economic survey increases the level of expectations amongst the local communities. It is often a dilemma to decide whether to conduct a detailed socio-economic survey at the beginning of the formulation stage (pre-funding stage) or postpone the task till when the implementation strategies are to be worked out (post-funding stage). Certain basic information, will, in any case will be necessary for the purpose of project formulation. It would, therefore, be an advantage, if certain basic data are collected quickly in consultation with the village Sarpanch (preferably the ex-Sarpanch) supported by other knowledgeable persons from the village.

## **10.10 PARTICIPATORY RURAL APPRAISAL**

An alternative approach to data collection which claims to replace, to a large extent, the need for carrying out a socio-economic survey, is to conduct

Participatory Rural Appraisal (PRA). PRA which is basically a participatory planning tool, also generates basic information which has a direct use in the formulation of a skeletal project plan. While a socio-economic survey generates quantitative data, PRA generates qualitative information.

### **10.10.1 Genesis**

Evolving initially around 1979 as Rapid Rural Appraisal in the Institute of Development Studies, University of Sussex, UK, the approach has since become a widely accepted methodology for almost all development projects in India. Rapid Rural Appraisal, as the name suggests, is a method of finding out quickly certain information necessary for project formulation from communities with whom communication through a common language is not very easy. Consequently, a typical communication methodology, using leaves, twigs, stones, sketches on the ground etc. was adopted to develop a project proposal jointly with the communities involved. Participatory Rural Appraisal (PRA) began to evolve around the late 1980s in the course of a search for planning approaches that could support decentralized planning, democratic decision-making, value social diversity, work towards sustainability, and enhance community participation and empowerment. Participatory planning with people is not a new concept. Development efforts had always been evolving around the beneficiary groups with the intent of involving them in projects, in one way or another. Participatory Rural Appraisal has been described as a method that enables the local people to share, enhance and analyse their knowledge, to plan and act. This method permits going ahead with the process of project formulation even where basic data are hardly available and adequate communication between the project workers and the communities through a common language is difficult. The approach in PRA can be described as a semi-structured way of learning relatively quickly from local people about the key problems and opportunities of an area and of deciding on an agreed set of possibilities for alleviating the problems and/or making good use of the opportunities (Chamber, R., 1991).

The general objective of PRA is to involve rural communities in the village-level planning process by making them aware of the existing constraints and opportunities. Attempts are made to infuse a self-help attitude amongst the people. The process also helps in establishing rapport between the villagers and the PRA

team members, who may eventually also be the project implementing staff. The specific objectives will depend upon the specific purpose for which the PRA is conducted, e.g watershed management, family planning. According to the proponents of the methodology, a PRA exercise should necessarily bring out first-hand, up-to-date and reliable information which should be considered as a most authentic record of people's views.

### **10.10.2 Preparation**

PRA is an organized yet open-ended method which unlike a questionnaire-based survey does not emphasize quantification of information (data). It allows collection of relative-status of information, i.e. comparing, grading, ranking, scoring, trend studies etc. Preparation of watershed management plan demands a quick and realistic appraisal of local conditions such as natural resource base, access and utilization pattern of these resources and an analysis of cause and effect relationships, inter-relationship amongst different interest-groups etc. Such information is useful, enabling the allotment of priorities, through an alternative analysis, to the solution of problems. The method, when applied with sufficient effort, can help in the preparation of a skeletal Village Resource Management Plan (VRMP) with adequate participation of the communities.

According to the recommended procedure (Chambers, 1981), PRA should be carried out for the whole village by a multi-disciplinary team comprising of one team leader and 4-5 subject-matter specialists. After the first introductory meeting, one or two experts are allocated the task of carrying out separate interviews with selected groups on subjects of their expertise. The team members should make conscious efforts to explore, observe, watch, learn and remain free from preconceived notions. The team members should give daily feedback to the team leader and receive daily debriefing. All the findings are then organized and shared with the villagers in a larger meeting. This follows a brainstorming session leading to ranking of priorities in consultation with the selected groups. This information is then used to prepare the necessary village development plans. A PRA exercise to develop a village level development plan should ideally be conducted over a period of five days.

The PRA team should have some female members who could give special



attention to the problems of the village women. Attempts should also be made to use the services of independent key informants, e.g schoolteacher, youth leaders, vocal elderly women, etc. present in the village. Team members should also be able to locate the self-appointed local leaders, traders, contractors etc. and judge their potential role in the PRA process.

In order to conduct an effective PRA, it is important that adequate preparations be made in advance. The attitude and expertise of the team members are the most critical input. The team members should have a well-developed capacity to listen and understand the problems as visualized by the village communities. They must refrain from giving lectures and offering readymade solutions. The idea is to facilitate the process of people analysing their problems and arriving at a common solution by themselves. Conducted mechanically, a PRA exercise would not generate the desired results.

PRA begins with a semi-structured approach but, in its attempt to remain holistic, it has to allow inclusion of unexpected or unrelated issues or topics that may crop up during the discussions. Consequently, a PRA may generate a great deal of information which may not have direct relevance to the project under consideration. Unless this information is synthesized and correlated to focus in a particular direction, the resulting insight may be too broad to have any immediate use. It is, therefore, important that the purpose of a PRA exercise be kept clearly in the mind so that the flexible, exploratory, interactive, inventive approaches do not convert the entire activity into a free for all session serving no useful purpose.

### **10.10.3 Data Collection**

Before beginning a PRA exercise, it is important that as much secondary data as possible be collected from both published and unpublished sources about the area and the people. A basic understanding of local conditions will enable the PRA team to address the problems and opportunities in the right perspective. PRA attempts to collect primary data with a data optimization approach, i.e. limited data which are obtained inexpensively but are expected to produce results. The data collected are not to be used for any scientific analysis but should be dependable enough to enable formulation of a flexible project proposal with clear ideas on priorities.

Quite a few publications are available which deal with the application of PRA as a technique and also suggest methods of collection and presentation of useful data. Typical types of data usually collected during a full-fledged PRA exercise are discussed below .

### **A. *Spatial data***

These are data related to the physical conditions of the locations under consideration. Village maps, resource mapping, transect diagrams and all kinds of other sketches and illustrations which visually depict the layout, quality and relationships amongst the various resource bases in and around the village are spatial data. Sketches or models may be prepared to highlight the relationships amongst hills, water and forest; between over-grazing and land degradation; between soil condition and crop production, etc. These sketches (or models) are used by the groups to approach the problems from a spatial point of view and decide on proposed measures for improvements.

Cadastral maps or topo-sheets or even satellite imageries may be used to study the important features of the village. Simple maps may also be drawn on the ground using coloured powders for every one to see and participate in the discussions. The effectiveness of these maps is not reduced even if they are not prepared to scale. These models or the maps are then used frequently during the subsequent discussions. The maps are slowly improved upon through additions of proposed measures. The proposed measures marked on the map provide everybody a chance to offer their response to the proposals.

Transects are plots of rough surface profiles drawn along a linear distance covering the area. The profile of the existing surface slope is first drawn along a selected straight line. Important physical features like forest, sources of water, streams, type of soil, agricultural land, roads, buildings, habitations and other land use as they actually occur along the line are drawn using suitable symbols. A transect line could be selected in any desired direction across the village, e.g north to south, east to west, highest point to the lowest point etc. A transect profile drawn along the highest to the lowest elevation may easily be divided into three distinct zones, viz. highly sloping land, moderately sloping land, and flat land.

## **B. *Time related data***

Time related information is presented through time lines, trend line, seasonal calendars etc. A time line is a chronological list of key events in the history of the community which goes back to the limit of the memory of the eldest inhabitant of the area. The list identifies past trends, events, problems and achievements. The time line helps the PRA team to understand the pace of events and also events that are considered important by the people. This particular form of information gathering is bit time-consuming and the community needs help to relate the years of the happenings since many rural communities are poor in remembering calendar years. Activities like years of settlements, drought, epidemics, famines, natural disasters, floods, introduction of school, electricity, irrigation, tube wells, pump sets etc. are some of the events of common interest.

The trend line attempts to note the trend in changes that had taken place in the village with respect to a particular resource position. It is helpful to understand the perception of significant changes in the community over time. The trend in changes like that of water flow, forest cover, cattle population, soil fertility, tree cover, land use, fertilizer use etc. are a few examples. The PRA team can learn from the community how it views these changes and to what causes they attribute the occurrence of these changes.

A seasonal calendar attempts to establish a regular cycle or pattern of activities that recur within the community within a year. A seasonal calendar permits presentation of a large number of diverse items of information in a common time frame. It provides information on the times of sowing and harvesting, availability or non-availability of labour, water, fodder, fuel wood etc., time for common diseases, food shortage, migration etc. The pattern may however differ from community to community in the same area (village).

## **C. *Ranking***

Ranking involves listing or categorizing a given entity in a definite order. Ranking applies to problems, priorities, dimensions, degrees etc. as visualized by different communities and is considered a very important outcome of PRA. Since funds,

manpower, infrastructure and other resources are limited, development plans must identify priorities. Certain basic needs are identified and discussed thoroughly with the communities. This helps the communities in understanding the constraints and opportunities and facilitates acceptance by them of certain priorities for long-term and overall community interest against those of individuals.

Ranking is done on selected topics with selected groups using locally accepted criteria for qualitative descriptions, e.g big, medium, small or excellent, good, bad etc. Ranking may be done on wealth, landholding, caste hierarchy, environmental degradation, soil conditions, choice of livestock, tree species, crops, trades, skills etc. Besides giving a common perspective on each problem and the associated opportunity, ranking helps in developing a village resource management plan. Ranking presented in a tabular form is known as a ranking matrix. An example of a typical ranking matrix for choice of tree species that may be developed through a focused group discussions is presented in Table 10.1

Tree	Use				Ranking of preference
	Fuel	Fodder	Fruit	Timber	
Eucalyptus				X	6
Subabul	XX	XX	X		5
Neem	X	X	X	X	1
Ber	X	X	XX	X	3
Mango			XX		2
Seesam	X			XX	4
Prosopis J.	XX		X	X	7
Acacia	XX			X	8

**Table 10.1 A ranking table for selection of tree species.** *Note:* xx is the primary use and x is the secondary use.

The ranking in the table is based on the use of the species under consideration. Other parameters like soil improving capacity, growth rate, ease in propagation etc. may also be included in the ranking table. One ranking technique is wealth ranking. Instead of going into the actual income of an individual household, a comparison is made between two households to get an insight into relative poverty in the entire village.

During the course of PRA, once clear-cut priorities on specific areas emerge, attempts should be made to collect more data on the subject. For example, if it is clear, half way through, that people desire irrigation projects, the PRA team may concentrate on collecting information on factors like rainfall, flow pattern in the stream, average depth and yield of wells, source of power for lifting etc. These could easily be covered when the PRA team consists of subject specialists from water, agriculture, livestock, forestry etc.

#### **D. *Other techniques***

Several innovative techniques may be adopted to draw out information from the people and also to share information with them. Hierarchy and interrelationships amongst various local institutions are discussed using local material like circular paper cut-outs of different sizes, following what is known as *venn diagram*. A venn diagram is a tool usually used in mathematical *set theory*. A set of parameters is represented through a circle. The area of intersection of two circles represent common items occurring in each set (circle). Thus two partially overlapped circles will be used to indicate to the farmers, the presence of common factors. The larger circular cut-outs represent the larger organizations. The distance maintained between two circles (organizations) represents their closeness in relationship. Such diagrams are used to indicate, the relative importance of different existing resources and institutions e.g block office, district town, market, veterinary centre, hospital, police station, bank, project office etc. Venn diagrams help villagers to visualize the organizational interrelationship which is conventionally represented in literature as block diagram.

#### **10.10.4 Expected Outcome**

The PRA exercise must not end up in generating a long list of what people want. It should help people to analyse their problems by themselves and help them in developing a self-help attitude in addressing them with their own efforts. Consolidation of the various discussions held with the communities is best done by preparing a village resources management plan (VRMP). Preparation of such a document serves a variety of purposes. It becomes an authentic record of the aspirations and priorities of the communities which may be used for improvement in the implementation strategy. A successful PRA can bring out specific

recommendations on all or some of the following aspects of project management.

- Developmental priorities as agreed by the communities.
- Preparation of an action plan and mode of implementation.
- Identification of inputs which the community will require from external sources.
- Commitments on duties, responsibilities, contributions from individuals and groups.
- Structure and activities of the peoples' institution to be established to implement and manage the project.

### **10.10.5 Indian Experience**

In India, as the PRA techniques are being applied with several modifications by many NGOs and State Government departments, wide ranging experiences have already been gathered. The prime concern about these modifications is that the term PRA is being loosely used by most practitioners. Any group discussion conducted with villagers is readily being described as PRA activity. Modified PRA approaches have subsequently been described using terms like Participatory Learning Method (PALM), Participatory Planning for Watershed Development (PPWD) etc. Some would even like to expand PRA as Participatory Rapid Appraisal, giving more emphasis on rapidity than on participation. According to MYRADA, a NGO, which has been applying extensive PRA techniques in watershed management projects in Karnataka, PRA offers as much in terms of learning opportunities to the participating development workers as in identifying the needs and priorities of the people. It offers a glimpse of the village realities, social complexities and mind-set of the village communities. There is also the possibility that these acquired insights may convert some development workers into well-informed sceptics concerning the whole top-down approach of development initiatives.

Unless a PRA is conducted at its ideal level of perfection, it is difficult to gauge the effects it will leave behind in the minds of the villager who participate in it. Conducted without sufficient conviction and preparation or under compulsion, a PRA exercise may be viewed by the village people as a street drama which

nevertheless is entertaining. PRA may not be very effective if the credibility of the team members is not accepted by the larger sections of the village communities. Conducting a PRA in a village without much rapport is likely to be neither effective nor desirable. For this reason, it may be advantageous to conduct PRA only after a certain minimum level of rapport has been established. This is best achieved during the implementation of the entry programmes in the village. As PRA increases the level of expectations, it is also necessary to ensure that PRA activity is actually followed up with a viable project proposal.

If PRA is conducted for need assessment alone, it may simply result in the generation of a long list of what the people would like the implementing agency to do. An ideal PRA is expected to make people aware of their problems, stimulate them to think of solutions, prepare an action plan, allocate responsibilities, decide on contributions etc. Ideally, PRA is not a one-time activity. A series of honest discussions and village meetings spread over the entire project period will enhance participation much more than a one time PRA conducted with all its associated festivities.

Another emerging need is to make a clear distinction between the application and purpose of PRA and those of RRA (Chambers and Irene, 1995). The usefulness of PRA during the formulation and implementation stages should be probed. While RRA may be more useful during the formulation stage for resource mapping and identifying meaningful programme components quickly, PRA has greater use in the implementation stage. PRA may also be used for conflict resolution and trade-offs amongst different groups and communities. There is also a need to give sufficient attention to how the aspirations of the people will actually be converted into a physical reality. The role the subject specialists are required to play in this regard also needs clarity and must not be undermined due to over-enthusiasm or wishful thinking.

## ***11.0 Appraisal of Project Proposal***

---

### **11.1 ASSESSMENT OF PROJECT PROPONENT**

This is one of the most crucial aspect of pre-funding appraisal and thereby is also the most difficult task. While considering a proposal, attempts are made to critically evaluate the aspects of integrity, reliability, credibility, capability etc. of the proposing agency. The objective is obviously to ensure that the funds provided are utilized judiciously and efficiently for project implementation. In order to gather a basic impression about the project proponent, attentions are focussed on the following aspects:

- Statutory requirements e.g registrations, governing body, chief functionary, size and location of office etc.
- Staff structure, their qualifications and experiences.
- Available infrastructure.
- Fund handling capacity.
- Project management capability.
- Source of funding of the earlier projects.Past experience and performances with similar projects.
- Reputation and relationships enjoyed with other local agencies.

An impression about a project proponent can also be gathered by seeking information from other funding agencies who had funded the proponent in the past. Such information, however, could be highly subjective in nature and must be used with sufficient objectivity basically for the sake of a first impression. After being satisfied, prima facie, on the information so received, a visit is necessary to the project area to discuss various aspects of the proposal with the chief functionary as well with other project staff and some members of the proposed target groups.

The integrity of the project proponent may be assessed by looking into the functioning of the organization, leadership profile of the chief functionary and the democratic process the agency follows. Credibility may be assessed from the level



of motivation shared by the staff, degree of frankness in their opinions and reputations enjoyed by the organization amongst the local beneficiaries where projects have already been implemented in the past. Capability of the organization is normally assessed by studying the staff structure, their qualifications, experiences and quality of work executed in other projects. The fund handling capacity is assessed by studying the audited statement of accounts for the past few (three) years. Overall reputation enjoyed by the proponent may be obtained by making casual queries about the organization with some selected local people. It may not serve any useful purpose to seek feed back from other development agencies (competitor) involved in implementing similar projects in the region. A standard but effective format to assess a voluntary agency for the purpose of pre-funding screening is presented in the annexure II.

## **11.2 PROJECT APPRAISAL**

All projects are approved based on a pre-funding appraisal. The extent of such appraisal depends upon the size of the project and availability of resources. A funding agency that funds a large number of small projects and is not in a position to monitor these with equal attention, usually attach high priority to one time pre-funding appraisal before making a decision for funding. This is normally followed by introducing several procedural checks and balances to ensure proper utilization of the funds. For large projects, considerable amount of time and resources are spent in its pre-funding appraisal and also in monitoring during implementation and evaluation by the end of the project.

Pre-funding appraisal of a project proposal is conducted either directly by the funding agency or through a group of specialist(s) identified for this purpose. The prime concerns of pre-funding appraisal are to evaluate the justification of the project proposal and assessment of the capabilities of the project proponent in delivering the proposed results. In order to reduce the subjectivity and personal biases in an appraisal report, usually a Terms of Reference (TOR) is prepared raising a series of questions or concerns, which the appraisal team is required to address. Project appraisal begins by making a visit to the proposed project area and undertaking detail discussions with the project proponent. Discussions may also be held with the some of the members from identified target groups and other development agencies working in the area. The pre-funding appraisal report for a

large project, prepared after using sufficient resources and efforts, is also referred commonly as *Project Formulation Report*.

Pre-funding project appraisal in its broader sense refers to the process of identifying, defining and quantifying the proposed actions and their possible impacts on the people and the area. Some of the impacts resulting from these actions will be seen as benefits while others will be seen as costs. Pre-funding appraisal will be required to make a judicious assessment of both and provide the recommendations. Some common aspects, amongst others, that are looked into with greater detail are the technical feasibility, economic viability, social desirability and potential environmental impacts of the proposal.

### **11.3 TECHNICAL FEASIBILITY**

The purpose of assessing the technical feasibility of a project proposal is obviously to ensure that the proposed technical solutions are acceptable to the local communities and will indeed solve the problems under consideration. Evaluation of technical feasibility thus include looking into the potential of the proposed physical measures to solve the problems, their estimated cost, suitability of the site conditions, ease in operation and maintenance etc.

Technologies associated with watershed management often, offer a degree of flexibility in their application and allow use of quite a few alternatives depending upon the adopted project strategy. Sometimes, in order to benefit a specific disadvantaged group, compromises are made in the criteria for site selection and also in the cost norms. This is all the more applicable when quite a few, more or less similar technically feasible sites are available for a particular development measure. At times, even a relatively less technically feasible site may be accepted after balancing the limitations against the benefits to be accrued to the identified target group.

In watershed management, as the implementation proceeds, there remains a possibility for considering alternatives technology or improvise upon what had been proposed initially. Such modifications, however, should be incorporated only after sufficient discussions with the technical specialists and the intended beneficiaries. Though, the technical feasibility is not a limiting consideration for

designing the physical measures, but nevertheless, the aspect of site feasibility must not be undermined, otherwise the project despite of being successfully implemented may fail to yield the expected benefits.

#### **11.4 ECONOMIC VIABILITY**

There is need to differentiate between the economic viability of a project from its financial viability. Financial viability determines desirability from benefit-cost efficiency point of view. This deals with cost and returns from the project with special reference to the target groups. Economically efficient projects are those which add to the society as a whole and thus to the National income e.g conservation projects. Thus, while a conservation project is economically highly desirable but financially it may not satisfy the viability norms.

In reality, it may not be easy to clearly identify a development project as completely viable or unviable from both economical and financial points of view. There would always be certain valid arguments in favour and against the justification of a project. Since not many readily applicable norms are available as yet, for valuation of the natural resources in monetary terms, ascertaining economic viability of a natural resource conservation project in no uncertain terms, is a difficult task. This renders economic analysis of a project subjective in nature. However, a questionnaire based evaluation technique known as the *Contingent Valuation Technique* has been found useful in quantifying the value of the benefits derived from the use of a Natural Resource by ascertaining the *willingness to pay* (WTP) for the benefit by the traditional users.

The common approach in economic analysis is to compare the benefits and costs in their right perspectives. Cost (negative impact) will include any decrease in the quality and quantity of such goods or increase in their price. Benefits (positive impact) will either be the increase in the quality and quantity of goods that generate positive utility or a reduction in price at which they are supplied. Benefits are also defined relative to their effects on the improvement in human well being. Costs are sometimes defined in terms of their opportunity cost, which is the benefit foregone by not using these resources. Watershed development projects have both tangible and intangible benefits.

### **11.4.1 Benefit-Cost Analysis**

The most popular method of ascertaining the financial viability of a project is to analyse the benefit-cost ratio or computing the Internal Rate of Return (IRR) of the project under consideration. While computing the benefit-cost ratio, the prime consideration is that while the cost is incurred at present, the actual benefits are obtained in the future. For a realistic comparison, all the future benefits to be accrued annually through out the productive life of the project are reduced to their present value by multiplying each annuity with a corresponding discounting factor which is given by.

$$\text{Discount Factor} = 1/(1 + i)^n$$

Where,

i = Interest rate

n = Project life

If a project is expected to give a fixed return every year for say n years then the cumulative discount factor for the entire n years can be computed from the following formula.

$$\text{Cumulative discount Factor} = [(1 + i)^n - 1] / [i (1+i)^n]$$

A project is said to be financially viable if the ratio of the present (discounted) value of total future benefit and total cost is found greater than 1. Higher the benefit-cost ratio, higher is the financial viability of a project.

### **11.4.2 Limitation of Benefit-Cost analysis**

Comparison between benefits and costs are generally based on price. But in the real world specially in the developing countries, price of many commodities usually do not reflect the mechanism of supply and demand. some distortion in the price system normally occurs. e.g subsidy provided or the interest rate controlled by the Government. These distortions make appraisal of social or economic merit of a project based on actual prices both incomplete and inaccurate.

It is, however, possible to adjust market prices to the level of "equilibrium prices" to equalize supply and demand which are known as *shadow price* or *accounting price*. Theoretically, when shadow prices are substituted for market price, cost and benefits expressed in market prices can be compared to quantities which give their real economic value, thereby making it possible to compare projects. This way however a project which gives high returns on the basis of market price may be shown to yield a low or even negative return in real terms and *vice versa*.

Since, the anticipated benefit of any project is based on several assumptions, the most important question in benefit-cost analysis is whether to apply the test in the beginning, in the middle or at the end of the project. While the benefit-cost ratio computed in the beginning of a project gives a theoretical value based on theoretical benefits, the one conducted at the end of the project gives the actual value. Carrying a benefit-cost analysis in the middle of the project may be more realistic.

Another limitation in applying the benefit-cost analysis arises from our inability to ascertain the monetary value of indirect benefits e.g. reduced pollution, improved environment, increased drinking water etc. Projects which are socially profitable but do not satisfy the conventional benefit-cost analysis e.g. conservation projects may, therefore, be considered for public interest as a matter of public policy. Benefit-Cost analysis, however, helps in keeping under check those social welfare projects which neither generate the welfare nor the profits.

### ***Problem 11.1***

*An irrigation project based on check dam cum lift scheme is to be installed at cost of Rs. 3,50,000 out of which Rs. 1,20,000 will be spent by the end of first year and Rs. 1,30,000 by the end of second year. Actual lift irrigation will begin from 3rd year onwards giving an expected benefit of Rs. 90,000 per year from sale of crops. Find the benefit-cost ratio of the project if the prevailing interest rate is 15% per annum and the effective life of the project is 12 years. The annual operating cost of the scheme is expected to be Rs.12,500 for the first 5 years, Rs. 15,000 for the subsequent 3 years and Rs. 20,000 for the last 2 years.*

### Solution 11.1

Yr	Cost in Rs. '000					Benefit in Rs. '000		
	Cap. Cost	O&M Cost	Total Cost	D.F @ 15%	Present Value of Cost	Net benefit	D.F @ 15%	Present Value of benefit
1	120	-	120	0.869	104.280	-	-	-
2	130	-	130	0.756	98.280	-	-	-
3	-	12.5	12.5	0.657	8.2125	90.0	0.657	59.13
4	-	12.5	12.5	0.571	7.1375	90.0	0.571	51.39
5	-	12.5	12.5	0.497	6.2125	90.0	0.497	44.73
6	-	12.5	12.5	0.432	5.4000	90.0	0.432	38.88
7	-	12.5	12.5	0.375	4.7000	90.0	0.376	33.84
8	-	15.0	15.0	0.327	4.9000	90.0	0.327	29.43
9	-	15.0	15.0	0.284	4.2600	90.0	0.284	25.56
10	-	15.0	15.0	0.247	3.7050	90.0	0.247	22.23
11	-	20.0	20.0	0.215	4.3000	90.0	0.215	19.35
12	-	20.0	20.0	0.187	3.7400	90.0	0.187	16.83
Tot	250	1475	3975	5.419	2551.27	900.0	3.793	5964.97

Note: Salvage value of the hardware on the 13th year is ignored

Therefore,

$\text{Benefit/Cost ratio} = 5964970/2551270 = 2.338$ , The project proposal is financially viable.

Computing Internal Rate of Return (IRR) of a project follows a similar concept. IRR is that break even annual return in percent that yields a benefit-cost ratio equals to 1. For a project to be viable, its IRR should be greater than the prevailing market interest rate (i). The IRR of a project is obtained by trial and error method as cited below.

### Problem 11.2

Total cost of a check dam cum lift scheme is Rs. 3,00,000. The anticipated life of the scheme is 20 years. The scheme is expected to give a return of Rs. 50,000 per

year from the very first year. Find the Internal Rate of Return (IRR) of the project and judge if the project will be profitable when the prevailing interest rate is 20% per annum.

### **Solution 11.2**

The IRR is normally computed by trial and error method assuming different interest rates as enumerated in the table below.

<b>Interest rate %</b>	<b>Cumulative D.F for 20 yrs</b>	<b>Net benefit per year, Rs</b>	<b>Present Value of benefit, Rs</b>
10	8.5136	50,000	4,25,680
11	7.9633	50,000	3,98,165
12	7.4694	50,000	3,73,470
13	7.0248	50,000	3,51,240
14	6.6231	50,000	3,31,150
15	6.2593	50,000	3,12,965
16	5.9288	50,000	2,96,440

Since, the project cost is 3,00,000, it is found from the table above that IRR lies in between 15% and 16% differing by  $312965 - 296440 = 16525$  for 1% increase in interest rate. At the rate of 15% interest, the difference between the total Present Value (PV) of benefit and initial investment is  $312965 - 300000 = 12965$ . To compensate for this difference, an additional interest rate of  $12965/16525 = 0.78\%$  should be added with 15%. The IRR of the project is therefore 15.78%. Since 15.78% IRR is falling short of the prevailing interest rate of 20%, the project proposal is financially unviable.

Note:

- The project will be financially viable if the prevailing interest rate is equal to or less than 15.78%
- The project will also be financially viable if the annual return becomes proportionately higher than Rs.50,000 and/or the initial project cost is proportionately lower.

As such, benefit-cost ratio of a project depends upon its initial cost, productive life period and the prevailing interest rate. Other two factors remaining the same, it is the interest rate which affects the discounting factor. In such a case, higher the interest rate, lower will be the benefit-cost ratio and *vice versa*.

## **11.5 SOCIAL DESIRABILITY**

One of the guiding principles in all development projects is to allow a positive bias in favour of the disadvantaged groups. The approach followed is that the identified problems of the vulnerable groups should be addressed to the extent possible under priority considerations. Therefore, even if a proposal, may not apparently be satisfying the criteria for conventional financial viability, may still be considered for funding, particularly when issues like improvement of the status of environment, the women and the other vulnerable groups are involved. Various welfare and conservation projects like provision of drinking water and sanitation, afforestation in degraded lands, soil conservation measures, energy saving devices, rehabilitation of displaced persons, conservation of wild life habitat etc. receive a priority for funding by the donor agencies under the consideration of social desirability. The intangible benefits of these projects is believed to far outweigh the apparent tangible benefits.

Tangible benefits are those benefits which are the direct result of project implementation e.g increased availability of irrigation water, fuel wood supply etc. Intangible benefits are those benefits, which are derived indirectly due to the project implementation e.g creation of awareness and confidence, improvement of skills and managerial abilities, additional income generating opportunities, improvement in the quality of environment etc.

Although, the projects associated with higher social desirability need not necessarily satisfy the criteria for economic viability in quantitative terms but of course they must necessarily achieve the stated objectives of the project.

## **11.6 ENVIRONMENT IMPACT ASSESSMENT**

Environment is the sum total of all physical and biotic surroundings that affect the



life and behaviour of all living beings including man. The Environmental Impact Assessment (EIA) deals with evaluating the possible impacts, well in advance, of the major project interventions, both positive and negative to the common *biotic* and *abiotic* elements. Attention is focussed on both the direct and indirect effects, the project interventions are likely to bring about in the near future, to the natural resource base like land, water, forest, marine life, wild life etc. These concerns are further evaluated on their consequential effects on both human health and animal health including changes in wild life habitat. The common indicators used in WSD projects are to predict the possible changes in:

- Soil erosion and soil fertility.
- Grazing lands and animal health.
- Forest lands and availability of fuel, fodder, timber etc.
- Local bio diversity and crop yield.
- Use of chemical fertilizers and agro-chemicals.
- Status of groundwater.
- Quality of water and environmental sanitation.
- Outward migrations in search of employment.
- Conflicts and inequity in water rights and distribution.
- Wild life habitat and other ecological balances.
- Endemic diseases and associated loss of employment etc.

EIA is a study procedure to ensure that the development interventions under consideration are environmentally sound and sustainable. Any possible adverse environmental consequence are recognised early through *environmental screening* and corrective measures are taken into account in the project design by following *environmental scoping*. In short Environmental Impact Assessment is required to predict the likely impacts of the proposed project on environment, find ways to reduce undesirable impacts and to shape the project so that it suits the local environment and present these predictions and options to the decision makers.

Environmental degradation takes long time to set in and so does the corrective measures to show improvements. There are quite a few projects which have created a situation where “yesterday’s solution has become today’s problem”. In this context, it will be wise not to undertake implementation of a development

project at all, which is likely to cause large scale environmental degradation rather than applying the corrective measures later at a much higher cost. The scope of environmental screening particularly for large projects includes answering some of the following important questions :

- Can the project operate safely without danger of accident or long term health hazards.
- Can the local environment cope with the additional waste and pollution it will produce.
- Will the proposal create conflict in resource use e.g land use, water use etc. in nearby area.
- How will it affect local farm, fishery, industry.
- How much water, energy and other resources it will consume, is there adequate supply.
- What human resource it will require or replace and what social effect it will have on the community.
- What damage it may cause to the national assets e.g forests, tourism, historical and cultural sites.

Watershed management projects primarily aims at conservation, development and optimum utilisation of Natural Resources and hence are very much desirable from environment point of view. However, if not perceived properly, even these projects can generate adverse environmental effects e.g depletion of groundwater, quality deterioration of soil and water, loss of bio diversity due to monoculture etc.

## **11.7 ADDITIONAL REQUIREMENTS**

Notwithstanding the assessment of capabilities of the project proponent, one of the strategic tasks of the pre-funding project appraisal, is to assess if the proposed project period is sufficient to achieve the stated objectives. This is followed by identifying the infrastructure and man-power requirements for successful implementation. It may be necessary to make provisions for some of these requirements either directly or through establishment of linkages with other agencies. Linkages may be established for obtaining services from other related agencies through collaboration, consultation and paid services. Provisions are also

to be made to ensure that specialised services are available to the project proponent, as per need. If considered inadequate, building of the man-power and infrastructure requirements are to be considered so that the proponent can perform the task of project implementation successfully.

### **11.7.1 Uniqueness of Project Proposal**

It is the uniqueness or the unique selling point (USP) which makes a project proposal easily acceptable to most funding agencies. Projects that propose to adopt low cost community based solutions, apply a new methodology in community participation, develop an improved institutional model, promote and popularise a new low cost technology etc. normally find favourable response from most funding agencies for development projects. Use of well established development terminologies has become necessary to attract project funding as these assure the funding agency that the proponent knows its business.

It may, however, not be very easy, for a funding agency to distinguish between those proposals which are likely to be achieved from those which will hardly achieve much of what is proposed. Such experimental, high risk projects, therefore, require sufficient monitoring and process documentation for an unbiased appraisal from time to time during the project implementation to ascertain whether the project team is actually achieving, what it had proposed. Valuable lessons learnt at the end of the project period which otherwise should have been obvious in the beginning itself, is definitely not sufficient justification for funding of a project. To avoid losing focus, many funding agencies, in the recent years, have resorted to apply Result Based Management (RBM) practice after preparing a Logical Framework for the project components.

## **11.8 LOGICAL FRAMEWORK APPROACH**

Complex project proposals involving large funding are not decided based on one time appraisal. Once, a project proposal is accepted *prima facie* for funding, the funding agency may like to propose re-designing the format of the project proposal. This is done with the intend that the results, the project proposes to achieve, are made clear right at the beginning so that the project can be monitored adequately throughout its period of implementation and evaluated adequately as it

ends. This is usually accomplished by adopting a planning approach known as *Management by Objective* or the *Objective Oriented Project Planning*. Objective Oriented Project Planning is an organized method of project development and management using a Logical Framework (also known as Project Planning Matrix).

Logical Framework Approach (LFA) is an analytical tool for objective oriented project planning. The LFA, helps in bringing about high degree of clarity about the intents of a project. LFA also known as *Logframe* in short. It was initially developed for the U.S Agency for International Development (USAID) in 1970 as an evaluation tool to help increase its accountability. The method was further improvised by GtZ, the agency for German Technical Cooperation. The technique is now widely applied by most other International development agencies with minor variations. The final shape of a project proposal following LFA exercise is in the form of a *Project Planning Matrix* which presents the basic elements of the project at one place in a tabular form for better understanding at a glance.

### 11.8.1 Logical Sequence

In Logical Framework Approach (LFA), a project is broken into its basic elements namely the

- **Goal**
- **Purpose**
- **Outputs**
- **Activities**
- **Inputs**
- **Assumptions**
- **Indicators**

The key logical sequences on which LFA is based, are as follows:

- If the required **Inputs** are applied, then the desired **Activities** will take place.
- If the **Activities** take place, then the desired **Outputs** will be produced.
- If the **Outputs** are produced, then the desired **Purpose** of the project will be achieved.

- In the long run, this will contribute to the fulfilment of long term Development Objective or the **Goal**.

The logical sequence moves from each element to its next higher level, provided certain **Assumptions** (external factors) are fulfilled at each level. Assumptions are those external factors which are outside the direct control of the Project Team but have to be fulfilled for the development process to continue and the project to be successful. These uncertainties of the process are due the facts that when dealing with human behaviour, there are many such external factors. **Indicators** are a few selected parameters based on which the degree to which the project has been achieving its set targets, are ascertained.

The relationship between the project elements and successful implementation of a project is understood better by analysing the well known English Metaphor "One can lead a horse to water, but one can not make it drink". In this example,

- A thirsty horse is the **Problem**
- The water and the man are the **Inputs**
- Leading the horse to the water pool is the **Activity**
- The horse getting an access to drinking water is the **Output**
- A drinking horse is the **Purpose**
- A happy horse is the **Goal**

There are several factors which facilitate or prevent the horse from drinking the water. For example,

- The horse is genuinely thirsty i.e correct problem identification.
- The water is suitable for drinking according to horse's standard i.e the solution is acceptable.
- There is no predator present at the pool of which horses are naturally afraid of i.e availability of socially conducive atmosphere.
- The owner of the water allows horses to drink water from his pool i.e the ownership and accessibility of the resources allow the proposed development.

## 11.8.2 Project Elements

In order to design a project, the proposal is first broken down to its elemental form. Short descriptions of the project elements identified under Logframe are presented below together with a set of three typical examples. The first set of examples are from the projects adopting purely *technical solutions*, the second set follow an *empowerment approach* and the third set apply to typical bilateral projects.

### A. Goal

Goal is the "why" of the project. It is the ultimate reason for undertaking a project, so as to address certain development priorities of a region. As Goal is realised much later after the project is completed and also require contribution from many other similar projects, Goal is also referred as the *long term Objective*.

The stated Goal statement should be such that:

- It is the reason for undertaking the project.
- It is in line with the country's development policy.
- Target groups are clearly defined.
- It is not overtly ambitious.
- It is stated clearly and verifiably.
- It is expressed as an end and not as a process.
- Does not contain two or more objectives which are linked in a cause and effect relationship.

Examples of Goal statements:

- Reduction in poverty amongst the poor farmers in the region.
- Empowerment of the poor and disadvantaged communities in the area.
- Sustainable improvement of Natural Resources in the region.

Use of expressions which are not stated clearly and verifiably may however, be avoided such as “improved quality of life for the poor people”, “up-liftment of the rural poor” etc. While there is no harm in adopting such well meaning long term objectives, but the basic purpose of objective oriented project planning (OOPP) would be lost if the meaning of a particular phrase is not understood equally to everyone associated with the project.

There are several development terminologies, the meaning of which may be jointly shared by a large number development practitioners, but there is no harm in using words with more explicit meaning than implicit. If words with larger connotation must be used, it will be necessary to explain the dimensions or provide a clear definition of such terms e.g empowerment, sensitisation, sustainability etc. in the beginning of the project document

## **B. Purpose**

Purpose is the "What" of the project. It is the justification for the project. Purpose is also referred as *Immediate Objective* by some. A project should have only one higher level Purpose to make it more focussed. Experience demonstrates that multiple lower level Purposes (usually stated as Objectives) tend to weaken design and diffuse the efforts of implementation team. However, in case of complex projects like watershed management, there could be a listing of a few sub-Purposes for the sake of clarity (not agreed by many). Each of these sub-Purpose should necessarily be contributing independently to achieve the Purpose and may be related causatively i.e through an If-Then relationship with each other.

The project Purpose statements should satisfy the following criteria.

- Only one Purpose is stated (sub-Purposes which are linked by cause-effect relationship may be added for clarity.
- Target groups are defined precisely and verifiably.
- Achievement of the project Purpose will contribute substantially to the achievement of Goal.
- Likely to occur on production of Outputs.
- Stated as an end and not as a process.

- Out side the full and immediate control of the project team.

Examples of some common Purpose statements with added comments:

- Sustained improvement in income for the communities living within the watershed area (*n.b : target group is not very clearly defined*).
- Development of capacities and community institutions to manage the land and water in a more equitable, sustainable and gender sensitive way ( *n.b: will neither be easy to achieve during the project period nor likely to be verified objectively*).
- Improved capacity in the partner organization to promote Natural Resource management through community based institutions in the project area (*n.b: The project document must clearly define what is meant by community based institutions and how they are perceived to manage the natural resources*).

Purpose is the result which the project plans to deliver by the end of the project period. In order to improve the quality of a project, it is recommended that the project Purpose be kept slightly higher than that which can be achieved easily. But at the same time it should not be overtly ambitious and thus unachievable. A project with too ambitious a Purpose is a sure way of ending up with unfulfilled promises. It is more or less acceptable under LFA that while a project team must be able to generate all the planned Outputs, it should not be held responsible for the fulfillment of the Purpose specially when it is beyond the full and immediate control of the project team i.e designed under wrong Assumptions.

### **C. Outputs**

Outputs are the "How" of the project. They are results that must be achieved during the project period and sustained within the project life. Outputs are expected to lead to the achievement of the project Purpose. They are the results for which the project team is held directly accountable and for which it is given the resources. The characteristics of the Outputs are stated below:



- Outputs are the major results to be achieved through application and management of the Inputs through a series of Activities.
- State only those Outputs, achievements of which can be guaranteed.
- Defined precisely and verifiably.
- Defined as an end result and not as activities.

**Example: set 1**

- Private wastelands are brought under combination crops.
- Community wastelands are planted with trees.
- Reduced soil erosion from private farm lands and other wastelands.
- Increased storage and efficient use of surface water.
- Improved agronomical practices.
- Increased area under double crops.

**Example: set 2**

- Functional groups from identified caste/community are formed.
- Awareness and skills of the groups improved.
- Access to the credit facilities and other support services from Government programmes increased.
- Community endorsed village development plan developed.
- Target groups executed their own plan under supervision of the project team.
- The watershed committee took over charges of the community assets.
- Increased decision making role of the rural women in village development plans.

**Example: set 3**

- Work plan and a monitoring plan are prepared.
- Soil and water conservation measures are applied as planned.
- Increased area under afforestation and vegetative cover.
- Fuel wood saving practices are promoted and sustained.
- Improved agronomical practices demonstrated, promoted and sustained.

- Village level institutions, capacities and systems developed for management of the Natural resources.
- Increased capacity of the partner organization in delivering Natural Resource Management projects in a pro-poor and pro-women manner.

Outputs are found to occur at different levels. Achievement of a couple of lower level Outputs are necessary to finally achieve a higher level Output. There is no harm in defining Outputs at different levels. This, in some way helps in monitoring the progress of the project.

#### **D. Activities**

Activities are "What to do" of the project. These are the main actions that must be performed to implement the project. Each Activity is expressed as a process. All physical works, tasks, investigations carried out under the project are the project Activities. Routine administrative tasks are not included. Each Output should be the direct result of one or a set of Activities. Thus:

- Activities transform Inputs into Outputs.
- For each Output, only the essential activities are mentioned.
- Only those Activities are mentioned which will be performed by the project.
- Only those Activities are mentioned which contribute to the Outputs.
- Stated as actions and not as Outputs.
- Should be under control of the project.
- Should be the most efficient way to achieve specified Outputs.

Achievement of a single Output, will require undertaking a series of Activities. It is, however, important to list only those major activities which are important and crucial. Some examples of Activities corresponding to three typical Outputs, taken one each from each set of examples above, are presented below.

#### **Output # Increased storage and efficient use of surface water**

- Construct 2 check dams.
- Construct 3 surface water storage tanks.

- Construct field ponds. Construct 50 loose boulder checks in the streams/drainage lines.
- Contour trenches for run off harvesting.
- Construct earthen gully plugs in the cultivated lands.
- Promote 10 sets of community sprinkler scheme amongst 50 farmers.
- Construct 5 group lift irrigation schemes in x, y and z villages.

**Output # Community endorsed village development plan developed.**

- Arrange exposure visits for 30 farmers.
- Organize 5 training courses to improve skills of 75 farmers.
- Organize regular village planning meetings/ PRAs.
- Develop a draft village level development plan.
- Collect necessary data and conduct necessary surveys.
- Prepare design, layout, cost estimate for identified specific schemes (sub-Outputs).
- Prepare action plan, time planning, participation, contribution, utilization plan etc. for the scheme to be undertaken for implementation.

**Output # Increased area under afforestation and vegetative cover.**

- Create awareness about the significance of increased vegetative cover.
- Obtain written agreement from the Panchayat to ensure that the identified community land will be made available for plantation.
- Assess demands for species for the community and private lands.
- Promote nursery raising for desired plant species.
- Prepare land, construct cattle proof trench, pits, staggered trenches etc.
- Plant/distribute for planting the seedlings.
- Ensure protection and maintenance of the plantation area.
- Adopt an utilization practice for the produces.

Each of these Activities, will again require a series of sub-Activities to be performed. For example, the Activity “promote nursery raising for desired plant species” will require a minimum of the following sub-Activities.

- Discuss and identify groups for training in nursery raising.
- Provide class room training to all the identified group members.
- Identify, negotiate and take charges of the nursery raising plots.
- Develop reliable source of irrigation at each plot.
- Supply seeds or other propagative materials for the preferred species.
- Provide "on the job guidance" while raising nursery.
- Purchase the seedlings back at a remunerative price.

## **E. Inputs**

Inputs are the resources necessary to initiate the Activities that are likely to produce the proposed Outputs. Inputs are fund, personnel, equipments, reports, services, time etc. provided under the project. A great deal of Inputs also come in the form of organizational, intellectual, human and physical resources contributed directly or indirectly by the stakeholder themselves. Inputs should be identified in such a way so that they

- Could be related to a specific activity (budgeting).
- Should be sufficient to realize the activity within the given time frame.

## **F. Assumptions**

Assumptions are the "Only if" of the project. These are the conditions necessary for the success of the project but are not under the complete control of the project management. The uncertainties associated in transforming the results from its lower level of happening to the next higher level are defined by the Assumptions for that particular level. Therefore, fulfillment of all the Outputs plus the Assumptions generate the Purpose and similarly, fulfillment of Purpose plus Assumptions lead to the Goal.

If the Assumption is very obvious and is sure to happen then there is no need to consider the same. Only those Assumptions should be considered which are necessary for the project to be successful but are associated with certain amount of uncertainties. Assumptions are to be monitored regularly to check if it is being satisfied and if necessary, attempts should be made to make them happen. If an

Assumption is highly unlikely to happen but is absolutely necessary for the project's success, then it is considered a *killer assumption*. Such Assumption jeopardize the chances of project success right from the beginning. The project proposal in such a situation should either be abandoned or must be redesigned. Certain Assumptions are not likely to happen under normal circumstances due to associated administrative procedures or the bureaucracy. Such Assumptions may be removed simply by turning them in to pre-conditions for project for funding. Assumptions should be such that they are:

- Stated as a positive condition.
- Related to a specific level in the project planning matrix.
- Defined precisely and verifiably.

Some typical examples of Assumptions in relation to watershed development projects are presented below.

- The rainfall and other climatic conditions in the project area remains normal throughout the project period.
- The assistance from the on-going Governmental programmes/Financial institutes will be forthcoming as promised/expected.
- The demand on the natural resources and the consumption pattern within the project area will remain more or less the same throughout the project period.
- The political environment remains sympathetic to the project approach and its objectives.
- The caste and class conflict within the project area remains manageable throughout the project period.
- Village communities does not get confused due to the misinformation campaign initiated by the vested interests and remain committed to the tasks/responsibilities they intended to perform/share.
- The new technology being adopted will yield the desired result.

The aspects of efficiency, capacity, motivation, effectiveness etc. of the project team are not included as the Assumptions since these are well within the control of the project management. Similarly, timely receipt of fund need not be included unless it is really an important issue.

The simplest way of identifying assumptions is to ask the question if the stated condition is absolutely necessary for the success of the project. If the answer is *Yes* then the next question will be is it under the control of the project management. If the answer is *No*, then the condition should be included as an Assumption.

## **G. Indicators**

Indicators are the criteria based on which the results (Outputs and Purpose) of a project are evaluated. These are the signals for successful accomplishment of each level of objectives in the project plan. Indicators reflect the essential aspects of an objective in precise term and is independent at different levels. These should be factual and the changes observed can be directly attributed to the project interventions. Indicators should be such that they

- Specify results in terms of target groups, quality, quantity, time and location.
- Focus on important aspects of the achievements.
- Measure change at a specified level.
- Must be valid in time scale.
- Must be reliable and precise.
- Must be cost effective

A good Indicator should be **SMART** i.e

- **S**pecific
- **M**easurable
- **A**chievable
- **R**elevant
- **T**ime bound

The ideal Indicators, particularly those which are used for monitoring a project should also specify the target groups (for whom), quantity (how much), quality (how well), time (by when) and location (where).

A number of physical parameters could be used as an Indicator of change. Some

common parameters are:

### **A. Soil erosion**

- Soil fertility, particularly the organic matter.
- Soil thickness as measured by installing stick gauges at strategic locations.
- Turbidity of run off water leaving farm lands.
- Rate of filling of silt traps constructed specially for monitoring soil movement.
- Rill formations before and after treatment of identified plots.
- Comparison of both treated and untreated gully heads.
- Direction of shift in agronomical practice, crop preferences, land use.
- Actual stream gauging and silt monitoring at selected locations

### **B. Water Conservation**

- Number of water storage structures constructed, their storage volume, direct withdrawal from storage and other losses.
- Stream flow at the outlet, run off peaks, floods, silt load at the outlet.
- Period of base flow in seasonal streams.
- Seasonal water levels and pumping hours (yield), when the number of existing wells and water application methods remained unchanged.
- Extent of area irrigated under the same crop before and after installation of improved water application technology e.g drip, sprinkler, pipes.
- Depth and frequency in application of irrigation water due to change in soil moisture status.
- Change in crop diversity attributable directly to water quality.

### **C. Afforestation**

- Percentage of survival
- Type of land e.g Land Capability Class, Ownership (common or private)
- The type of species planted and their intended use
- Number of seedlings used for plantation raised in local nursery
- Produces from the plants, grass and their use (fuel, fodder, timber)

- Direct evidence of the plantations on environment (soil, water, energy) and ecology (habitat for wild life).

#### **D. Socio-Economic impact**

- Crop diversity, crop intensity and crop yield
- Employment pattern, diversification of occupations
- Collection time of fuel wood, drinking water and in drudgery
- Income, savings, debt, control over market etc.
- Off-farm, environment friendly income generating activities

Assessment of these changes are, however, done separately as a part of post implementation evaluation. Unless, the project design provides for sufficient base line data, these impact assessments would remain more subjective in nature. Sometimes, It may be useful to carry out separate studies to document the lessons learnt and make future recommendations.

Examples of Indicators:

- At least 50 ha of community lands brought under plantation every year throughout the project period.
- At least 50 ha of lands brought under double crop every year throughout the project period.
- By the end of the project period, at least 20% savings in fuel wood consumption took place due to introduction of the energy saving devices.
- By the end of the project period at least 80% of farmers achieved a minimum of 25% increase in income out of which at least 50% are small and marginal farmers.
- By the end of the project period, 80% village institutions are able to meet at least 50% of the functional criteria set for them (These criteria are to be listed separately), out of which at least 10% village institutions meet more than 80% of these criteria.



## **H. Means of Verification**

Means of Verification (MoV) are the basis on which the Indicators are evaluated and substantiated as far as possible. Common means of verifications include project records, interviews of project staff and the beneficiaries, data collected by the project and other agencies, field survey and appraisal. The MoV should be such that they

- State the type of data to be collected.
- State the sources of information to be consulted.
- Exist outside the project activities.
- Should provide valid, reliable and accessible data.
- Are not stated as inputs.

Means of verifications include:

- Counting, measuring etc. of the physical parameters in the field.
- Perusal of the records maintained for the purpose.
- Conducting special survey for the purpose.
- Discussions with the communities.

The purpose of using Indicators, is to measure and monitor the progress of the project. The criteria for selection of Indicators, therefore has been made very specific so that the Indicators remain objective in nature preventing any undue claim of achievements by the project team. In reality, there are very few Indicators which need little efforts and at the same time measure the changes objectively. Quantitative Indicators are easy to use but these need collection of data which may be time consuming and expensive. Qualitative Indicators are relatively easy to apply but may not be as objective as required for serving its purpose. It will, therefore, be advantageous for both project planning and monitoring to prepare a pre-project data base on some basic parameters of the project area and monitor the same through out the project period as an integral part of the project implementation. The role of actual field appraisal by outside monitoring and evaluation missions, therefore, remains as important as ever. Such missions, however, must operate under a constructive attitude giving only practical and

achievable recommendations than sitting over judgment and listing out only the shortfalls.

## **11.9 PROJECT PLANNING MATRIX**

The central task in project designing using Logframe is to prepare a Logframe or a Project Planning Matrix (PPM) which is a tabular presentation of the project proposal relating the Goal, Purpose, Outputs, Activities, Inputs and Assumptions in the background of the adopted project approach and strategy. It, therefore, helps in understanding the project intents at a glance.

A Project Planning Matrix is arrived at gradually by systematically analyzing the problems and their solutions in the background of the approach and the strategy to be adopted for the project. A project strategy is normally developed by seeking answers to the questions like What, For Whom, By Whom, How and When of the project. Identification and analysis of the core problem lead to the formulation of a problem tree. A problem tree is then converted into an Objective tree simply by converting the negative statements with the positive statements. This in turn lead to the development of project Purpose and project Goal. The entire process of analysis is normally done through a group activity known as LFA workshop.

## **11.10 LFA WORKSHOP**

Development of a project planning matrix through the application of Logical Framework Analysis (LFA ) is normally achieved in a LFA workshop. A resource person familiar with the LFA technique is selected as the moderator who facilitates the proceedings. A small working committee is also nominated for the purpose of consolidating the discussions at the end of each day. It is desirable that the workshop be conducted in the project area itself by people representing all groups associated with the project (stake holders) e.g from the funding agency, the implementing agency, the technical assistance team, local institutions, village representatives etc. It should be stressed to the group that all participating members has equal status and rights in providing suggestions without hesitations. The role of the moderator is most crucial. He would guide in the development of the project design yet without asserting any direct intervention. The members are first given a background of the LFA, outlining the flow of logic to be developed. Background

reading material may be provided well in advance, if necessary.

The process begins with identification of the focal problem(s) and development of the Problem tree. Analysis of the Problem(s) lead to framing of the Purpose and Goal statements of the project. A Problems tree is then converted into an Objective tree. A list of Outputs which shall lead to the fulfillment of purpose are then stated. These Outputs decide what should be the necessary Activities and Inputs for the project. After the project framework is sufficiently developed, the Assumptions and Indicators are to be laid down.

### **11.10.1 Development of Problem Tree**

Visualization techniques using cards and chart papers have been found to be quite effective in conducting LFA workshops. Each member is asked to identify the problems of the area with respect to the project intents and the adopted strategy. One problem is written down in one card only. Problems should be stated not as an absence of a solution but as an existing negative state e.g " Wells need depending" will be wrong problem statement, correct one will be "groundwater level has gone down." All problem statements identifying the more or less the same problem but written in a different manner are discussed and rewritten to club them into a single problem statement.

The next step will be to select a starting point i.e identifying the focal problem. This is done by studying all the problem statements and sorting them out in a order of hierarchy. The hierarchy of problem placement be such that each lower and higher level problems are linked in a cause and effect relationship. This finally leads to the preparation of the problem tree. A Problem tree is developed by placing the focal problem in the top and placing the smaller problems down below in branches containing a set of smaller problems. A typical problem tree is presented below.

The problem tree thus developed is reviewed to verify its compactness and validity. Problem statements may be modified, clubbed or split as per consensus.

In order to be effective in developing a problem Tree, the Team members are advised to keep the following in mind.

- Be positive in attitude.
- Write only one statement in one card.
- Statements should be simple, clear in their implications avoiding ambiguity.

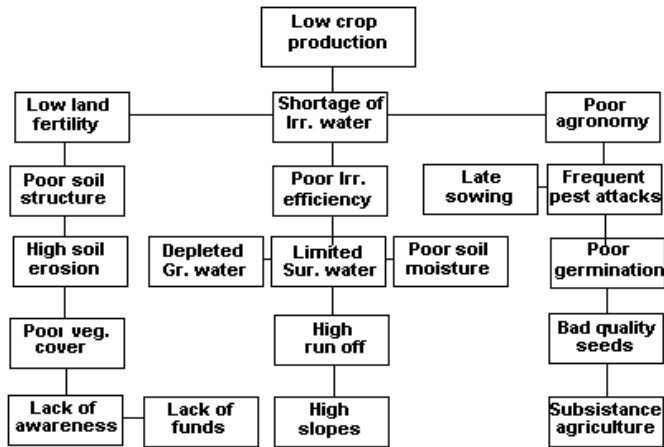

Fig. 9.1 Example of a typical problem tree

- Cards are placed one below the other by the moderator.
- Cards having similar statements are placed next to each other and a common single statement is developed through consensus.
- Moderator should refrain from getting involved in discussions and restrict his/her role only to the LFA methodology.
- Position of the statement could be moved up, down or side wise temporarily by the moderator and finalized late after consensus.
- If discussions become lengthy or unproductive they should be discontinued temporarily till more information are gathered.
- Lines indicating causal relationship should be done only at the end of the session to obtain the final problem tree.

The problem tree is then transformed into an objective tree by converting the problems in each card with a positive statement that describes the absence (solution) of the problem. The cause-effect relationship is converted to the means-end relationship. A typical objective tree is presented below.

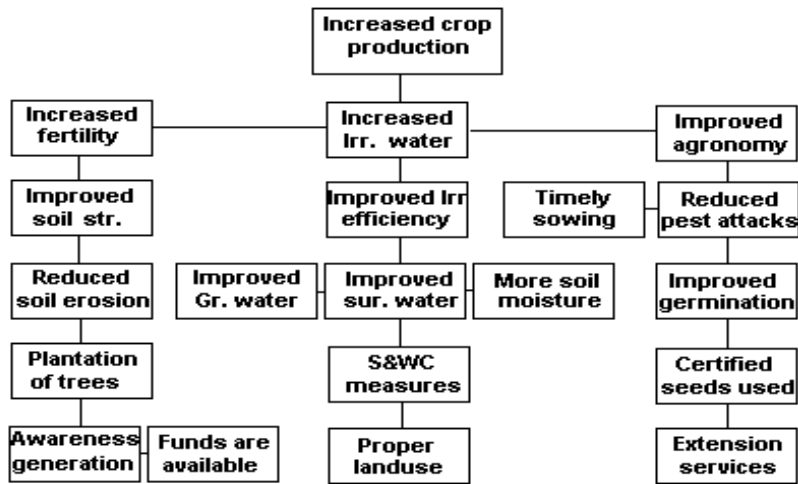

Fig. 9.2 Example of a typical objective tree

### 11.10.2 Development of Project Planning Matrix (PPM)

Arriving at a Project Planning Matrix is one of the important end-product of a LFA workshop. Once the Goal and Purpose of the project are set and accepted by all the stake holders, the Output statements are developed. Output statements are obtained by transforming the major problems into future solutions. Outputs should not be visualised as just the end of an Activity or a set of Activities but more as the consequence or the result of these Activities.

All the Outputs necessary to achieve the project purpose must be listed. Smaller problem statements lead to arriving at necessary Activities for the project. A consolidated Project Planning Matrix is finally developed drawing liberally from the various Output, Activity and Assumption statements generated in the LFA workshop. After having stated the Outputs, attention is focused on the Assumptions. Assumptions at the Output level should be such that if the Outputs are generated and the Assumptions are fulfilled then logically the project Purpose should be achieved.

In a LFA workshop, where the participants are not very familiar with the technique, it may be useful, if the workshop moderator keeps a number of statements prepared well in advance. These statements are placed as options for

each project elements and the participants chose the ones they consider most appropriate. The final statement however, must be arrived at through consensus in the LFA workshop. The final outcome of a LFA is the preparation of a project planning matrix.

The standard structural format for a Project Planning Matrix following LFA is presented in Table 11.1.

<p><b>1. Goal (Long term objective)</b> The highest level of objective towards which the project is expected to contribute. (Mention target group)</p>	<p><b>1. Indicators</b> Measures directly or indirectly to verify to what extent the Development Objective is fulfilled. (Means of Verification should be specified)</p>	<p><b>1. Assumptions</b> Important events, conditions or decisions for sustaining the Goal in the very long run.</p>
<p><b>2. Purpose (Immediate objective)</b> The effect which is expected to be achieved as the result of the project. (Mention target groups)</p>	<p><b>2. Indicators</b> Measures directly or indirectly to verify to what extent the Immediate Objective is fulfilled. (Means of Verification should be specified)</p>	<p><b>2. Assumptions</b> Important events, conditions or decisions outside the control of the project which must be fulfilled for achieving the Goal.</p>
<p><b>3. Outputs</b> The results that the project management should be able to generate. (Mention target groups)</p>	<p><b>3. Indicators</b> Measures directly or indirectly which verify to what extent the Outputs are produced. (Means of Verification should be specified)</p>	<p><b>3. Assumptions</b> Important events, conditions or decisions, outside the control of the project management necessary for the achievements of the Purpose.</p>
<p><b>4. Activities</b> The activities that have to be undertaken by the Project in order to produce the Outputs.</p>	<p><b>5. Inputs</b> Goods and services necessary to undertake the activities.</p>	<p><b>4. Assumptions</b> Important events, conditions, decisions, outside the control of the Project management necessary for the production of the Outputs.</p>

**Table 11.1 Standard layout of a project planning matrix (logframe)**

### **11.10.3 Check list for a Project Planning Matrix**

After having arrived at a project planning matrix which is also referred commonly as the Logframe, it may not be a bad idea just to double check if the PPM (Logframe) is in order. The following check list is useful to this end.

- The project has one Purpose
- The Purpose is not a reformulation of the Outputs but something more
- The Purpose is outside the management responsibility of the project team
- All the Outputs are necessary for accomplishing the Purpose
- The Outputs and the Purpose are stated as results not as a process
- The Activities define the action strategy for accomplishing each output
- The relationship between the inputs and Activities is realistic
- The Outputs plus Assumptions at that level produce the necessary and sufficient conditions for achieving the Purpose
- The Indicators at the Purpose level are Independent from the Outputs. They are not a summary of Outputs but measure of the Purpose
- The vertical logic amongst Activities, Outputs, Purpose and Goal is realistic as a whole.

### **11.11 LOGFRAME AND PROJECT MANAGEMENT**

Although use of LFA began in USA as early as 1970, its use remained limited. It was only in the late 1980 when a number of multilateral agencies, in their search for establishing accountability took Logframe seriously and trained a large number of their staff in this method. The approach was standardized finally as Result Based Management (RBM) by Canadian International Development Agency (CIDA). In RBM, the Results are categories at three levels namely Output, Outcome and Impact which correspond to the Output, Purpose and Goal of the project respectively. Under this management approach Results of the project are defined first and only then the Activities to achieve these Results are undertaken i.e the entire emphasis shifts from Activity oriented project management to Result oriented project management. Now a days, RBM-Logframe is applied by almost all

development agencies to most of their projects small or big.

### **11.11.1 Advantages**

- The Project Planning Matrix (PPM) developed in a LFA helps in systematic analysis of all project components and narrows down the project to its basic elements cutting through the Jargons.
- LFA workshop attended by the representatives of all the stake holders and conducted by an independent moderator not only enhances the planning and analysis of the project elements bringing them into a sharper focus but also helps arriving at consensus with regards to the development approach amongst a widely divergent groups.
- It enhances communications amongst the members of the project team and others related with the project bringing them to a common level of understanding about the project intents as a whole thus reducing the scope of the project staff working at cross purposes.
- Since LFA facilitates laying down the Output statements in unambiguous and achievable terms, it is found very useful for monitoring and evaluation of the projects. It provides basis for systematic analysis of the impacts (evaluation) of the project and can locate easily the areas of shortcomings at both the implementation and post-implementation stages.
- It helps in standardizing the procedures for management and administrative practices within a project and hence the project may not suffer from discontinuity when the original project staff are replaced.

### **11.11.2 Limitations**

- LFA is an analytical tool and hence is as good as the mental make up of its users. It begins with problem analysis and it is assumed that the problems are already known. The problem analysis sometimes gets influenced by the mental make up of the participants attending the LFA workshop.
- In reality, the LFA workshops seldom include the views and aspirations of the actual target groups in formulating the Goal and Purpose statements. The framework for Goal and Purpose usually remains pre-decided in almost all funding mechanisms. It is the task of the project implementing agency to



make the target groups accept these objectives and derive as much benefits as possible within this given framework.

- It makes project planning appear simple and the result statements innocuous. It does not in anyway facilitate in actual implementation i.e transferring the Activities into Outputs. There is always a danger of designing over ambitious and rather unachievable projects without actually realizing the same.
- In its structural form, Logframe is applied to all types of projects, be it sectoral, compartmental, national, grass roots level, commercial, institutional, environmental etc. The logical sequences followed do not have any scope for making provision for the element of time involved in actually moving from one lower level result to the next higher level. For example, while a machine installed is expected to start production almost immediately, but a seedling planted today will take 20 years to produce the timber.
- The most potential area of weakness in LFA contributing to the causes of project failure lies in accepting an impossible Assumption. In fact, during project implementation, a great deal efforts may be lost in monitoring and managing and in trying to make a bad Assumption to actually happen. Although recommended but reformulation of a project is seldom done because of the presence of an impossible Assumption.
- LFA is recommended as a complete package for project formulation, implementation, monitoring and evaluation. It, however, does not replace the need for several other Activities in project formulation and management e.g micro planning with the target groups, establishment of linkages with other agencies, utilization of the created assets, conflict resolutions etc.
- It is too logical in its design and does not readily provide much room for qualitative assessment while evaluating a development project. Additional efforts are necessary to capture the qualitative aspects of a development project and its intangible benefits.
- There are groups who believe that LFA, once adopted must be followed strictly as recommended including framing the statements as per the suggested syntax. There are others who take LFA as just a planning methodology and in their eagerness to infuse flexibility use statements in any form and syntax. This creates confusion at least amongst the planning

groups, resulting in each one believing that the other does not understand the dynamics of the project.

- The Project Planning Matrix is the basis for evaluation of a project. It is an effective tool in bringing out objectively how much a project team has failed in achieving the results against what was planned. This tool in the hands of those who never had to implement any project, has a potential for unfairly undermining the efforts of the project manager and the entire project team.

## **11.12 PROJECT LAUNCHING**

Once the project implementation team is in place and the project planning matrix has been developed, the project is ready for launching. The project planning matrix, particularly the Purpose statement forms the basis for developing the project implementation plan including the work plan and the monitoring plan. In the course of implementation, if the project planning matrix is found to be too ambitious or not capable of addressing the aspirations of the target groups, it is possible to make the necessary amendments. Such changes, however, must be made in another LFA workshop attended largely by the target groups and with due consultation and consent of the funding agency.

## ***12.0 Project Implementation***

---

### **12.1 PROJECT TEAM**

Organizing a potentially effective project implementing team, no doubt, is one of the most crucial tasks. To begin with, at least, a small functional team should be raised as soon as the project approval document is signed. The process of identifying potential team members, therefore, may be initiated simultaneously as the project proposal was being negotiated with the funding agency. Success of a project depends as much on its design as on an motivated project team. If the project objectives are ambiguous or over ambitious and without adequate Inputs, it is obvious that no project team will be able to generate the expected Results. But, conversely, it is true that even a badly designed project may still be executed in a meaningful way by the project manager and a balanced project team.

The process of selecting the team begins by analysing the job requirements, further fine tuned by the priorities of the funding agency, nature of the project and socio-cultural background of the project area. An ideal project manager should have past experiences in executing similar project(s). S(he) should preferably have, a number of qualities such as a clear understanding of the project objectives, ability to develop and sustain team spirit, an innovative mind-set, proficiency in public relation and capacity in balancing between the claims of conflicting interests etc.

Obviously, there will be no such person as a perfect project manager. One single person cannot possess all these qualities in equal abundance and still remains a project manager for long. Each project manager may be expected to be strong only in some of the above endowments with adequate common sense. While a *taskmaster* type of project manager can achieve physical results faster which is rather useful for short term gains, an imaginative manager may generate physical progress rather slowly which are likely to be more sustainable in the long run. Appointing different project managers of different calibre at different stages of project execution could, therefore, be a well accepted project management strategy.

The rest of the project team needs to be sufficiently balanced and should be able to function as one unit. The balancing need not only be in terms subject matter specialities but also in terms of their attitudes, experiences, motivations and capacities to work together in a multi-disciplinary environment. The role of the deputy project manager i.e. the second in command is also quite relevant in enhancing or diminishing the performance of a team. This is all the more so when the project manager is not capable of providing sufficient leadership.

The project area must be easily accessible to the project team. For this reason, the project office should be situated within the project area or as close to the project area as possible. In case, the main project office has to be located at a far away location for other administrative considerations, it is imperative that a self-functional field office is opened within or near the project area.

## **12.2 PROJECT MANAGEMENT PLAN**

If the project funding has been made on the basis of a skeletal plan then a detail *Project Management Plan* (PMP) needs to be prepared before embarking upon full-fledged implementation of the project. The Project Management Plan lays down the relevant management practices to be adopted for implementation e.g approach, strategy, funding, phasing, monitoring, evaluation etc. The PMP is the final project document outlining what the project plans to achieve and how and when these would be done. This document not only helps in laying down the project intents in the beginning but also serves as guidelines to be referred throughout the project period for the purpose of monitoring and evaluation.

### **12.2.1 Work Plan**

For the sake of actual execution, however, it will be necessary to prepare a separate project level plan normally referred to as a *Work Plan* or an *Action Plan*. A broad work plan normally lays down a listing of the major Activities and allocate a time frame with a budget provision for the same. Preparation of a broad work plan not only requires sufficient conceptual clarity within the project team developed after considering a wide range of parameters such as project priorities, anticipated flow of budget, man power and expectation of the local communities. Preparation of a work plan, therefore, is not an one-time activity. The original work plan most often

requires periodical review so as to bring about necessary changes as the implementation continues. The broad work plan is normally broken down into quarterly or half-yearly work plans for proper management.

### 12.2.2 Micro Plan

In order to fine tune the work plan, attempts are made to incorporate as much feed backs from the target groups as possible through a process often referred to as *Micro Planning Exercise*. Ideally, the scope of micro planning includes:

- sharing with the communities the project intents;
- formation of user groups and nomination of their leaders;
- finalization of project activities for each group;
- working out location, cost, design etc. of major physical structures;
- working out extent of contributions and mode of realisation of the same;
- working out the time line for major activities i.e what will be done when and where;
- delegation of roles and responsibilities to members of each group;
- laying down foundation for the formation of village level management committee.

Quite often, micro planning exercises are undertaken by project executing teams more for legitimising their work plan than considering this as a means for mobilising community participation. It is obvious that the role of micro planning exercise is much more than just preparation of the work plan. While the work plan may be an annual exercise, the micro planning is the very basic process which lays down the foundation for institution building thus need to be carried out periodically throughout the project period.

### 12.2.3 Time Line

Conventionally, a work plan is prepared in the form of a *Time Line*. A work plan is developed first by considering the Outputs the project plans to produce within a given time frame. The Activities required to generate these Outputs are then identified. The major Activities are broken down further into a series of sub-

Activities and time limits are allocated for achieving the same. There could be separate time lines for the quarterly planning, half-yearly planning, annual planning etc. The time planning should be as realistic as possible. Since no time is considered sufficient for proper implementation of a project, a sufficiently loose time line offer several advantages. A loose time line can be worked out by considering only the major or the milestone Activities. This provides the project team an opportunity to cope with various unforeseen situations which eventually turns up in the process of execution.

At times, a tight time line may be adopted as a deliberate strategy. Whenever, a tight time line is proposed, the project team will remain almost always behind the proposed time schedule. This in turn force the project team to work under constant pressure thus giving more Outputs. Such a strategy may be acceptable in a construction type of project but needs to be applied with sufficient restraint in development projects so as to maintain the qualitative aspects of the project.

### **12.3 ENTRY PROGRAMMES**

When a project implementation begins primarily with large scale data collection in a new project area, many local persons may view the activities suspiciously. For this reason, it is suggested that an external agency may begin with the task of *establishment of rapport*. Rapport building requires gaining confidence of the target groups. This is normally achieved by undertaking initially some simple but high priority development activities endorsed by a majority of the communities. Such activities are commonly referred to as *entry programmes*. The opportunities for entry programme are many which may include augmentation of drinking water supply, excavation of the existing community tanks, repairing of roads, bunds, community buildings, formation of savings and credit groups and the like.

Credibility can also be established by providing linkages to bring into the project area the benefits of the on-going development programmes of the state Government being delivered in the neighbouring area. One very useful entry programme has been found to be the establishment of women's savings and credit groups known popularly as Self Help Groups (SHGs). Establishment of grain banks, seed bank, fodder banks etc. have also been found to be useful entry programme activities in poverty and drought ridden tribal villages. Many funding

agencies, however, are not willing to support those entry programmes which do not form an integral part of the main project.

The period for *entry programme* or the *preparatory phase* also offers the opportunity to understand the power structures, caste hierarchy, community attitudes and other social dynamics prevailing in the village. Individuals and groups may be identified during this period under different categories such as natural leaders, opinion makers, trouble makers, exploiters, vulnerable groups and the like. Project formulation could accordingly focus its strategy more in favour of the vulnerable groups. This is also the period when the people watch the external implementing agency very critically to form their opinions. It is, therefore, important that the implementing agency remains frank and honest at this stage. The external agency should avoid making promises that cannot be fulfilled later.

#### **12.4 COMMUNITY PARTICIPATION**

The term *people's participation* is very general in nature, considering the fact that all adults, living within and outside the watershed are *People*. A section or a group of these people referred in a particular context of class, caste, occupation, economic status, interest, habitation (hamlet) etc. are communities. Thus a wide ranging communities can be identified in the context of watershed management e.g user group, caste group, occupational group, women's group, vulnerable group and the like. Though, used inter-changeably, the term *community participation* has more specific connotation in the context of project implementation than the term *People's participation*.

Participation, in its simplest sense means "to take part in an activity with other people". But in its larger perspective, community participation is often viewed as an evolutionary process wherein the beneficiary groups take active part in their own development which in turn empowers them. Empowerment is viewed as a situation where the community in question becomes capable of making their own decisions as a group through a democratic process and actualise these decisions under a self-help attitude. Capacity building is considered the key ingredient for empowerment. It is widely believed that the capacity of the communities can be enhanced by involving them in the process of the planning and implementation of the project.

Community participation in the context of natural resource management may be viewed as a process where the associated communities are motivated to contribute as a group to perform a series of identified tasks for the conservation, utilisation and management of their land, water, bio mass and other related resources to derive the benefits in a rational manner. In real terms, this would mean that the communities have been rendered capable enough to increase productivity of the privately owned resources individually and manage the community resources jointly.

#### **12.4.1 Change in Approach**

In the earlier years of post independent India, the soil and water conservation interventions in the country concentrated primarily on applying treatment measures in the catchment areas adopting purely a technically suitable approach. Consequently, people became indifferent to these activities failing to see any direct or indirect benefit that may accrue to them. In the 1980's, the focus shifted towards integrated watershed approach. In an effort to sustain the project benefits, the Central agencies advocated the need for people's participation. The NGO projects in the mean time placed community participation in the central stage. Processes like need assessment, group discussions and involving the communities in implementation became important project activities. The practice of collecting a nominal contribution from the beneficiaries became a standard norm. The concept was further advanced including training of various functional groups so that the communities themselves could take care of the operation and utilization of the assets created under the project.

Participatory planning process like Participatory Rural Appraisal (PRA) and micro-planning exercises are necessary for mobilizing community participation. Extensive exposure visits and training imparted to local leaders are expected to enhance their capacity. Community participation is considered necessary not only for a sustainable project implementation but also for building their capacity. Capacity building is considered important with the view that this will make the communities capable enough to solve their own problems in the future by themselves. This will of course require a great deal of reorientation in our approach to design the future projects. Also, the Project Implementing Agencies would



require to have attitudinal change so as to allow the relevant decision making powers actually transferred to the beneficiary communities.

#### **12.4.2 Participatory Development**

Some criticize, perhaps rightly that in the conventional approach of mobilizing community participation, the implementing agency according to their own priorities first design the project intended to benefit the communities. Community participation is sought, if at all, at a later stage merely to internalize the plans so as to achieve the targets. As opposed to this, the ideal situation should be such that the communities by their own participation, set their own goals and achieve them as per their priorities, drawing support from all possible sources willing to help. While the former is known as participation in development or the *Top down approach*, the latter is referred to as participatory development or *Bottom up approach*.

Most of the organised development initiatives are necessarily funded by external funding agencies with well defined project Objectives. The Project Implementing Agency (PIA), in turn, makes an attempt to produce these results within a given budget and time frame. Although, these development results are expected to be achieved through intense community participation, but neither sufficient provision for time nor any deviations from the stated results are permitted. Moreover, the implementing agency may also be reluctant to transfer a substantial part of decision making power to the communities for the fear that the expected results may not be generated in time and the project may finally deviate substantially from the stated objectives. In its true sense, unless drastic changes are brought about in the procedure for project design, funding and monitoring, not many donor driven development projects could be truly bottom up in character. The best compromise perhaps will be if a top down and bottom up approach can somehow meet in the middle to generate a satisfactory level of results.

Keeping the above views in mind, it appears that a realistic blend between these two approaches is still valid which may be worth pursuing as the first step towards participatory development. This, however, calls for some important changes in the attitudes of both the funding and the implementing agencies. The implementing agency under this approach would be required to first set the broad objectives or

the purpose of the project. A development process is then allowed to be built up by involving the communities in the planning process remaining sensitive to the community needs, opinions and priorities.

In other words the project team would be required to transfer or share some of the decision making powers with the communities for whose benefit the project is planned in the first place. The funding agency, in its part, may not only support this approach by allowing an inception phase but also support funding of community driven projects. The communities in their part need to be more proactive remaining willing to get involved in some of the project activities particularly those which affect their lives directly.

### **12.4.3 Degree of Participation**

Mobilizing community participation, capacity building and development of community institutions etc. are on-going process thereby it may be difficult to conclude when sufficient capacity building have taken place. Watershed development projects on the other hand deals primarily with the management of land, water, vegetation, livestock and the rest, with the objective of improving their productivity by the end of the project period. The role of community participation in watershed management projects, therefore, can not be viewed as an open ended process particularly for an agency implementing a large number of projects. Community participation to such agencies remain a *means* rather than an *end* by itself unlike to those adopting Institutional approach.

To begin with, therefore, even mobilizing partial participation or seeking community cooperation would be useful as long as this helps in generating stable benefits for larger communities than projects implemented without any participation at all. After all, full participation must necessarily begin with part participation. The process of participation essentially begins with seeking community cooperation with the intend of strengthening their capacities. Sometimes, participation of the local communities are sought for a limited purpose which could be consultative, contractual or co-opting in nature. This type of relationship is normally sought more for the sake of achieving the targets than any serious concern for capacity building. The purpose and the extent to which the community participation will be sought in a project should, therefore, be defined

clearly right from the beginning accepting the limitations with pragmatism. This is much better than promising a very advanced model of community participation with no idea about how to actually achieve the same.

#### **12.4.4 Mobilizing Community Participation**

The real problem encountered by the field staff, however, is how to initiate this process of community participation and sustain their interest throughout the project period. The critical prerequisite for sustaining community interest is to let the communities develop a sense of ownership to the project. In a participatory approach, therefore, the project implementing staff should be able to allow the communities to feel that the project belongs to them by allowing the decision making process at the community level. Community decisions are normally arrived at through focussed group discussions or PRAs in which the communities undertake a systematic appraisal of the resources they have, analyse the existing problems and opportunities to identify the course of actions to be taken.

The next step could be the formation of a project implementation committee from amongst the communities to plan and undertake project implementation. For larger watersheds, there should be a number of implementing groups and a project management committee (watershed committee) to provide overall guidance and supervision. The village Implementation groups/committee should then be allowed to implement different aspects of the project as per the existing capacities within the communities. The major steps recommended for involving the communities in a watershed management project may, therefore, broadly be outlined as:

- Conduct a Participatory Rural Appraisal (PRA) in the village to understand the problems and the solutions as perceived by the communities with respect to the management of their natural resources.
- The PRA, amongst other, must help the communities in bringing out a current resource utilization map for the entire village and a skeletal plan for both immediate and long term needs.
- Conduct several planning workshops with the communities using extensive moderation technique to establish immediate and long term objectives i.e the Goal and Purpose statements. This will eventually lead in identifying the

Outputs that would be generated for achieving the project Purpose.

- If the project already has a project planning matrix prepared at the formulation stage for the purpose of project funding, improvise the same by incorporating the aspirations of the communities and get the final proposal approved by the funding agency. Form a committee from amongst the identified villagers which will undertake the responsibility of implementation of the final plan that has been developed on consensus.
- Allow the implementation committee to prepare a broad work plan and review the same for improvements.
- Arrange training for capacity building of the key persons.
- Allow the community to implement as per their capability.
- Provide technical assistance as per need.
- Provide funds as per progress.
- Introduce a monitoring mechanism (usually village meetings) so as to keep track of the extent to which the proposed Outputs are being achieved. Introduce corrective measures to be arrived at through group discussions.

In the entire efforts cited above, the project team and the village implementation team will be required to work together as one where the project team will consciously play the role of a facilitator allowing development of confidence and capacities within the communities. The major risk associated with the model outlined above is that the short term interests of various groups may push the project towards a direction away from the original Purpose for which the project was funded in the first place. But this model is believed to be worth pursuing, when the project staff remains aware of the advantages and limitations of the approach and manage to steer clear the process towards the project objectives. The associated uncertainties, however, are considered unimportant and taken care of suitably when a project is said to be following the process approach.

Participation is an empowering process, a process that progressively gives the local communities an increased control over decision making, resource management and their own development. Increased power for local communities would result in decreased power for the project staff. The major constraints for large scale application of community based development projects are the paucity of trained field staff, allocation of insufficient time frame and more importantly the

unwillingness to transfer decision making power to the communities. Adoption of such a community participation model demands quite a few deviations from the conventional approach of project funding and design.

It is now agreed in principle in almost all quarters that the communities have to play an enhanced and more organized role in managing their natural resources. To this end projects in the future should be designed to involve the communities in planning and execution, as far as possible. The problem, however, arise in actualising this concept. Allocation of suitable roles to the communities and channelizing the community dynamics towards the planned results are definitely the tasks about which we have yet to learn a great deal.

The line departments are still not reconciled to the idea that the communities can be trusted with the serious task of managing their own natural resources. The commonly cited arguments are:

- The illiterate villagers can not grasp the technical complexities of engineering and managing such complex activities.
- The communities are so divided and full of conflicts that they can seldom agree on a common programme.
- Handing over large sums to such communities will either lead to waste or to the advantage of the better off and powerful segments of the rural communities.

Some of these arguments particularly the relevance of villager's knowledge concerning their immediate environment for planning local development works and the notion that villagers will use funds more wastefully and less equitably than the State Government is not tenable.

## **12.5 PROJECT APPROAH**

An ideal *Project Management Plan*, usually highlights a specific development approach, adopts an implementation strategy and shares some common development concerns. If these aspects are not made clear right at the beginning, a great deal of confusions are likely to ensue not only within the project staff but also amongst the communities to be benefited. It is, therefore, important that the project

document not only presents a Project Planning Matrix (PPM) stating the Outputs clearly but also incorporates sufficient explanation on the basic development concepts and terminologies used in articulating these expectations. The adopted project approach should be thoroughly discussed amongst the project staff to arrive at a common understanding on the major issues. Concrete strategies are to be followed in trying to translate these concepts into realities. Some typical project implementation strategy considered useful are discussed below.

### 12.5.1 Process Approach

In the recent years, funding agencies throughout the world have been evincing greater interest in the *process approach* of project implementation as against the conventional project approach. The process approach is the opposite of *blueprint approach* in which the final outcome as well as all that leads to it, are known in advance and are under control of the executing team. Process approach is essentially a bottom-up approach involving greater degree of participation by all stake holders. Process approach may be described as a method which provides for time and space to reconcile the differences between the conceived and the actual socio-economical conditions in the project area and the changes that are taking place during implementation. Process approach allows learning while doing by taking cognisance of the changes that take place in the process. The process approach allows the project team to:

- respond to the yet unknown needs and priorities of the communities;
- incorporate local wisdom and local creativity;
- adopt the approach and planning to the emerging situations and learning during the process;
- allow a step by step development i.e do now what is relevant now, while leaving room for future development;
- include adoptive management practices taking freedom to respond to the local needs;
- adopt different planning methodology taking into account to the physical and social differences between two or more sub-catchments;

Process Approach is particularly relevant to interventions in complicated situations

with many unknown factors, locally varying circumstances and rapidly changing conditions. The main danger in the process approach is that it can lead to frequent changes in project implementation ultimately leading to no definite project Outcome. It is believed that adoption of a project planning matrix with its well defined Outputs, does in no way restrain application of a process approach specially when the processes are managed without losing sights of the project Purpose. In order to avoid the pitfalls associated with process approach, the overall Purpose of the project must be kept in mind and this should be followed with an objective process documentation in a pre-decided format and reinforced by periodical review/monitoring.

### 10.5.2 Bottom Up Approach

The Bottom up Approach (BuA) is a method in which the people are considered to be the driving force behind their own development. The *Bottom up Approach* is the opposite of a *Top down Approach* in which outsiders decides on the development priorities of the target groups. The target group under this approach are encouraged to plan and implement the development activities as per their own capacity under the supervision of the project staff. The project staff is expected to play the role of a facilitator, promoter and supervisor ensuring that the project results remain within the framework of the Project Planning Matrix. The Bottom up Approach, amongst others, is likely to enhance

- local initiatives and knowledge base;
- decision making abilities of the communities;
- contributions to the project (labour, cash, kind, management);
- quality and responsibility for implementation, operation and maintenance.

The bottom up approach

- is initially time consuming but picks up speed when it comes to implementation;
- is useful in developing capacity within the local communities;
- gives a growing sense of dignity among the people as they gain control over their lives;

- facilitates integration of the development initiatives as people see their lives in a more holistic manner than the planners from outside;
- makes the interventions more sustainable;
- helps developing an effective role for the outside actors which is facilitating instead of controlling.

A Bottom up Approach where the communities are at the centre of development, is highly desirable. After all, people can not be "developed" from outside. It is possible, only when the communities imbibe the development initiatives within themselves. The approach allows freedom for the communities to set their own priorities and allowed to make mistakes. This will require patience, understanding and restraint from the funding agency. In this process the external development agency and the villagers will have to be equipped with skills to respond to the local needs and local solutions. Planning for development will not be an one time activity but an iterative process, in which learning and implementation will go on simultaneously.

A limitation of the Bottom up Approach is that in a highly differentiated society, those in power is likely to capture the process and (mis) use it for their vested interests. The possibilities could be minimised by identifying the various interest groups at village level and organising them on the basis of common interests. A further safeguard might be incorporated in the project management plan by phasing the project funding in such a manner that the funding for next phase will be released only after certain level of benefits have been created for some of the identified disadvantaged groups. Finally, initiatives have to be undertaken to ensure that the disadvantaged groups are benefited more than the well off groups.

### 12.5.3 Institutional Approach

The Institutional Approach has the focus on establishment of self-sustained community institutions as the outcome of the development initiatives. The approach gives attention to and makes efforts to strengthen all the relevant organised groups, the way these groups and their members interact within the organization they belong to and also with other organizations. Institutional Approach as such is opposite to the *Construction Approach* where construction of physical structures is considered the mainstay of development. Under this



approach, creation of a strong, self-sustained community institutions is believed to be the key to sustainable development. Development of appropriate norms and procedures in matters relating to interest representation, conflict resolution, decision making, fund handling, local contributions, work supervision, quality control, operation and maintenance etc. are considered important Outputs.

Institutional Approach gives emphasis upon:

- investing in human resource development;
- building strong village based interest groups;
- changing attitudes, skills and approaches amongst the staff members of the Government departments dealing with local development activities;
- developing procedure for the staff of the Government departments to interact in a supportive way with the village interest groups and with their representatives;
- identifying bottlenecks in governmental and donor procedures and sensitising all those concerned towards the need for community empowerment.

The institutional emphasise is useful in situations where the quality of the interaction between various stakeholders is a crucial factor in each of them achieving their goals. The approach is also useful in conservation projects where sufficient control on resource use may be necessary. The draw back of focussing too much on institutions is that it takes a long time before Results become visible. This is particularly the case when the institutions have to be developed from the scratch. Delay in producing visible results also make the communities loose interest in the project. Moreover, these interest groups should be so well organized that they would rather continue to negotiate rather than resorting to violence.

Mismanagement of Institutional dynamics by over-enthusiastic project staff due to lack of experience or due to unrealistic pressure from funding agency with limited local knowledge, may at times cause more damage than good. Inability to manage the conflicts of interest will surely heighten the animosity amongst different groups resulting in neither the formation of sustainable institutions nor much improvement in the natural resources. Also, any direct suggestions made to the staff members

of the State Government line departments to hand over a few basic decision making powers to the community institutions are likely to be met with great resistance. An institutional focus requires long term commitments and patience in the part of all concerned.

## **12.6 PROJECT MANAGEMENT COMMITTEE**

The objective of watershed management would be more than fulfilled if the project helps in establishing a stable resource base (land, water and bio mass) within the watershed wherein the benefits accrued from community resources are being managed and shared by the users through a community controlled institution. For this reason it is imperative that a community organization be formed to look specifically into the aspects of planning, implementation and later the problems and prospects of managing the benefits to be generated from the community assets. Such a village management committee may be called an *Implementation Committee* or a *Watershed committee* depending upon its perceived role.

It is the project implementing agency who has to initiate the formation of such a committee and support the same throughout the project period. A watershed committee may begin operating informally under the leadership of a local leader e.g the ex-Sarpanch, a school teacher or even a well meaning rich farmer under the control and supervision of the project team. The committee is allowed to start planning, followed by implementation as per the existing capacity. During this period, the rules, regulations and other management practices are developed, amended and strengthened. The committee will also be required to evolve a mechanism through which the consensus decisions are arrived at involving the concerned individuals and the groups. The initial leadership may be changed at a later stage, if necessary. Registration of the committee may be considered only at an appropriate time. Major decision making and control of finance related to the project implementation are also to be done at this level of the village committee.

### **12.6.1 Group Formation**

All the people, however, can not address the aspects of natural resource management equally. People have different levels of literacy, knowledge, perception, attitude, capability, resources etc. It is also well known that people tend

to get themselves polarised into various occupational, interest, caste, religion and status groups as per the context of the issue at hand. It is, therefore, important that the project team begins by playing, amongst others, a conscious role in trying to integrate different individuals and communities around common causes. Some times, it is pragmatic to begin with the formation of different interest groups separately, but keeping in mind, the final intention of establishing a broad based village level committee, having wider representation from all sections of the village communities or the groups.

### ***A. Purpose of Groups***

Formation of groups help in dealing with the varied need of each group without antagonizing the larger interest groups. Group formation is therefore the forerunner of mobilizing community participation. The groups could be the functional groups, the users group, the protection group, the youths' group, the women's group etc. The groups

- are the basic social units that are capable of receiving the necessary project inputs;
- provide the ground for developing the need based project activities;
- serve as a social link to interact and negotiate with others groups;
- help individuals in overcoming isolation and allow them to act on matters which was beyond their individual capacity.

### ***B. Basis for Group Formation***

There has to be some basis on which the groups are to be formed. Adopting a common strategy is useful not only to guide the project staff in forming the groups but also helps in analysing the lessons learnt in the process.

- People dependent on particular resources could be formed into a group e.g farmers, landless, herdsmen, artisans, women etc.
- Groups are normally formed from amongst those who are likely to get some direct benefits from the proposed project activities. Attempts should also be made to form separate groups from amongst those who are not likely to

receive any apparent benefits from the project, around other environment friendly income generating activities.

- The micro watersheds or the hamlets could be used as a basis for the formation of groups. In such a case, the groups from the upper micro watershed area should be given higher priority with regards to soil and water conservation measures.
- Groups may also be formed around similar resource endowments e.g all *patta* land holders, all wasteland holders, all marginal farmers etc.

### ***C. Steps Recommended for Group Formation***

Steps recommended for initiating the formation and sustaining the interests of the groups in a village/watershed are:

- Discuss with the people about the basic intents of the project.
- Remain friendly and avoid making impossible promises.
- Highlight important problems of the area and seek solutions.
- Emphasise the importance of forming groups.
- Discuss project components that can be undertaken by the members of a group.
- Identify the potential group leaders.
- Narrate other success stories and organise exposure visits for the local leaders.
- Suggest the groups to lay down basic rules, regulations etc. for undertaking an identified activity.
- Formalise the group and allow them to undertake the mutually identified tasks.
- provide necessary supports the group may want in performing the task at hand.

### **12.6.2 Formation of Project Management Committee**

Groups are considered forerunner for establishing a watershed committee. In a fragmented village society, a watershed committee should ideally be formed, from amongst the nominated group leaders, only after each group has become

sufficiently functional. However, if the people of the watershed are not hostile in their attitudes towards other groups and have sufficient respect for group dynamics, the project may begin straight away by establishing a watershed committee. The formation of the functional groups, in that event, may follow as per the need. The method of formation, functions and the dynamics a small watershed committee and a large group will be more or less the same.

The selection of active members for the watershed committee should preferably be developed only after gathering sufficient information about the potential members. The characteristics of members to be selected preferably be such that there is likely to be sufficient possibilities of:

- voluntary response from the member;
- mutual trust and a sense of self imposed disciplines;
- transparency and flexibility to meet common needs;
- observance of cooperative and democratic principles;
- proper fund management just not only in books but also ethically;
- priority for common interest with no preference to individuals.

#### ***A. Role of the Chief Functionary***

Needless to mention that the performance of the committee will be determined more by its leader than the other members. The chairman of the committee may be elected or selected depending upon the size and coherency amongst the group members. The role of the local committee leader is to:

- identify the needs and priorities of the village;
- develop and stabilize the group dynamics;
- conduct meetings and seek consensus;
- prepare action plans;
- conduct and supervise the group business;
- keep proper records of all transactions;
- develop linkages with other groups and the government departments;
- help in capacity building of the members of the committee/groups.

## ***B. Functions of the Committee***

The basic functions, a well organized watershed committee is expected to perform are:

- Form and present collective decisions on matters related to development priorities.
- Help in the creation of general awareness regarding the need for specific development projects and encourage flow of external assistance to the best advantage of the community.
- Disseminate the implications of the project to the entire community in general and to the direct beneficiaries in particular.
- Help in the implementation of the project to the extent possible.
- Collect contribution from beneficiaries and administer the same towards operation and maintenance of community assets created under the project.
- Support the existing functional groups to remain active and effective.
- Receive and manage funds judiciously.
- Resolve conflicts locally and democratically.

## ***C. Rules and Regulations***

While forming the rule, regulations and bye laws for the watershed committee the following aspects should be kept in mind.

- Criteria for enrolment of membership to the committee.
- Membership fee.
- Sources of funds for the groups and the committee.
- Procedures for electing Governing Body members of the committee.
- Terms for the representatives, their designations, remunerations (if any) etc.
- Responsibilities and rights of the elected representatives.
- Sanctions to be used in case of non fulfilment of obligations.
- Periodicity, purpose and other conducting procedures.
- Requirements for accounting and record keeping.
- Rules which bind the groups, their contributions, obligations etc.
- Basis for sharing of benefits from the project.

- Grounds for expulsion of members, groups and elected representatives.
- Objectives of the individuals, groups vis a vis the committee.

#### ***D. Structure of the Committee***

It is the project team who has to initiate the formation of the watershed committee and provide managerial inputs to sustain the committee during the project period. A watershed committee, to begin with should:

- operate informally under the leadership of a local leader. Registration of the society under an appropriate act should be considered at an appropriate time;
- have wider representation covering all sections of the communities keeping in mind the interests of women and the poorer sections;
- be adequately represented by women;
- have the office bearers elected for a given term than be selected by the members in an informal meeting for an unspecified period;
- have formal rules and regulations worked out and accepted by a majority.

#### ***E. Procedures***

The watershed committee has special functions to perform and is expected to remain non political in nature. it is, therefore, necessary that the committee be different in its structure and functions than that of the village Panchayat. The watershed committee should have a wider representation covering all classes including the ex-members and current members of the village Panchayat, if necessary. The procedures of functioning of the committee should be such that the:

- participation remains open, congenial where decisions are arrived at after taking into considerations of all members;
- language used should be local and understood by all;
- decisions are taken by consensus;
- meetings take place on a fixed day of every month;
- attendance to the meeting made compulsory for the office bearers and open to all other members;
- a working group be formed to analyse results, failures, improvements etc;

- all important matters like the major activities, costs, benefits etc. to be discussed;
- record of discussion be maintained.

### ***F. Precautions***

Decision making and control of finances are to be done at the committee level. For an effective management of funds, the following precautions are suggested.

- Funds are to be kept in a joint Bank account.
- The committee will pass a written resolution to nominate the Bank signatories.
- Banks should be pursued to open an account, even if the committee is not formally registered.
- While one of the signatories will be the chief functionary of the committee, the other may be the project manager or a responsible project staff.
- The cheque book and bank papers and the books of accounts will be kept by the secretary of the committee and shall be made available for scrutiny to any members on demand submitted in writing.

## **12.7 MONITORING**

Project monitoring is continuous or periodical surveillance of the progress of a project. This includes assessment of the project activities in terms of Inputs, Activities, Outputs and External Factors. In other words, It measures, primarily the project progress in relation to the work plan, budget allocation, available Inputs, constraints met with etc. and help adopting corrective measures. Monitoring may also include measuring some higher level Outputs e.g extent of institution development, capacity building, community participation, improvement in environment, reduction in poverty etc.

Monitoring is an essential component of project management. The purpose of monitoring is three fold . Firstly, monitoring assist the project team in effective implementation of the project through continuous review. This in turn makes it possible to bring about the mid term corrections that may become necessary due to



changed situations or other external factors. Secondly, it serves as a mechanism to report to its own central office and to the funding agency whether the progress is taking place as was planned. Thirdly, it provides for a basis and necessary data for documentation of the lessons learned and evaluation of the project performance likely to be conducted at a later stage. Monitoring activities are generally grouped into two broad sections namely the *Internal Monitoring* and the *External Monitoring*.

### **12.7.1 Internal Monitoring**

Internal monitoring is conducted by the implementing agency itself. In fact it is an integral part of project implementation process and hence is required to be carried out regularly. It helps the project implementing agency to continuously review the progress and helps making necessary corrections.. Internal monitoring could be conducted very formally or informally depending upon whether a monitoring plan is in place and is suitably budgeted or not. Such monitoring can take place at two levels namely at the village level and at the project office level.

#### **A. Village Level Monitoring**

Village level monitoring takes place through regular meetings of the watershed committee which is attended by the village communities in general and the target groups in particular. The quality of village level internal monitoring meetings could be assessed by observing the following aspects of the meetings.

- Number and periodicity of monitoring meetings;
- Attendance profile of the members;
- Attitude and behavioural pattern of the participants;
- Degree of participation in the implementation and management;
- Nature of the problems being discussed;
- Capacity to arrive at solutions of the problems being discussed;
- Voluntary attitude in members towards sharing responsibilities;
- Mechanism for sharing the benefits;
- Capacity to resolve disputes amicably;
- Capability of arriving at group decisions.

## **B. Monitoring at Project Office**

Project level monitoring is conducted normally through monthly meetings held at the project office. The field staff from the project sites attend these meetings to report to the project manager. The progresses and the problems being faced are discussed with the project manager and approvals, sanctions, suggestions, guidelines etc. are sought. Although, these meetings aim to be participatory in nature, but the dynamics are generally controlled by the project manager. The outcome of such meetings and consequently that of the project, depends heavily upon the capacity of the project manager to make a balance between a dictatorial stand and allowing consensus decision to rule. The factors listed above for judging the quality of the village level monitoring meetings are equally applicable to judge the quality of such monitoring meetings at the project office. In addition, an evaluation of the project *Monitoring Plan* and perusal of the minutes of the monitoring meetings will give an idea to an external evaluator about the effectiveness of the monitoring practices being followed by the project team.

### **12.7.2 External Monitoring**

This is essentially a requirement of the funding agency and is carried out by the funding agency itself. External monitoring is commonly performed with respect to the work plan prepared by the implementing agency. Regular progress report in a standard format are received from the project office and the progresses achieved are compared with the work plan. This is followed by actual field visits, if necessary. In order to streamline the monitoring efforts, the funding agency may require the implementing agency to prepare a *Project Monitoring Plan (PMP)*.

The other areas of concern usually shared by the funding agency are the book keeping and fund management, reporting and documentation, capacity building and mobilization of community participation. Corrective measures are suggested through discussions during field visits followed by written submissions. Attempts are also made by the funding agency to strengthen an identified areas of weakness associated with the implementing agency. This is done normally through offering training facilities for the project staff and providing services of external consultants.

Major review of the project progresses are done by deputing a mid-term monitoring missions which may be preceded or followed by a review workshop. For an effective external monitoring, the funding agency must work in close cooperation with the implementing agency under a spirit of partnership. The role of monitoring becomes all the more important for projects with multiple Objectives concerning both tangible and intangible benefits.

### **12.7.3 Common Problems in Monitoring**

When a funding agency supports a large number of projects, it is likely that the funding agency will not be able to monitor all these projects, with equal attention. Some common problems encountered by the such funding agencies are:

- Shortage of trained and competent manpower. Monitoring is a specialised task. It requires persons with adequate perspectives and experience which is acquired only through long experience and right attitude.
- Inadequate inter-departmental cooperation and coordination on information exchange within the funding agency. Hard core subject matter specialists when involved in monitoring, may tend to focus on matters related to their own expertise losing sight of other aspects, albeit of equal or greater importance.
- Lack of coordination relating to the progress monitoring, process monitoring and financial monitoring. Not many staff are likely to be equally proficient in all the three areas.
- Lack of Institutional commitments. Sometimes, sufficient attentions are not attached to monitoring because of the assumption that a good project implementing agency, in any case, will implement a project properly and the *vice versa*. This leads to paying more attention on the pre-funding selection and appraisal process than actual on-line monitoring.
- Poor standard of reporting. Many implementing agency fail to provide the necessary information in the desired format despite repeated orientations and reminders.
- Lack of clarity in describing the project objectives and selection of corresponding performance indicators.

In order to monitor a large number of similar projects as a group, organizing joint monitoring workshop has been found useful. The Project Implementing Agencies (PIAs) are required to present their reports on certain common aspects of the project implementation e.g progresses made, problems faced, lessons learnt, funds utilised, documentation prepared, contribution raised etc. When all the agencies reports in a common format, it becomes possible not only to compare relative merits and demerits of each project but also discuss the common problems and seek solutions jointly.

## **12.8 RESULT BASED MANAGEMENT**

An improvised version of LFA which is now known as *Result Based Management* (RBM) was introduced by Canadian International Development Agency (CIDA) during mid-1990 in India. Current emphasis is on applying RBM to all its development projects in India as a package in project formulation, implementation, monitoring and evaluation. The application of the Result Based Management and LFA practices are more or less the same.

### **12.8.1 Results of a Project**

While a project planning matrix based on Logframe has 3 columns and 4 rows, the matrix prepared on the basis of RBM has 4 columns and 3 rows. In other words an extra column for *Results* is included in RBM matrix, in which results are categorised at three different levels and the bottom row containing *Activities* is removed. The three level of Results are known as Outputs, Outcomes and Impacts. While Output results are obtained as the consequences of completion of Activities, the Outcome and Impact results describe achievement parameters corresponding to the Purpose and Goal of the project, respectively.

**Outputs** are immediate, visible, concrete and tangible results produced by direct application of project Inputs.

**Outcomes** are short and medium term results influenced by a combination of project Outputs. They contribute directly to the project Purpose and hence placed at a higher level from Outputs.

**Impacts** are long term results linked to the Goal and are affected by achievement of project Outputs and Outcomes.

While a number of Activities combined together produces an Output, the combined Outputs in turn produce the Outcome which in turn lead to the achievement of project Impact as indicated in the Table below.

<b>End of Activity</b>	<b>Outputs</b>	<b>Outcome</b>	<b>Impact</b>
1a. Tanks constructed 1a. Check dams made	1. Additional water stored	Increased crop production	Increased income for farmers
2a. Field bunded 2b. Lands leveled 2.c Bio mass added	2. Reduced soil erosion	Increased availability of plant produces	
3a. Seedlings planted 3b. Protection and care	3. Increased vegetative cover		

### 12.8.2 Project Planning Matrix

The success or failure of a project can be objectively ascertained only when the results produced at the end of a project are compared with the Results planned at the beginning. In order to make such comparison possible the expected Results of a project are to be defined within the project planning matrix in real and measurable terms together with laying down the Indicators to measure the success.

A typical project planning matrix for a large multi-village integrated watershed management project in a rainfed region of Maharashtra following RBM approach is presented in the Table below.

<b>Goal (Long term objective)</b> Reduction in poverty amongst the rainfed farmers in the region	<b>Impact Result</b> Sustainable improvement in the quantity, quality and productivity of natural resources	<b>Indicators</b> Signs of conservation and restoration in the natural resources become visible	<b>Assumptions</b> Successful NRM models will be adopted by others in the region
<b>Purpose (Immediate objective)</b> Sustainable development of	<b>Outcome Result</b> Improved capacity and confidence of the communities in managing	<b>Indicators</b> The village institutions planned and implemented the project at least to the extent of 80%	<b>Assumptions</b> The right to manage common resources will remain with the

natural resources (land, water, energy, vegetation and livestock) by the communities in x number villages within the watershed	<p>their natural resources</p> <p>Local institutions developed with increased participation of poor and women in planning and decision making process</p> <p>Improved conservation, restoration and productivity of the natural resources</p>	<p>Number, type, structure, function, membership, administrative procedure, decision making process etc. of the local institutions</p> <p>Extent of reduction in soil erosion, increase in soil organic matter, increase in groundwater/soil moisture, reduction in crop failure, increased flow in seasonal streams, increase in fuel, fodder, drinking water etc.</p>	<p>implementation committee</p> <p>The committee will manage the common resources in a pro-poor and pro-women manner</p> <p>The local related State Government line department staff accept and support the project approach</p>
<p><b>Inputs</b></p> <p>Funds</p> <p>Project team</p> <p>Project design</p> <p>Project office</p> <p>Field office</p> <p>Technical staff</p> <p>Consultant</p> <p>Work plan</p> <p>Management</p> <p>Contributions</p> <p>Monitoring</p> <p>Reporting</p> <p>Perspective</p> <p>Leadership</p>	<p><b>Output Result</b></p> <p>Awareness and skills of the communities improved</p> <p>Community endorsed village development plan prepared by the Groups/ Committee</p> <p>Group/Committee members executed part of the project</p> <p>Effective soil and water conservation measures applied as planned</p> <p>Additional area brought under vegetative cover</p> <p>Use of renewable energy and other energy saving practices adopted by the target groups</p> <p>Alternative environment friendly income generating opportunities provided for special groups</p>	<p><b>Indicators</b></p> <p>Number, type and effectiveness of exposure visits and training imparted</p> <p>Quality of the resource maps, planning documents and contents of the plan</p> <p>Extent of involvement , contribution and quality of implementation</p> <p>Number, extent, type, quality, effectiveness, use etc. of the structures and treatment measures</p> <p>Extent, land capability, species, survival rate etc. of the plants and grasses</p> <p>Extent of use, efficiency and demands of such devices</p> <p>Number of such groups, their membership, working capital, management, accruals and contribution towards environment</p>	<p><b>Assumptions</b></p> <p>The time frame allocated is sufficient for mobilizing the communities and at the same time generate the Outputs through community participation</p> <p>The climate and rainfall pattern in the project area remains normal throughout the project period</p> <p>The caste and class conflict within the WS remains manageable throughout the project period</p>

**Table 12.1 Project planning matrix of a sample watershed management project following result based management approach**

It should be noted that in RBM

- A project should have only one Purpose (Immediate Objective). Consequently, a project planning matrix allows stating only one Purpose

statement that too in a brief and concise manner. It does not provide much scope for qualifying how or through what strategy, priority, process, approach etc. the Purpose will be achieved. This sometimes results in the generation of a long Purpose statement with additional qualifications. To avoid this shortcoming, additional information are to be provided in the project formulation document qualifying the Purpose as elaborately as desired.

- The Result statements i.e the Outputs, Outcomes and Impacts must not be described as a process but rather as a state which has already been accomplished. Also, the Outputs should be stated more as the consequence of an Activities rather than just the end of the Activity e.g not as “construction of check dam completed” but rather as “excess surface water made available”.
- While the Outputs are the Results which must be produced by the project management, the Outcomes will be achieved only if the Assumptions are fulfilled satisfactorily. The control of the project team in achieving the Outcomes are at a reduced level but nevertheless the project team can exert necessary influence to make Outcomes happen. Impacts are the highest level of Result on which the project management has least control.
- The Indicators to be used for monitoring a project should necessarily be objectively verifiable. The Indicators stated in the above example are brief and indicative in nature due to paucity of space. For the sake of monitoring, these Indicators are to be expanded further incorporating additional qualifications like how much, by when, for whom, to what quality etc. Some typical examples are a) at least 3 groups are formed in each village by year 1 to undertake soil conservation work in private lands b) At least 200 ha community wastelands in village xyz are brought under plantation for fuel and fodder species by year 2 for the benefit of the abc communities c) at least 80% of the village natural resource development plan have been implemented by the groups/ watershed committee.
- Means of Verification reminds us how effectively the Indicators can be measured. Means of Verification for qualitative Indicators attract greater interest than the quantitative ones particularly when used for project evaluation.
- The Assumptions need to be monitored and managed as far as possible as

the implementation proceeds. Efforts should also be made to make the Assumptions happen, If the project team can in any way influence the same.

- The project planning matrix to be prepared following Result Based Management approach does not have any provision for listing the Activities. This is because the emphasis of RBM is on the Outputs and not on the Activities. It is recommended that the Outputs of a project are first stated in clear and achievable terms and only then the necessary Activities are identified and undertaken so as to generate these Outputs.

### **12.8.3 Use of Indicators**

Both quantitative and qualitative values are assigned to the Indicators as appropriate that will set performance standard (target) for each Result to be achieved. These target values should be assigned very carefully as these will serve as the cut-off values which will finally determine a project successful or failure. Assigning proper values to the Results for defining success are critical and hence these should neither be too high or too low. Once the Indicators are selected these have to be continuously monitored to follow the progress being made. The project management plan should, therefore, keep provision for data collection which could be used to measure the Indicators. The provision for data collection should lay down clearly the type of data to be collected, their sources, frequency, reliability, cost etc.

Outputs are measured more often by quantitative Indicators. Use of quantitative Indicators to measure the physical changes directly, particularly the Outputs, is rather straight forward task. For example, the quantitative Indicators like “area brought under vegetative cover”, “additional water stored in a water harvesting structure”, “number of functional groups formed” etc. can be verified easily. The qualitative aspects of quantitative Indicators could be brought about by adding additional qualifications e.g 500 ha wastelands have been brought under vegetative cover with 5 fuel wood and 7 fodder species giving 80% survival rate.

Use of quantitative Indicators, particularly at the Outcome level, appears simple in its concept but use of such Indicators demand supportive data involving a great deal of time and resources to collect the same. For example, quantitative Indicators like “extent of reduction in soil erosion” can be measured quite accurately by



installing stream gauging station which is not only expensive and time consuming but also requires specialized man power. Similarly, “extent in improvement in groundwater recharge” can be established only after monitoring the water level in a number of observation wells for a minimum period of one year. The qualitative aspect of the quantitative Indicators is brought about by adding qualifications like “to what percentage”, “at which location”, “by which year”, “for which target group” etc. e.g 75% reduction of soil loss observed at the outlet of the watershed by year 3. To measure these changes using Indicators requires a base line data from which such changes are measured.

Qualitative Indicators on the other hand, could be direct or indirect. For example, an Indicator like “the extent of contributions given by the beneficiaries” e.g time, ideas, labour etc. may be used as a direct qualitative Indicator for measuring “ the ownership of the target group towards the project”. Similarly, “the quality of planning and implementation” may be used as a direct qualitative Indicator for “capacity building”. Terms like “sufficient”, “improved”, “enhanced” etc. are used for quantifying the qualitative Indicators.

Use of indirect qualitative Indicators are not only difficult in their concepts but also are difficult to apply. Such Indicators are normally used for Impact level results e.g. “increase in demand for consumer goods” is an indicator of “increased income”. Use of Indirect qualitative Indicators, however, are to be applied with certain amount of subjectivity as these are based on one or more than one assumptions. For example, “extent of women attending and voicing opinions in village meetings” may be taken as an indicator of “increased awareness amongst women”.

An effective way of selecting Indicators is to ask the question what do we need to monitor in order to effectively manage the project towards Results. Progress may be measured from a baseline data to compare current situation with the past situation in absolute terms. Certain physical Outputs, however, can be measured even without any base line data e.g 5 new water harvesting structures constructed, 100 ha additional lands brought under plantation etc.

Another difficulty met with in using Indicators is to ascertain whether the changes observed are due to the project intervention or other wise. For example, in a

watershed development project, “the observed increase in crop yield” may be because of application of more fertilizer and/or use of high yielding variety of seeds which were not part of the project intervention. These type of difficulties faced in monitoring is rather theoretical in nature and limited to application of logic. In field situation it may not be very difficult to ascertain the causes for increase in crop yield after having a discussion with the local farmers. In order to make assessment of relative progress more acceptable, attempts are also made to compare the conditions of the project area at the end of the project period with another similar area (control area) where no such project interventions have been undertaken.

It should be noted that use of Indicators for higher level results have their own associated limitations. Performance of all types of projects can not be measured solely in terms of performance Indicators. Indicators are a step towards a wider analytical process giving signals for objective judgments. Indicators are no substitute for sound judgment and adequate project management.

#### **12.8.4 Project Monitoring Plan**

A good monitoring plan not only takes into account the Activities but also keeps a tab on how completion of these Activities are actually contributing towards achieving the Outputs and the Outputs towards the Outcomes. Use of a standard format for monitoring the Outputs have been found to be quite useful. This is normally done by listing the major Outputs of the project in a tabular form and then allocating against each Output, a time frame, a budget, other Inputs required and the person(s) responsible for achieving these tasks. A periodical review of this table not only provides at a glance how the project is performing but also helps in identifying areas that need strengthening.

The basic steps needed to be followed in developing an effective Project Monitoring Plan are:

- Convert the basic project intents into a project planning matrix following Logical Framework Approach (LFA).
- Ensure that the Output and outcome statements have been defined in real, achievable and measurable terms. Fine tune the statements, if necessary.

Usually 5-10 Output statement and 3-5 Outcome statements are good enough.

- Identify the Indicators to be used to measure/monitor each of these Outputs and the Outcomes. Add quantitative and qualitative attributes to the Indicators.
- Review if the proposed quantity and the quality attributed to the Indicators are achievable so as to arrive at the final target. The success/failure of the project in the future will be measured against these set targets.
- Prepare a broad Work Plan for the entire project period including all the major Activities.
- Prepare a more specific and elaborate work plan with associated time lines for the period for which detail monitoring is proposed i.e quarterly, half yearly or annually.
- Ensure that each of the major Activities proposed in the work plan contribute directly in achieving the Outputs one way or the other. Group the sub-Activities under a few major Activities. Also tag completion of a few major Activities as the completion of the “milestone Activity”
- Establish a monitoring mechanism which is usually a review meeting, its frequency and a Format for recording the findings.
- Evaluate using the Indicators, how much the completed Activities have actually contributed in accomplishing the Output targets. Record these findings in a standard Format.
- Discuss in the monitoring meeting the achievements and the short falls ascertaining reasons for the same.
- Incorporate corrective measures as considered appropriate. Scale up or scale down a particular Activity as per available resources and identified needs and priorities. Add new Activities or drop some of the on-going Activities, if necessary.
- The last three steps are repeated throughout the project period.

Although, designing a standard Format for monitoring depends upon the need and priorities of the project, a typical format for reporting monitoring results are presented below.

<b>Description</b>	<b>Target for this reporting period</b>	<b>Proposed Budget</b>	<b>Target actually achieved</b>	<b>Actual cost incurred</b>
<b>Output # 1</b> Activity # 1a Activity # 1b Activity # 1c .....				
<b>Output # 2</b> Activity # 2a Activity # 2b Activity # 2c .....				

**Table 12.2 A standard format for monitoring project Outputs**

## **12.9 EVALUATION**

*Evaluation* refers to assessment of the performance, efficiency and impact of a project in the context of its stated objectives. This is a systematic and independent examination of the performances of a project and its overall efficiency in administering the Inputs. Evaluation is usually a need of the funding agency and could be conducted during interim (mid term) or post implementation period. The task of evaluation becomes easier when base line data have already been collected for this purpose. In the absence of base line data evaluations are conducted subjectively as per the past experience of the evaluator and by using appropriate Impact Indicators. Evaluations are conducted based on field visits, discussions with the project staff , the target groups and analysis of the reports and records (monitoring data).

### **12.9.1 Purpose of Evaluation**

The purpose of evaluation is to learn how the project had performed against the planned measures. While monitoring is considered to be useful in making improvements in an on going project, evaluation is essentially *post mortem* in nature. Interim evaluation makes an appraisal of the progress made in terms of physical achievements, organizational efficiency, fund management, quality and quantity of benefits accrued, beneficiary responses etc. at the end of a particular phase of the project cycle. Interim evaluation is used in deciding whether the

project should be extended to its next phase or not and if so then what corrective measures are to be incorporated in order to bring about qualitative improvements in future project execution.

Post implementation evaluation are conducted at the end of the project period to study if the objectives (Purpose and Goal) of the project have been achieved and if so what are their Impacts. The primary objective of post implementation evaluation is to analyse the processes through which the project had gone through and assign responsibilities (failure/success). This is also considered a valuable learning process which will have its use in designing future projects.

Evaluation is normally done by a group of experts. The role of these experts are defined in their Terms of Reference (ToR). Preparation of a ToR is important because there may be some experts in the evaluation team who might fail to appreciate the depth of preparation, labour and efforts that had gone into the project implementation and might be eager to be critical in their judgements. In order to show their knowledge and justify their role, they may come up with a long list of what have not been achieved but should have been achieved by the project. Evaluations, if not done in the right perspective may turn out to be counter productive to the entire efforts. Though carried out by a group of external observers, the quality of evaluation improves when attempts are made to conduct the same in a participatory manner.

### **12.9.2 Focus of Evaluation**

No performance evaluation i.e the assessment of the achievements and the shortfalls of a project implementing team may be considered to be complete without an adequate assessment of the project design (expectations). Evaluation draws on the information obtained from monitoring and try to evaluate why things went the way they did. Just as evaluation is directly linked to monitoring, monitoring should be integrally linked with the project design. Use of Result Based Management approach in project design becomes useful in rendering an evaluation more objective. What really needs to be looked into in performance evaluation is whether the team members made sufficient efforts to identify the opportunities and applied the limited available Inputs at their disposal to its best possible return. An evaluation team, amongst others, may

- focus on the major achievements;

- determine how correctly the strategies and the operational procedures were used for attaining the objective;
- locate the reasons and the situations when project implementation changed from the planned measures;
- assess the nature of the changes and consequences they have resulted;
- document findings and analysis these for future reference;
- assess the aspects of efficiency in the application of Inputs and their over all impacts.

### **12.9.3 Evaluating the Evaluators**

It is but natural that all evaluations will not be conducted with equal degree of proficiency. A poorly presented evaluation report can cause a lot of damage to the morale of an otherwise normally performing project implementing team. In practice, evaluations are carried out following a Terms of Reference (ToR) prepared by the funding agency. It is, therefore, important that the ToR be prepared in a balanced manner providing sufficient opportunities to bring out the project achievements. The draft evaluation report should be discussed and accepted with sufficient objectivity. Instead of demoralising the project implementing team successfully, evaluations will serve a meaningful purpose only when the findings of the evaluation team are analysed and presented in the form of recommendations to be incorporated in planning and designing of future projects. Some basic questions that need to be addressed in evaluating the evaluation procedure and the performance of an evaluation team are:

- were the evaluation needs adequately perceived;
- were the objective of the Evaluation sufficiently clear;
- what were the focus on short term and long term effects/benefits;
- was a formal evaluation procedure established, a time table set up;
- what were the techniques used for benefit-cost, performance assessment;
- who did the evaluation, an individual or a team, an insider or an outsider, composition of the team;
- what levels of experience the evaluators have;
- was adequate background information provided to the evaluator;
- were adequate administrative supports available to the evaluators;
- has the intended results of the evaluation achieved;
- what are the major factors for causing delay, cost over-run, inability in

- meeting the performance criteria;
- did the evaluators identify replicable components;
- was there any unfortunate side effects;
- were the project staff discussed with the interpretations of the evaluation team and their major findings;
- were the lessons learnt and insights gathered presented;
- how would these lessons be applied in future in designing a similar project;
- how these lessons will be applied to future project managements;

## **12.10 WITHDRAWAL STRATEGY**

A common issue encountered in almost all rural development projects as it approaches closer to its end, is how to sustain the project benefits that has already been generated during the project period. As the project inputs start getting reduced, the beneficiaries start feeling the crunch. Unless the beneficiaries are prepared for this day, many of the benefits created will simply start collapsing as soon as the project team withdraws from the village. A sustainable project development will demand that the benefits generated during the project period continue to accrue long after the project team has withdrawn from the area. To make a project sustainable, it is essential that not only the benefits of the project are handed over to the communities but also the communities are made capable enough to take charge and manage the same effectively.

The project team should bear in mind all throughout the project period that it has to play basically a promotional role. For this, a well laid down withdrawal strategy should be developed and made operational as part of the project implementation. In fact, the process of empowerment must begin from the day one. Community empowerment implies that by the time the project team withdraws from the project area, the communities have become capable enough to take charge and manage the benefits of the project of their own. In fact, it will relatively be more desirable for a project rather to generates less benefits in a more sustained manner rather than generate quick benefits that vanish with the withdrawal of the project team. Therefore, the total project period should preferably be divided suitably into three major phases namely the preparatory phase, the implementation phase and the withdrawal phase.

## REFERENCES

Agriculture Finance Corporation (AFC) (1988): Report on Evaluation Study of Soil Conservation in the River Valley Project of Matatila, Department of Agriculture and Cooperation, MoA.

All India Soil and Land Use Survey (AISILUS) (1990): National Watershed Atlas, All India Soil and Land Use Survey (AISLUS), Department of Agriculture and Cooperation, New Delhi.

Balakrishnan (1996): Watershed Development, Proceedings of DANIDA International Workshop on Watershed Development, WDC Publication, New Delhi.

Bali, J.S. (1988): 'Soil Conservation Research', Journal of the Soil and Water Conservation Society of India.

Chambers, R. (1991): Shortcut and Participatory Methods for Gaining Social Information For Projects, in Michael, M. (Ed.) Putting People First: Sociological Variables in Rural Development, World Bank, Oxford University Press.

Chambers, R. and Irene, G.(1995): 'PRA---5 years later: Where are we now' Wastelands News, Nov. 95—Jan. 96, SPWD, New Delhi.

Chaturvedi, A.N. (1984) : Management of India's Forest Resources, Khanna Bandhu, Dheradun.

Dhruvanarayan, V.V., Babu, R. (1983): 'Estimation of Soil Erosion in India', Journal of Irrigation and Drainage Engineering, ASCE 109 (4).

Finkel, M (1985): Turkana, Water Harvesing Manual, Finkel and Finkel, Consulting Engineers, Israel.

Gregersen, H.M., H.M., Brooks, K.N., Dixon, J.A. and Hamilton, L.S. (1987): Guidelines for economic appraisal of watershed management project, Food and Agriculture Organization of United Nations, Rome.

Hocking, Drake (Ed.) (1993): Trees for Drylands, Oxford and IBH Publishing Co. Pvt. Ltd., New Delhi.

Handbook of Agriculture (1992): Indian Council of Agriculture Research, New Delhi.

Jensen, J.R. (1996): Watershed development, Proceedings of DANIDA International Workshop on Watershed Development, WDC publication, New Delhi.



Michael, A.M. (1978): Irrigation: Theory and Practices, Vikas Pub., New Delhi.

Ministry of Agriculture (MoA) (1992): National Watershed Development Project for Rainfed Areas (NWDPR), Guidelines, Department of Agriculture and Cooperation, Government of India, New Delhi.

Raju, K.C.B. (1995): Groundwater resource of Kutch district, necessity for its proper management.

Reddy, Ramakrishna K. (1995): Irrigation and Agriculture Development in India, Ashish Publishing House, New Delhi.

Ramulu, U.S.S. (1995): Dry Farming in India, Oxford and IBH Publishing Co. Pvt. Ltd, New Delhi.

Sarin, M. (1996): Joint Forest Management, The Haryana Experience, Environment and Development Series, Centre for Environment Education, Ahmedabad.

Seth, S.L. (1996): Watershed development, Proceedings of DANIDA international workshop on watershed development, WDC publication, New Delhi.

Singh, Gurmel et al (1990), Manual on Soil and Water Conservation Practices. CSWCR&TI, Dehradun.

Soil Conservation Society of America (SCSA) (1982): Resource Conservation Glossary (3<sup>rd</sup> ed.), Iowa, USA.

Todd, D.K. (1959): Groundwater Hydrology, John Wiley and Sons Inc., New York.

Vaidyanathan, A. (1991): Integrated Watershed Development: Some Major Issues, Foundation Day Lecture, Society for Promotion of Wastelands Development, New Delhi.

Wastelands development and their utilization (1998): Scientific Publishers, Jodhpur, ed. K.A. Shankaranarayan.

ANNEXURE I

## Format for Resource Inventory in a Watershed for the Preparation of Technical Plan

### 1.0 General :

Name of the Watershed : .....

Total area of the Watershed : .....

Number of Villages : .....

Average Rainfall : Monsoon (Jun-Oct): .....

Non-monsoon (Nov-May): .....

Average Evaporation: Monsoon:.....

Non-monsoon:.....

### 2.0 Demographic distributions

Village	Area, ha	Population			Total
		Male	Female	Child	

### 3.0 Land use in the micro-watershed

Land use	Area, ha	Land use	Area, ha
Forest land:	.....	Grazing land	.....
Cultivated area:	.....	Orchards	.....

Area under Kharif only : .....	Area under hills : .....
Area under Rabi only : .....	Area under water bodies: .....
Area under double crop : .....	Inhabited area: .....
Private waste : .....	Fallow land : .....
Common waste : .....	Other: .....

#### 4.0 Land holding pattern in the micro-watershed

Big farmer	Medium farmer	Small farmer	Marg.farmer	Patta holders	Landless
(> 5 ha)	(2-5 ha)	(0.5-2 ha)	(< 0.5 ha)		

---

#### 5.0 Land Capability Class

Capability class	Village 1, ha	Village 2, ha	Village 3, ha
I			
II			
III			
IV			
V			
VI			
VII & VIII			
TOTAL			

#### 6. Agriculture/Crop related data

---

Type of crops	Irrigation depth & number	Fertilizer kg/ha	Average yield tones/ha
<b>Kharif</b>			
a.			
b.			
c.			
d.			
e.			
<b>Rabi</b>			
a.			
b.			
c.			
d.			
e.			
<b>Summer/vegetables</b>			
a.			
b.			
c.			

## 7. Water resources inventory

Source	Number/length	Crops	Area irrigated
<b>Wells</b>			
a. Perennial :			
b. Seasonal :			
<b>Bore/Dug cum bore wells :</b>			

**a. Perennial :**

**b. Seasonal :**

**Ponds/Tanks**

**Canal :**

**Streams :**

**a. Perennial :**

**b. Seasonal :**

**Others (specify)**

---

## **8. Livestock details**

---

<b>Cow</b>	<b>Buffalo</b>	<b>Bullock</b>	<b>Sheep</b>	<b>Goat</b>	<b>Others</b>
------------	----------------	----------------	--------------	-------------	---------------

---

**Village 1:**

**Village 2:**

**Village 3:**

---

## **9. Plantations**

---

<b>Village</b>	<b>Forest area :</b>	<b>Farm lands :</b>	<b>Road side :</b>
	<b>Species :</b>	<b>Species :</b>	<b>Species :</b>
	<b>Density:</b>	<b>Density:</b>	<b>Density:</b>

---

**ANNEXURE II**

**Questionnaire Seeking Pertinent Details about a Voluntary Agency Intending to Implement Watershed Management Projects.**

**1.1 Name of the Organization :**

.....

.....

**1.2 Address**

**1.2.1 Main Office :**

.....

.....

.....

.....

**1.2.2 Field Office :**

.....

.....

.....

.....

**1.3 Legal Status**

**1.3.1 Registered Under:**

.....

.....

**1.3.2 Registration Number:**

.....

**1.3.3 FCRA Number:**

.....

**1.3.4 Year of Establishment:**

.....

**1.4 Bank**

**1.4.1 Name:**

.....

.....

**1.4.2 Address:**

.....

.....

.....

**1.4.3 Name of Account:**

.....

.....

**1.4.4 Account Number (FCRA):**

.....

**1.4.5 Account Numbers (Others):**

.....

**1.4.6 Authorised Signatory**

**Name**

**Designation**

1. \_\_\_\_\_
2. \_\_\_\_\_
3. \_\_\_\_\_

**1.5 Composition**

**1.5.1 Office Bearer**

<b>Name</b>	<b>Designation</b>	<b>Qualification</b>
<b>Experience</b>		
1.	_____	_____
2.	_____	_____
3.	_____	_____
4.	_____	_____
5.	_____	_____
6.	_____	_____
7.	_____	_____

**1.5.2 Key Staff**

<b>Name</b>	<b>Designation</b>	<b>Qualification</b>
<b>Experience</b>		
1.	_____	_____
2.	_____	_____
3.	_____	_____
4.	_____	_____
5.	_____	_____

**1.5.3 Name of the Chief Functionary:**

\_\_\_\_\_



**1.5.4 Aims and Objectives:**

---

(Please enclose copy of MOA if necessary)

**1.6 Experience**

(Enclose separate sheet if necessary)

**1.6.1 Experience in Development Work in General**

---

---

---

**1.6.2 Experience in Soil and Water Conservation works**

---

---

---

---

---

**1.7 Financial Management**

**1.7.1 Average Annual Expenditure**

---

(Separate for last 3 years)

**1.7.2 Budget for the Current Year:**

---

**1.7.3 Sources of Current Funding:**

---

**1.7.4 Accounting Staff**

---

**Name**

**Nos.**

**Qualifications**

---

---

**1.7.5 Audit Practice Followed (Please enclose copies): YES/NO**

**1.7.6 Name and Address of Auditor:**

---

---

**1.8 Reporting**

**1.8.1 Annual Report (Please enclose copies): YES/NO**

**1.8.2 Any Other Report:**

**1.9 Existing Infrastructure**

**Main assets:**

**Office Building:**

**Vehicle:**

**Documentation equipment:**

**Demonstration Plot:**

**Training centre and material:**

**Computers and software:**

**Telephone/Fax**

**Others**

**1.10 Remarks**

**(Please add separate sheet if necessary including details of pending or past court cases, if any)**

**Signature:**

## ANNEXURE III

### Conversion Tables

#### A. Area

Sq. metre	Hectare	Sq. Km	Sq. mile	Acre
1	0.0001	0.000001	0.00000038	24710
10,000	1	0.01	0.0038	2.471
1,000,000	100	1	0.3861	7.1
2,590,000	259	2.59	1	640
4047	0.4047	0.00405	0.00156	1

#### B. Volume

Litre	Cubic metre	Imp-gallons	US-gallons	Acre-ft
1	0.0001	0.220	0.264	$0.81 \times 10^{-6}$
1000	1	220	264	$0.81 \times 10^{-3}$
4.546	0.004546	1	1.20	$0.45 \times 10^{-6}$
3.79	0.00379	0.833	1	$0.38 \times 10^{-6}$
1233500	1233.5	271542	325644	1

#### C. Discharge rate

Litre/sec	Litre/min.	Cu.m/hr	Imp-gal/hr	US-gal/hr
1	60	3.6	782.08	950.83
0.0166	1	0.06	13.19	15.84
0.277	16.66	1	220	264
0.00126	0.0757	0.004546	1	1.2
0.001	0.063	0.00379	0.833	1

### *About the author*

Dr. Mihir Kumar Maitra completed his Master's in Earth Science from Indian Institute of Technology, Kharagpur in 1972. He served in Action for Food Production (AFPRO) in its Groundwater Investigation Teams in different parts of the country for 18 years during which he also obtained his PhD in Hydrogeology. He left AFPRO as its Head, Water Resources Development department to join Indo German Bilateral Project – Watershed Management (IGBP-WSM) as a Project Engineer. During this period, he worked mostly on Soil and Water Conservation works in association with Ministry of Agriculture . Three years later, he joined Eco Tech services (ETS) where he was involved in preparing Technical Plan of two Watershed Development projects in Madhya Pradesh. After another three years, he joined India Canada Environment Facility (ICEF) as a Senior Project Manager where he worked for about ten years in facilitating formulation, implementation, monitoring and evaluation of Natural Resource Management projects implemented by a dozen of large National level Non Government and State Government agencies.