

Groundwater

Fourth Edition



American Water Works
Association

Groundwater

Fourth Edition



**American Water Works
Association**

Manual of Water Supply Practices—M21, Fourth Edition

Groundwater

Copyright © 1973, 1989, 2003, 2014 American Water Works Association

All rights reserved. No part of this publication may be reproduced or transmitted in any form or by any means, electronic or mechanical, including photocopy, recording, or any information or retrieval system, except in the form of brief excerpts or quotations for review purposes, without the written permission of the publisher.

Disclaimer

The authors, contributors, editors, and publisher do not assume responsibility for the validity of the content or any consequences of their use. In no event will AWWA be liable for direct, indirect, special, incidental, or consequential damages arising out of the use of information presented in this book. In particular, AWWA will not be responsible for any costs, including, but not limited to, those incurred as a result of lost revenue. In no event shall AWWA's liability exceed the amount paid for the purchase of this book.

Project Manager/Senior Technical Editor: Melissa Valentine
Senior Manuals Specialist: Molly Beach
Senior Production Editor: Cheryl Armstrong

Library of Congress Cataloging-in-Publication Data

Bloetscher, Frederick.

Groundwater / Frederick Bloetscher. -- Fourth edition.

pages cm -- (AWWA manual ; M21)

Includes bibliographical references and index.

ISBN 978-1-58321-964-5 (alk. paper)

1. Groundwater. 2. Wells. I. American Water Works Association. II. Title. III. Title: Ground water.

TD403.B56 2014

628.1'14--dc23

2013031069

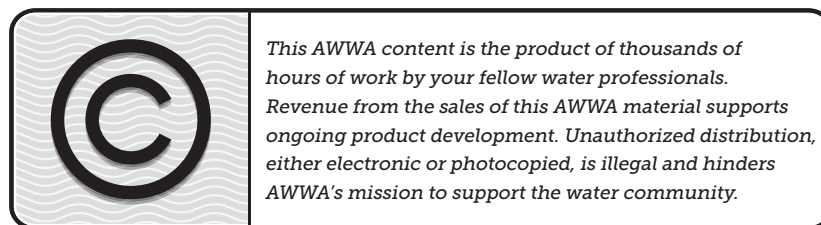

ISBN: 978-1-58321-964-5

eISBN: 978-1-61300-243-8

Printed in the United States of America

American Water Works Association
6666 West Quincy Avenue
Denver, CO 80235-3098
awwa.org



Contents

List of Figures, vii	
List of Tables, xi	
Foreword, xiii	
Acknowledgments, xv	
Chapter 1 The Occurrence and Behavior of Groundwater.....	1
Hydrologic Cycle, 2	
Groundwater Concepts, 6	
Major Conditions That Impact Groundwater, 10	
Achieving Sustainability, 12	
References, 13	
Chapter 2 Evaluation of Groundwater Conditions	15
Suitable Groundwater Supplies, 16	
Locating Suitable Groundwater Supplies, 18	
Monitoring Groundwater Quality, 27	
Field Logistics and Documentation, 30	
References, 33	
Chapter 3 Groundwater Management and Protection	35
Introduction, 36	
Regulatory Level Management, 36	
Source Water Protection, 38	
Management Strategies, 40	
Contaminated Groundwater Management, 41	
Regional Groundwater Management, 42	
Groundwater Sustainability, 44	
Future Groundwater Management, 49	
References, 49	
Chapter 4 Quantitative Evaluation of Wells.....	51
Aquifer Parameters, 51	
Storage Coefficient, 64	
Collection of Test Data, 67	
Analysis, 67	
References, 76	
Chapter 5 Wells—Types, Construction, Design, and Use.....	79
Types of Wells and Their Construction, 79	
Common Construction Components, 95	
Well Design Procedure, 122	
Sanitary Protection, 122	
Well-Field Design, 123	
Well Losses, 125	
Radial-Well Yield, 127	
Modeling Techniques, 127	
References, 133	

Chapter 6	Well Pumps and Pumping	135
	Pump Classifications, 137	
	Operating Conditions, 153	
	Pump Selection, 155	
	Electric Motor Selection, 158	
	Pump Installation, 158	
	References, 160	
Chapter 7	Operations Problems, Well Plugging, and Methods of Correction	161
	Evaluating Well Performance, 162	
	Poor Well Performance, 163	
	Common Pump Operating Problems, 164	
	Physical Causes of Well Deterioration, 166	
	Sand Pumping, 168	
	Microbiological Fouling, 169	
	Treatment of Fouling Problems, 172	
	Economics of Cleaning Plugged Wells, 175	
	Case Studies, 178	
	References, 188	
	Additional Reading, 189	
Chapter 8	Groundwater Quality	191
	Chemicals in Groundwater, 191	
	Groundwater Contamination, 195	
	Chemical Contaminants, 197	
	References, 204	
Chapter 9	Groundwater Treatment	207
	Aeration, 207	
	Oxidation, 209	
	Softening and Ion Exchange, 211	
	Filtration, 215	
	Adsorption and Absorption, 217	
	Corrosion Control, 218	
	Disinfection, 221	
	Fluoridation, 222	
	Membranes, 222	
	References, 225	
Chapter 10	Record Keeping	227
	Design and Construction Records, 227	
	Pump Data, 230	
	Well Acceptance and Pumping Test, 235	
	Monthly Pumpage, 235	
	Water Levels, 237	
	Water Temperature, 237	
	Specific Capacity, 237	
	Differential, 237	
	Well Maintenance, 238	
	Well Abandonment, 238	
	Records Filing and Maintenance, 238	

Chapter 11 Groundwater Recharge and Storage Programs.....239
Underground Protection Criteria and Standards, 240
Aquifer Storage and Recovery, 241
Aquifer Reclamation, 247
Artificial Aquifer Creation and Recharge, 252
References, 258

Chapter 12 The Future of Groundwater261
Reference, 263

Glossary of Terms, 265

Index, 269

List of AWWA Manuals, 279

This page intentionally blank.

Figures

- 1-1 Hydrologic cycle, 2
 - 1-2 Evapotranspiration rates, 3
 - 1-3 A comparison of ET rates and rainfall in South Florida, 4
 - 1-4 One-hour rainfall (inches) to be expected once on average in 25 years, 5
 - 1-5 Average annual precipitation (inches) in the United States (1961–1990), 5
 - 1-6 Water movement below the earth's surface, 7
 - 1-7 Geologic configuration of aquifers and confining beds, 8
 - 1-8 Groundwater movement as it relates to topography, 9
 - 1-9 Development of a cone of depression, 9
 - 1-10 Areas where land surface subsidence is an issue, 11
-
- 2-1 Schlumberger and Wenner electrode arrangements for measuring earth resistivity, 20
 - 2-2 Application of seismic refraction method for reconnaissance mapping, 22
 - 2-3 Single-point electrode arrangement for resistance and spontaneous potential logging, 25
 - 2-4 Qualitative interpretation of a suite of geophysical logs, 27
 - 2-5 Schematic of a multiple-completion monitoring well, 29
 - 2-6 Graphic detail of a hydrogeologic cross section, 31
 - 2-7 Predevelopment groundwater contours showing potential contamination source downgradient, 32
 - 2-8 Predevelopment groundwater contours showing predicted effects of ill-advised development, 32
-
- 3-1 Example of a surface activity that could affect groundwater through a leaky storage tank, 37
 - 3-2 Broward County source water protection zones, 39
 - 3-3 Groundwater management factors, 41
 - 3-4 Options to address contaminated aquifers, 42
 - 3-5 Difference between average annual precipitation and potential ET rates, 45
 - 3-6 Water deficit areas , 46
 - 3-7 Water available for recharge throughout the United States, 46
 - 3-8 Water-level declines, 47
-
- 4-1 Theoretical cube, 52
 - 4-2 Definition of porosity, 53
 - 4-3 Definition of specific yield and specific retention, 53
 - 4-4 Definition of heads and gradients, 55
 - 4-5 Example well location to be used in determining direction of groundwater movement and hydraulic gradient, 56
 - 4-6 Steps in determining direction of groundwater movement and hydraulic gradient, 56
 - 4-7 Definition of hydraulic conductivity, 58
 - 4-8 Hydraulic conductivity of selected rocks, 59
 - 4-9 Definition of capillarity and unsaturated flow, 59
 - 4-10 Determining capillary gradient from tensiometer measurements of hydraulic pressures, 61

- 4-11 Relation between degree of saturation and the ratio of saturated and unsaturated hydraulic conductivity for coarse sand, 61
- 4-12 Definition of transmissivity, 63
- 4-13 Calculation of transmissivity using stream discharge, 64
- 4-14 Definition of storage coefficient, 65
- 4-15 Hypothetical test situation—infinite aquifer, 69
- 4-16 Hydrograph for observation well No. 1, 70
- 4-17 Drawdown test data superimposed on Theis-type curve, 72
- 4-18 Straight-line approximation of drawdown data analysis, 72
- 4-19 Hypothetical test situation—aquifer bounded by impermeable barrier, 73
- 4-20 Effect of impermeable barrier shown on straight-line drawdown plot, 74
- 4-21 Hypothetical test situation—aquifer bounded by recharging stream, 74
- 4-22 Effect of recharging stream shown on straight-line drawdown plot, 75

- 5-1 Dug well, 81
- 5-2 Typical cable-tool method of drilling to remove cuttings, 84
- 5-3 Rotary method of well drilling, 85
- 5-4 Down-hole hammer, hammer drilling, 86
- 5-5 Reverse-circulation rotary method, 87
- 5-6 Dual-rotary drilling, 88
- 5-7 Two phases of gravel-wall well construction—gravel envelope method, 91
- 5-8 Details of a radial well, 92
- 5-9 Riverbank filtration using vertical wells, 94
- 5-10 Riverbank filtration using horizontal wells, 94
- 5-11 Scale of screen-opening sizes, 103
- 5-12 Cross-sectional comparison of well walls, 104
- 5-13 Details of cylindrical plummet, 113
- 5-14 Suspension of the plummet using drill rig, 113
- 5-15 Longitudinal projections of wall and constructed pump centerlines on north–south and east–west vertical planes, 115
- 5-16 Graphic representation of requirements of plumbness in Figure 5-15, 116
- 5-17 Graphic representation of requirements for alignment in Figure 5-15, 116
- 5-18 Relationship between misalignment diameter from Figure 5-15, effective diameter of the well, and inside diameter of the well, 117
- 5-19 Type 1, 118
- 5-20 Type 2, 118
- 5-21 Type 3, 118
- 5-22 Type 4, 118
- 5-23 Type 5, 119
- 5-24 Type 6, 119
- 5-25 Type 7, 119
- 5-26 Type 8, 119
- 5-27 Type 9, 119
- 5-28 Type 10, 119
- 5-29 Type 11, 120
- 5-30 Type 12, 120
- 5-31 Rossum sand sampler, 121
- 5-32 Influence for various rates of pumping in an aquifer, 124
- 5-33 Steps for model application, 129

- 6-1 Schematic illustrating total static head, 136
- 6-2 Volute-type centrifugal pump, 144
- 6-3 Diffuser-type centrifugal pump, 144
- 6-4 Plunger-type pump, 146
- 6-5 Vertical deep-well turbine pump, 148
- 6-6 Rotary-displacement pump, 150
- 6-7 Rotary-gear pump, 151
- 6-8 Airlift pump, 152
- 6-9 Jet-type deep-well pump, 153

- 7-1 Operating problems resulting from a drop in the water table, 165
- 7-2 Lakos sand separator, 169
- 7-3 Well efficiency monitoring, Catamount well field, well No. 54, 176
- 7-4 Example of well performance history, 177
- 7-5 Example of corroded column pipe, 180
- 7-6 Venice RO well construction after rehabilitation, 182

- 8-1 Flow of contamination from a ponded surface source into an aquifer, 204

- 9-1 Natural draft aeration system, 208
- 9-2 Packed-tower aeration, 209
- 9-3 Chlorine cylinders, 210
- 9-4 Advanced oxidation process—hydrogen peroxide with UV light are typical processes, 211
- 9-5 UV light system, 212
- 9-6 Typical silo for dry lime, 213
- 9-7 Slaker system, 214
- 9-8 Mixed with the raw water in some form of lime softening unit, 214
- 9-9 Ion exchange system, 215
- 9-10 Granular filtration, 216
- 9-11 Pressure filters, 216
- 9-12 Example of filter being backwashed, 217
- 9-13 Typical membrane skids, 224
- 9-14 How membranes work, 224

- 10-1 Well design, 228
- 10-2 Well drilling permit, 229
- 10-3 Well completion report, 231
- 10-4 Well summary information, 232
- 10-5 Pump data hydraulic data sheet, 233
- 10-6 Pump data, turbine 60 Hz 234
- 10-7 Monthly pumping report, 235
- 10-8 Monthly operations report, 236

- 11-1 ASR conceptual diagram for brackish water aquifers, 242
- 11-2 Collier County, Fla., ASR project graph showing recovery efficiency improvement for each succeeding cycle, 243
- 11-3 Schematic of Peace River ASR system, 244
- 11-4 Cross section of the ASR system, 244
- 11-5 Historical operation of the ASR wells, 245
- 11-6 Cumulative volume in storage, 246
- 11-7 Depletion of storage and the TDS of water, 246

GROUNDWATER

- 11-8 Results of a recent extended recovery period, 247
- 11-9 Biscayne Aquifer reclamation water movement after injection, 249
- 11-10 Biscayne Aquifer reclamation buoyancy movement after injection, 249
- 11-11 Biscayne Aquifer reclamation injection well location, 249
- 11-12 Biscayne Aquifer reclamation water movement after injection, 250
- 11-13 Schematic of treatment process, 251
- 11-14 Location of the WRP, 251
- 11-15 Aquifer recharge, 253
- 11-16 Aquifer recharge via flooding, 253
- 11-17 Aquifer reclamation to prevent upconing, 254

Tables

- 4-1 Selected values of porosity, specific yield, and specific retention, 54
- 4-2 Approximate height of capillary rise, h_c , in granular materials, 60
- 4-3 Drawdown test data for observation wells, 71

- 5-1 Summary of well types and notes, 95
- 5-2 USGS grain-size classification, 97
- 5-3 Water-well casing materials, 99
- 5-4 Standard well-casing sizes for wells, 100
- 5-5 Minimum thickness for steel well casing—single casing, 101
- 5-6 Minimum thickness for two-ply steel well casing, 102
- 5-7 Plumbness and alignment test data sheet, 114
- 5-8 Allowable interference drawdowns for various pumping rates, 125

- 6-1 Velocity-head data, 137
- 6-2 Friction loss for water in ft per 100 ft (Schedule 40 Steel Pipe), 138
- 6-3 Equivalent length of new straight pipe for valves and fittings for turbulent flow only, 142
- 6-4 Maximum practical suction lift, in feet, for single-stage centrifugal pump, 145
- 6-5 Air requirements for airlift pumps, 152
- 6-6 Summary of pump types and applications, 154

- 7-1 Well rehab versus replacement comparison, 176
- 7-2 Timeline for well capacity—well No. 1, 183
- 7-3 Timeline for well capacity—well No. 2 and well No. 3, 183

- 8-1 The principal natural chemical constituents in water, concentrations, and effects of usability, 192
- 8-2 MCLs for a variety of organic and inorganic chemicals, 198
- 8-3 Regulated pesticides detected in groundwater, 201
- 8-4 Summary of pharmaceutically active substance occurrence in wastewater effluent and associated surface waters, 203
- 8-5 Major sources of groundwater contamination, 204

- 11-1 Summary of nutrient and coliform results post RO, UV, and AOP, 255
- 11-2 Summary of BOC, COD, TOC, and organic results post RO, UV, and AOP, 255
- 11-3 Summary of pesticide and pathogen results post RO, UV, and AOP, 255
- 11-4 Summary of metals and nitrogen species results post RO, UV and AOP, 256
- 11-5 Cost comparison of AWS options for Pembroke Pines, 257

This page intentionally blank.

Foreword

This AWWA revision to Manual M21 is the culmination of nearly three years of effort by members of the Groundwater Resources Committee. This edition has been written to provide the reader with a general understanding of the principles involved with ground water, its movement and character, and the subsequent impact these characteristics have on the design, construction, and maintenance of groundwater well systems for water utilities. Among the major changes included in content from prior editions are the incorporation of the well construction standards formerly attached to Standard A100 Water Wells and a discussion in chapters 1 and 3 on sustainability of groundwater supplies in light of competition, lack of regulatory limitations, overdrafting, and climate changes. In addition, groundwater protection, planning, and evaluation efforts have evolved during the past 10 years, which have been updated in chapter 3. Modeling techniques have developed as well, to the point where many consumptive-use projects include a modeling exercise. New uses of groundwater, such as aquifer storage and recovery, and new legal issues with interbasin transfers have evolved as well.

The intention of this fourth edition is to create a document that provides a general overview, without the detailed mathematical analyses that are available in many other groundwater books. This manual will provide operators and engineering staff with an understanding of groundwater principles that will help them to make decisions on design, installation, phasing, and repair needs when problems or the need to expand supplies arise.

SCOPE

Chapter 1 is an overview of the occurrence and behavior of groundwater, including the geology, hydrologic cycle, and aquifer characteristics that define groundwater flow, as well as a discussion of sustainability of groundwater supplies in light of competition and climate changes.

Chapter 2 is an overview of the process to evaluate aquifers and water quality to allow engineers, hydrogeologists, and administrators to make decisions on aquifer use. Aquifer tests to define water availability and quality are also presented.

Chapter 3 is an extension of chapter 2 that covers the areas of groundwater protection and management, similar to source water protection efforts and land use controls.

Chapter 4 demonstrates the use of the standard groundwater equations to evaluate well fields and develop computer modeling. An outline of common modeling software is included.

Chapter 5 outlines the type and construction of wells that can be used for water supplies for utilities. Horizontal wells and riverbank filtration were added to this chapter. The well construction standards (plus in the appendices) that were previously attached to the A100 standard have been incorporated into chapter 5.

Chapter 6 describes the types of pumps used in well applications, maintenance requirements, pump problems, and solutions to those problems.

If wells are constructed as discussed in chapter 5, they should be operated, as defined in **chapter 7**. The problems likely to be encountered, including plugging and fouling problems and their correction, are also discussed. Microbiological fouling is a major topic discussed in detail in this chapter, as it has been found to be a major issue throughout the world, albeit one that is not commonly understood.

Chapter 8 presents issues associated with water quality and contaminant transport resulting from organic, inorganic, and bacteriological pollution; the methods to test and monitor these problems; and treatment methods to maintain the water supply quality and reduce maintenance costs.

Chapter 9 summarizes water treatment issues arising from groundwater sources. The discussion is not meant to be exhaustive of the treatment options available but is instead intended to describe common treatment options of which the operators, engineers, and administrators of water supply agencies should be aware.

Chapter 10 discusses the record keeping used with wells and well fields systems. These records provide utility personnel with insight into the occurrence of problems and long-term trends.

Chapter 11 presents emerging groundwater technologies such as aquifer storage and recovery, artificial recharge, and salinity barriers.

Chapter 12 discusses future trends as groundwater moves away from well drilling to more of a management process.

This manual should help operators and engineers gain enough background on the subject of groundwater to improve their decision making. The manual should provide answers to many questions about complex aquifer systems and improve the operators' and engineers' response to problems. The AWWA Groundwater Resources Committee is hopeful that the new edition will meet the industry needs of the new millennium and will be as useful as the prior editions have been.

Frederick Bloetscher, PhD, PE
Chairman, AWWA Groundwater Resources Committee

Acknowledgments



This manual was developed by the AWWA Groundwater Resources Committee. The membership at the time of approval was as follows:

Frederick Bloetscher (Chair), Florida Atlantic University, Boca Raton, Fla.
D.F. Edson, Talkington Edson Environmental Management, Westborough, Mass.
Frank Getchell, Leggette, Brashears & Graham Inc., Upper Saddle River, N.J.
Jeff Henson, Black and Veatch, Kansas City, Mo.
Steve Hubbs, retired, Louisville, Ky.
H.C. Hunt III, Layne Christensen, Gahanna, Ohio
Vanessa Kelly, United States Environmental Protection Agency, Dallas, Texas
Sharon Long, Univeristy of Wisconsin, Madison, Wis.
Stewart Magenheimer, CDM Smith, Fort Lauderdale, Fla.
Margaret Medellin, AWWA staff, Denver, Colo.
Albert Muniz, Hazen & Sawyer, Boca Raton, Fla.
Susan Roberts, Abeinsa, Chesterfield, Mo.
S.A. Smith, Ground Water Science, Poland, Ohio

This page intentionally blank.

The Occurrence and Behavior of Groundwater

More than half of the people served with public water supplies in the United States and Canada obtain their water supplies from groundwater. Nearly 80 percent of all utilities, and most of the smaller systems, derive their source water from groundwater, but groundwater is not visible from the surface and the understanding of its behavior and occurrence by the public is limited. This chapter is intended to provide a general overview of the following:

- the hydrologic cycle
- general groundwater concepts
- major conditions that impact groundwater
- climate impacts on groundwater
- sustainability of groundwater

Because groundwater and surface water resources are closely related, any event that occurs aboveground can impact an underground water supply, a fact often not understood by the public and some regulatory agencies. As a result, water purveyors that derive their water sources from groundwater need to monitor surface events, such as rainfall, spills, development, and drought to determine the potential impact on their water systems, as discussed throughout this manual. In addition, the sustainability of many groundwater supplies is in question. If these groundwater supplies do not recharge, several things can occur: land subsidence in areas with friable or unconsolidated materials, potential diminishment or loss of a natural resource, and long-term negative impacts on a sustainable

local economy. Reilly et al. (2009) have identified that the overuse of groundwater supplies may be particularly problematic in parts of the western United States and along the eastern seaboard, but this may be symptomatic of the overuse of groundwater in general. Climate impacts on groundwater are addressed in this chapter as well.

HYDROLOGIC CYCLE

Of the total water found on earth, 97.3 percent is saltwater in the oceans. Of the remaining water, over two thirds exists as ice in the polar caps. The rest, or 0.61 percent of all water, is fresh water in lakes, rivers, streams, and groundwater. Seventy-five percent is groundwater. That means that while there is a lot of water out there, getting to a sustainable supply may be of issue.

The constant movement of water above, on, and below the earth's surface is defined as the hydrologic cycle as depicted in Figure 1-1. The hydrologic cycle is the main concept used in the development and management of water supplies. The components of the hydrologic cycle are

- evapotranspiration (ET)
- precipitation
- surface water and runoff
- groundwater

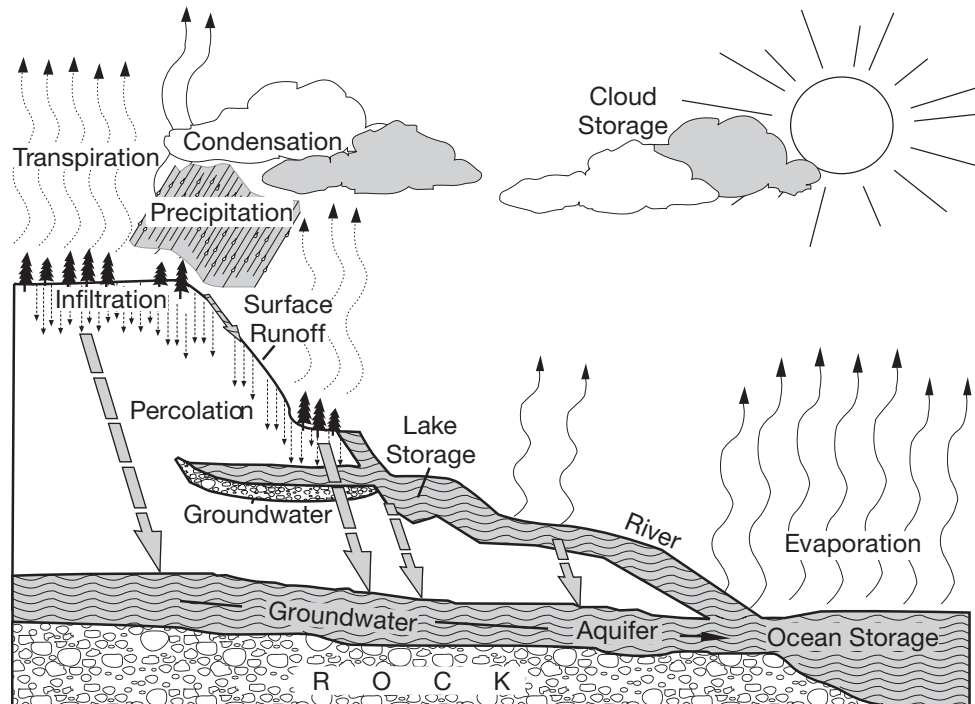

Source: US National Weather Service 1998

Figure 1-1 Hydrologic cycle

Evaporation and Transpiration

Although the hydrologic cycle is continuous and has neither a beginning nor an end, evaporation and transpiration will be discussed first in this manual. These two processes are commonly combined and referred to as *evapotranspiration* (ET). ET is the process of water vapor entering the atmosphere both through water that evaporates from open water bodies and water that transpires from vegetation or other sources. ET rates vary, depending largely on the amount of solar radiation, the latitude of the catchment area, the amount of heat, water surface area, and vegetative cover. Areas close to the equator tend to have higher ET rates. Figure 1-2 is a map of ET rates in the United States (similar mapping may be available for Canada and Mexico). In subtropical areas during the wet season or during summer months in northern latitudes, large bodies of water, including wetlands and estuarine areas, have high evaporation rates. This rising moisture forms clouds that condense and return the water to the land surface or oceans in the form of precipitation. The highest evaporation rates are associated with shallow, open water bodies. Water as much as 4 ft below the surface may be subject to evaporation to some degree.

To grow, plants must continually absorb water through their roots and circulate it up through their leaves. Water vapor evaporates from the plant through transpiration during photosynthesis. For plants that grow in swampy environments, the quantity of water lost is significant. On average, ET during the summer months offsets a good portion of the rainfall. Figure 1-3 shows a comparison of ET rates and rainfall in South Florida. Figure 1-3 shows that the ET rates are normally highest in the summer, which is typical across North America. Subtropical south Florida is different in that rainfall is also highest in the summer offsetting the ET loss. In the rest of North America, the summer ET rate is not offset by extensive rainfall.

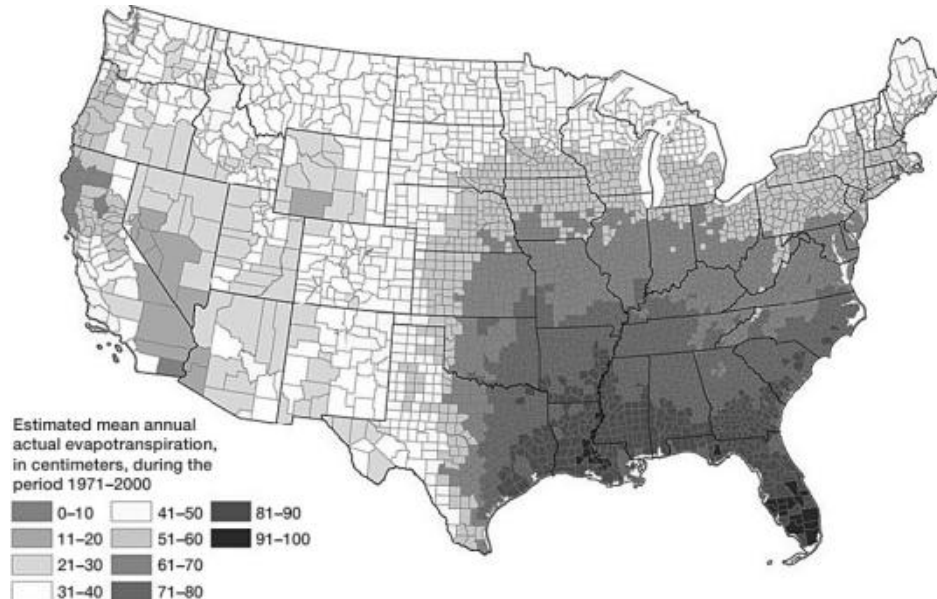

Source: NOAA 2013 <http://summitcountyvoice.com/2013/03/18/usgs-water-study-details-evapotranspiration-rates/>. Courtesy USGS.

Figure 1-2 Evapotranspiration rates

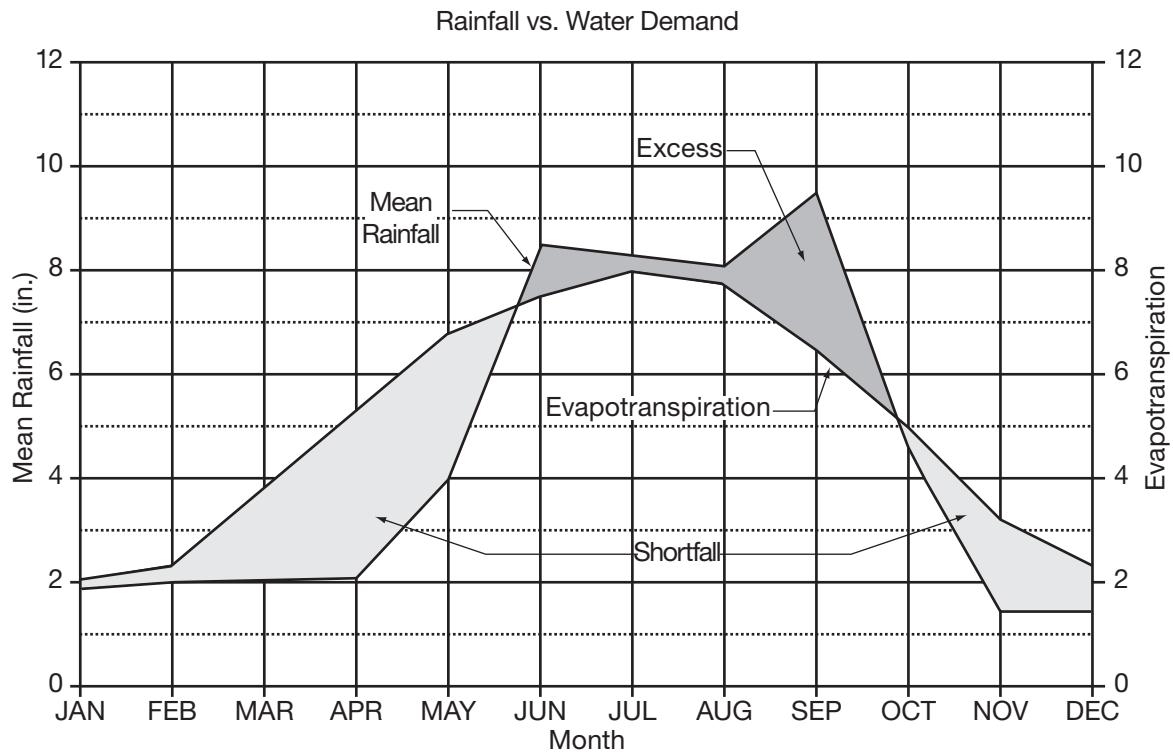

Figure 1-3 A comparison of ET rates and rainfall in South Florida

Precipitation

Precipitation occurs in several forms, including rain, snow, sleet, and hail. Water vapor from ET forms clouds. The intensity of the resulting rainfall is a major area of hydrologic study as it seems rainfall intensity is increasing with time. Rainfall intensity can vary up to 5 in. per hour in subtropical areas but is commonly 2–3 in. per hour across North America. Figure 1-4 shows intensities that occur in the continental United States (similar mapping may be available for Canada and Mexico). Rainfall intensity is relevant because the rain wets vegetation and other surfaces, then infiltrates the ground. Infiltration rates vary widely, depending on land use, development, the character and moisture content of the soil, and the intensity and duration of the precipitation event. Infiltration rates can vary from as much as 1 in./hr or 25 mm/hr in mature forests on sandy soils, to almost nothing in clay soils and paved areas. If and when the rate of precipitation exceeds the rate of infiltration, overland flow or runoff occurs. Figure 1-5 shows average annual precipitation in the United States. The data can be logically extended into Canada and Mexico along the borders.

Surface Water

Precipitation that runs off the land, reaching streams, rivers, or lakes, or groundwater that discharges into these water bodies is surface water. Surface water bodies that mix with saltwater bodies along the coast are called *estuaries*; for example, where a river meets the ocean in a delta. Surface water flow is controlled by topography because water on the surface flows downward by gravity, eventually reaching the oceans.

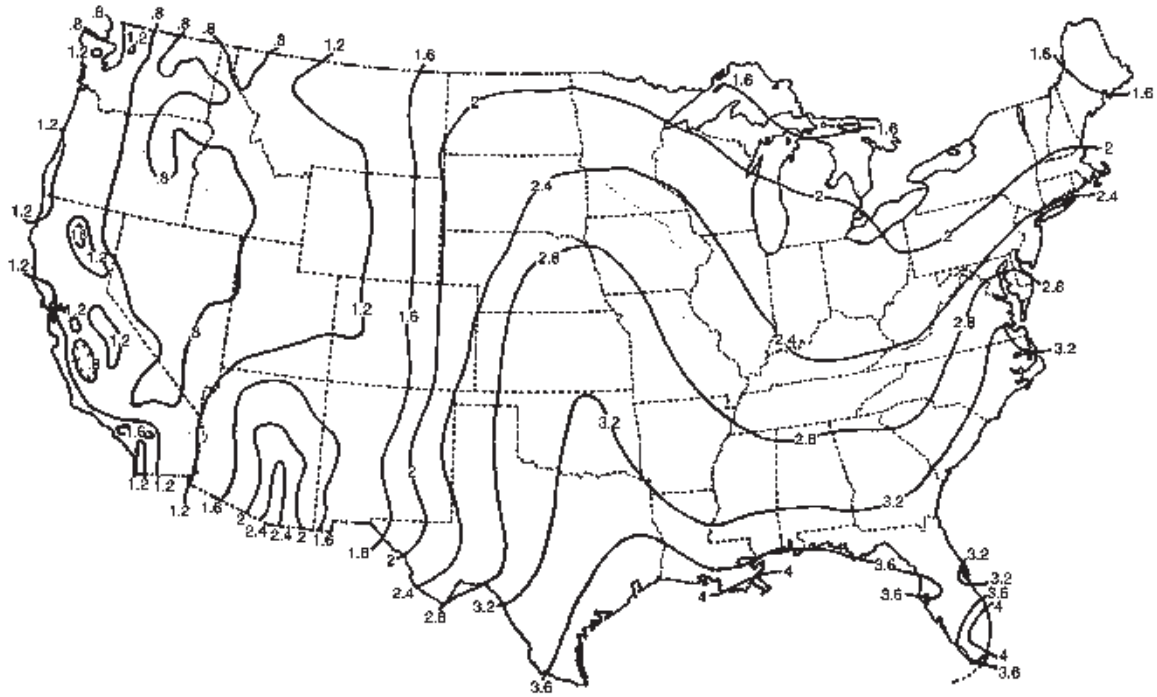

Source: US National Weather Service 1998

Figure 1-4 One-hour rainfall (inches) to be expected once on average in 25 years

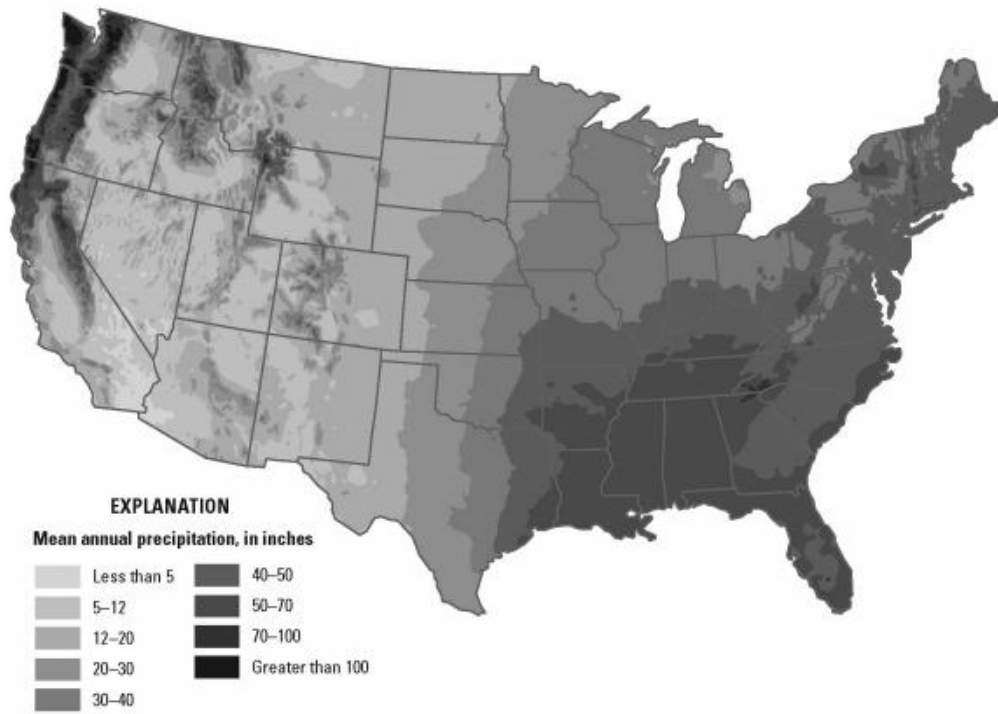

Source: NOAA 2002

Figure 1-5 Average annual precipitation (inches) in the United States (1961-1990)

GROUNDWATER CONCEPTS

The quantity and quality of groundwater depend on factors such as depth, rainfall, and geology. For example, the flow velocity and flow direction of groundwater depend on the permeability of sediment and rock layers, and the relative pressure of groundwater. A one-mile-square area 20-ft thick with a 25 percent porosity would hold one billion gallons of water. However, due to variable rates of groundwater flow and the impacts of withdrawals, such an area may not hold the one billion gallons at all times. The main concepts and factors related to groundwater include infiltration and recharge, unsaturated and saturated zones, and aquifers and confining beds. These are discussed in the following paragraphs.

Infiltration and Recharge

Precipitation that percolates downward through porous surface soils is the primary source of water for groundwater. Surface areas having this downward flow are called *recharge areas*. The characteristics of soil depend on the soil forming parent material, the climate, soil chemistry, the types of organisms in and on the soil, the topography of the land, and the amount of time these factors have acted on the material. Because vegetative types differ in their nutrient requirements and in their ability to live in water-saturated or saline areas, soil types also play a role in determining plant distribution.

Soil has the capacity to absorb some moisture initially, a factor called *initial infiltration*. Initial infiltration replaces moisture in the root or plant zones, where the roots for most vegetation exist. Because of the variable permeability and transmissivity of different soils, the rate of groundwater recharge from precipitation will vary. Recharge areas for deeper groundwater can be located far from the point of use. For an aquifer to have fresh water, there must be a source of recharge, some degree of flow (albeit slow), and a discharge area (to cause the flow). Otherwise, if there were no recharge or movement, the aquifer would become brackish through dissolution of the minerals in the rock.

Unsaturated and Saturated Zones

After precipitation has infiltrated the soil, it will travel down through two zones. The unsaturated zone occurs immediately below the land surface in most areas where pore space contains water and air. The unsaturated zone is almost invariably underlain by a zone in which all interconnected openings are full of water. This zone is referred to as the saturated zone and is illustrated in Figure 1-6.

Water in the saturated zone, technically called *groundwater*, is contained in interconnected pores located either below the water table in an unconfined aquifer or in a confined aquifer. Recharge of the saturated zone occurs by percolation of water from the land surface through the unsaturated zone. The unsaturated zone is, therefore, of great importance to groundwater hydrology. This zone may be divided usefully into three parts: the soil zone, the intermediate zone, and the upper part of the capillary fringe.

Soil zone. The soil zone typically extends from the land surface to a maximum depth of 3 to 5 ft (1 to 1.6 m). The soil zone supports plant growth, and it is crisscrossed by living roots, voids left by decayed roots of earlier vegetation, and animal and worm burrows. The porosity and permeability of the material in this zone tend to be higher than the porosity and permeability of the ground beneath it.

Intermediate zone. Below the soil zone is the intermediate zone, which differs in thickness from place to place, depending on the thickness of the soil zone and the depth to the capillary fringe. The intermediate zone is less porous than the soil zone because few roots or burrows penetrate it.

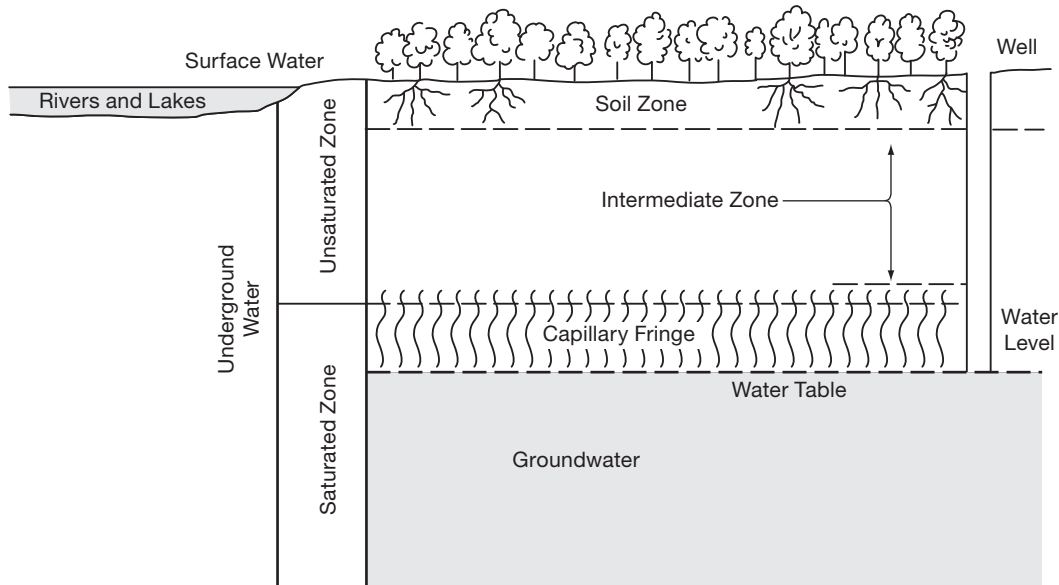

Figure 1-6 Water movement below the earth's surface

Capillary fringe. The capillary fringe is the subzone between the unsaturated and saturated zones. The capillary fringe occurs when a film of water clings to the surface of rock particles and rises in small-diameter pores against the pull of gravity. Water in the capillary fringe and in the overlying part of the unsaturated zone is under a negative hydraulic pressure, that is, less than atmospheric (barometric) pressure. The water table is the water level in the saturated zone at which the hydraulic pressure is equal to atmospheric pressure. Below the water table, the hydraulic pressure increases with increasing depth.

Aquifers and Confining Beds

Below the unsaturated soil zone, all rocks (including unconsolidated sediments) under the earth's surface can be classified either as aquifers, semi-confining units, or as confining units. An aquifer is rock that will yield water in a usable quantity to a well or spring. Some of the groundwater has been stored in aquifers for hundreds or even thousands of years. The older the rock, the more constituents the water might contain because of added contact time to dissolve the formation, although flow velocity also increases dissolution. A confining unit is rock having very low hydraulic conductivity that restricts the movement of groundwater either into or out of adjacent rock formations as shown in Figure 1-7.

Groundwater occurs in aquifers under two different conditions: *unconfined* and *confined*. Near the land surface, water may only partly fill an exposed aquifer. The upper surface of the saturated zone is free to rise and decline in direct relation to recharge by precipitation. The water in this type of aquifer is *unconfined*, and the aquifer is considered to be an unconfined or water-table aquifer. Wells that pump water from unconfined aquifers are water-table wells. The water level in these wells generally indicates the position of the water table in the surrounding aquifer. With unconfined aquifers, rainfall recharges them easily, so they are considered sustainable supplies.

Although clay layers (and some rock formations such as shale) have high porosity, water cannot easily flow through them. As such, they have *low hydraulic conductivity* and can be functionally impermeable. Hydraulic conductivity (K) is the ability of water to flow through a porous media. Clay or shale has very low K , which is why it is typically considered a *confining* unit as opposed to an aquifer. Water will tend to flow preferentially where

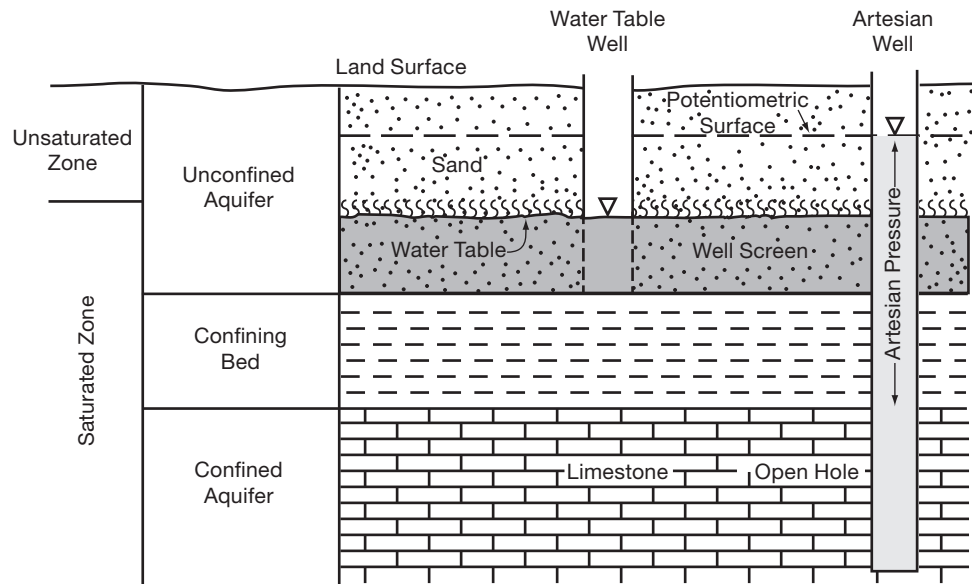

Figure 1-7 Geologic configuration of aquifers and confining beds

the resistance is lowest, and therefore clay is rarely the preferred route. Often, a clay or shale layer will intercept or overlay portions of an aquifer, making that aquifer a confined aquifer.

Where water completely fills an aquifer that is overlain by a confining bed, the water in the aquifer is said to be confined. Such aquifers are referred to as *confined aquifers*. Wells drilled into confined aquifers are referred to as *artesian wells* if the pressure of the water in the confined aquifer is above the top of the formation. If the water level in an artesian well stands above the land surface, the well is a *flowing artesian well*.

Under natural conditions, groundwater moves downgradient until it reaches the land surface at a spring or through a seep along the side or bottom of a stream channel or estuary, or, in deeper aquifers, i.e., the oceans. Groundwater in the shallowest part of the saturated zone moves from interstream areas toward streams or the coast. In many areas, the direction of groundwater movement can be derived from observations of land topography when the land slopes toward water bodies. Thus, the water table usually replicates the land surface as shown in Figure 1-8.

When a well (artesian or not) is pumped, the level of the aquifer falls as the water immediately surrounding the well is drawn through the pumping well. The falling level is called *drawdown*, and the three-dimensional cross-section is called the *cone of depression*. If the aquifer transmits water easily (i.e., has high transmissivity, which is a hydraulic property found by multiplying the hydraulic conductivity (K) by the thickness of the aquifer), the drawdown is slight and the cone of depression is flat and widespread as depicted in Figure 1-9. If the aquifer has low transmissivity, drawdown is significant and the cone of depression is steep. Higher flow rates result in steeper drawdown and, consequently, larger cones of depression. The cone of depression is also affected by the level of water within the aquifer. When investigating potential groundwater sources, engineers and hydrogeologists typically look for limestone, sandstone, and alluvial formations, which tend to have high transmissivity. The engineers and hydrogeologists avoid clay, shale, and similar zones, which have low transmissivity.

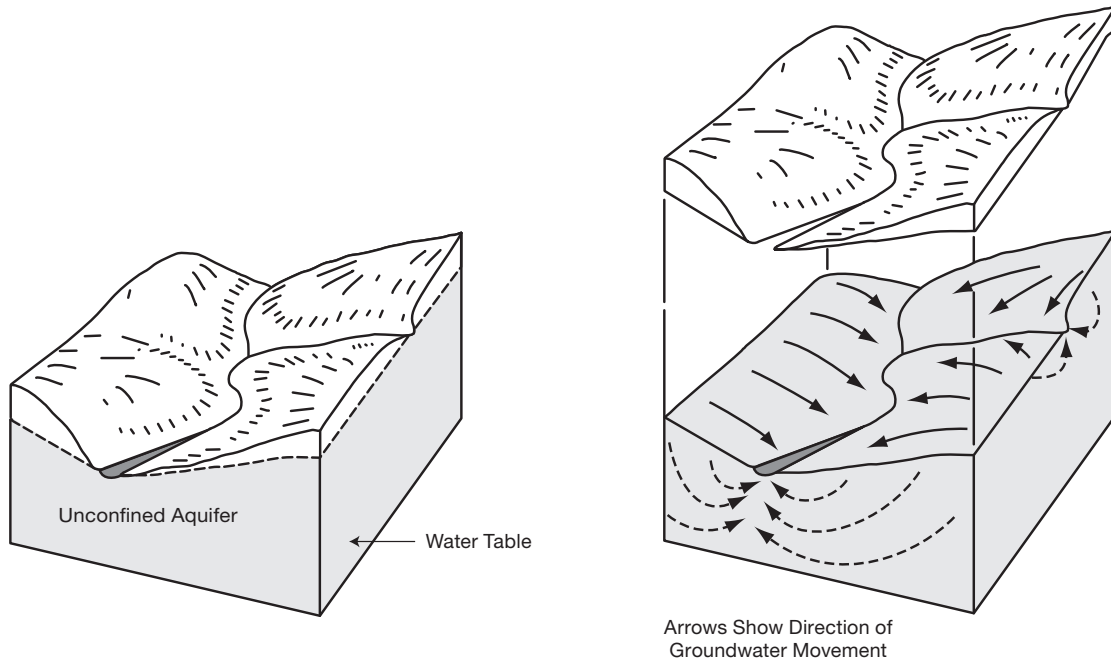

Figure 1-8 Groundwater movement as it relates to topography

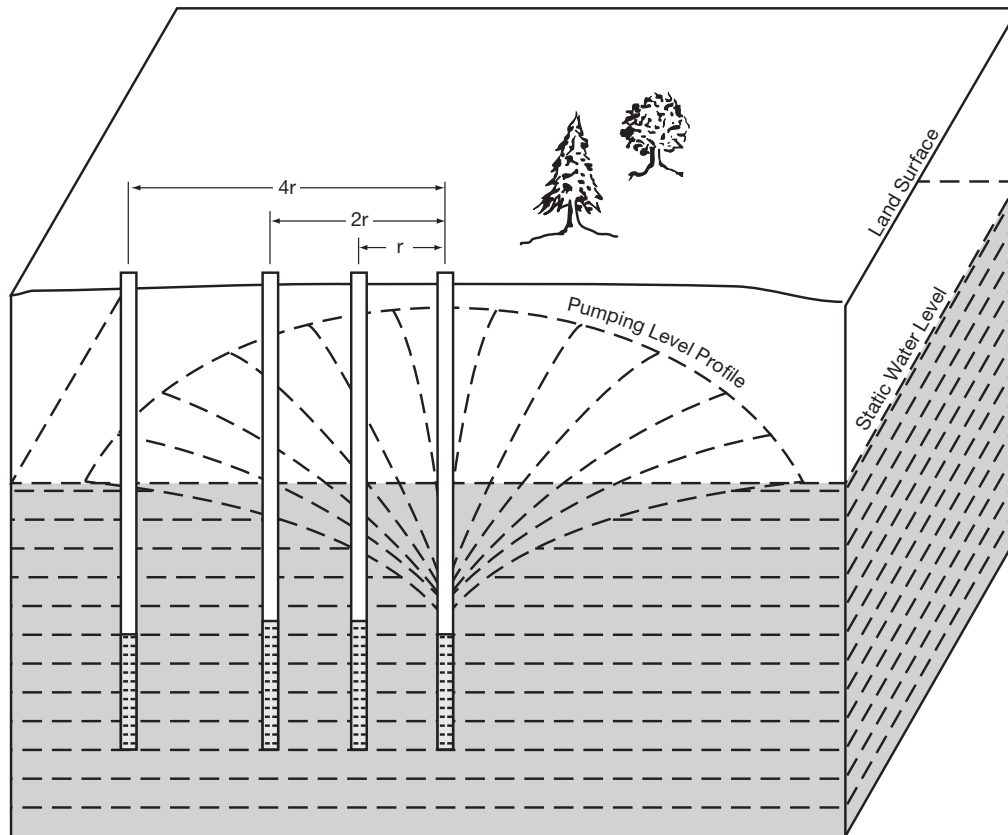

Figure 1-9 Development of a cone of depression

Formations in contact with groundwater affect water quality. Before groundwater is intercepted by a well, it is in lengthy contact with formation materials, and only moves slowly toward a well even when pumped. Groundwater also starts as recharged water that flows through a variety of formation materials before reaching an aquifer. Therefore, the types of rock strata that underlie the area have significant bearing on the quality and quantity of groundwater available and the ability of the rocks to store water.

MAJOR CONDITIONS THAT IMPACT GROUNDWATER

Along with an understanding of general groundwater concepts, it is important to recognize different conditions that impact groundwater. Two major conditions include subsidence and climate.

Land Surface Subsidence

A significant consequence of groundwater development from unconsolidated or highly friable rock formations can be downward movement of the land surface, called *subsidence*. Subsidence can occur when the groundwater, which exerts pressure on the adjacent soil and rock, is removed, relieving the pressure. The formation then collapses, causing the surface topography to be altered. Recharging an aquifer that has collapsed will not restore the land surface to its prior state because the collapsed formation has less void space (which is why the collapse occurred). The collapse is caused by the reorientation of aquifer grains as a result of the loss of pore pressure exerted by the water in the aquifer. Development of groundwater needs to include consideration of possible land-surface subsidence, especially from overdevelopment. Figure 1-10 shows areas that US Geological Survey has identified as having significant land subsidence issues. In some areas, clays such as montmorillonite may exist beneath the surface, causing significant problems for water purveyors. These clays can be 46 to 55 percent porous, with their structure supported by the internal pore pressure of water. As pore pressure is reduced when water levels decline, most of the compression occurs in the clay units, causing land subsidence.

Estimating Subsidence

The magnitude of subsidence in areas subject to flooding either by tidal inundation or alteration of surface drainage should be estimated, especially in aquifers with high clay or sand content, or where prior subsidence has been noted. Subsidence along faults that could lead to structural damage must be estimated.

The most readily available of the necessary data is the amount of compressible material in the subsurface. Such data may be obtained from evaluation of logs of test wells. Data on water-level changes can be used to make estimates of pressure change (stress change) at various depths for various time intervals. Where subsidence has been well documented, subsidence data may be coupled with the amount of compressible material to determine compressibility. Unfortunately, the information needed is not available in sufficient detail in most areas.

Data on the degree of compressibility of the subsurface material can be used to predict subsidence, but the data are rarely readily available. Laboratory values of compressibility determined from tests of cores have been used with limited success as a result of the expense of obtaining undisturbed cores, and the difficulty in obtaining representative cores preclude their use for regional appraisal.



Source: USGS Circular 1182

Figure 1-10 Areas where land surface subsidence is an issue

Climate Impacts on Groundwater

In a geologic timescale, the earth's climate undergoes constant changes (Bloetscher 2008). Massive continental glaciers extended as far south as the 40th parallel in North America and Eurasia. There were several advances throughout the Pleistocene era, starting more than 600,000 years before present (BP) and extending to as recently as 10,000 years BP. These glacial advances and retreats profoundly altered the landscape, covering northern Europe and the northern United States with deep till and outwash soils, and developed massive, productive sand-and-gravel aquifers. Less than 5,000 years ago, the Sahara desert was a thriving, water soaked area that supported significant human population, but as the climate changed, it became more arid. It should also be appreciated that much groundwater available in the western United States is fossil water from the Pleistocene period. Brief interludes of warmer and cooler periods occurred during the Dark and Middle Ages (400–1300 AD).

The conclusions of the 2007 Intergovernmental Panel on Climate Change (IPCC) report noted that water resources would be one of the areas most affected by climate change. The most relevant impact to water resources and groundwater are (IPCC 2007):

- Projected warming in the twenty-first century shows geographical patterns similar to those observed over the last few decades, which may increase ET, and reduce the potential for infiltration to replenish groundwater.
- Warming is expected to be greatest over land and at the highest northern latitudes, and least over the southern oceans and parts of the north Atlantic Ocean.
- Snow cover is projected to contract.
- Widespread increases in thaw depth are projected over most permafrost regions.
- The more optimistic globally averaged rises in sea level at the end of the twenty-first century are between 0.18–0.38 m, but an extreme scenario gives a rise up to 5 m. Sea level rise will inundate low-lying areas and increase saltwater intrusion along coastlines.
- Temperature extremes, heat waves, and heavy precipitation events will continue to become more frequent.

- Increases in the amount of precipitation are very likely at high latitudes, but not as snow pack, whereas rainfall decreases are likely in most subtropical land regions.

It should be noted that there is significant uncertainty in the models used to prepare the IPCC reports to predict the actual intensity, spatial and time variability of rainfall and temperature for a given region in part because the models can only be calibrated against a very short period of time, and that as time has proceeded, the predicted changes have moderated to some degree to comport with observed changes. In any case, the main concern raised by global warming is that climatic variations alter the hydrologic cycle, and that the current data indicated that hydrological cycle is already being impacted: more intense rainfall, less recharge, less snowpack, higher seas, all of which result in less recharge (Dragoni 1998; Buffoni et al. 2002; Labat et al. 2004; Huntington 2006; IPCC 2007; Dragoni and Sukhija 2008).

ACHIEVING SUSTAINABILITY

Climate impacts on the hydrological cycle predicate a necessary discussion of sustainable use of water supplies. The key component in planning the use of water supplies is to determine how the hydrologic cycle provides water to the service area (e.g., recharge basin), in what quantities, and with what reliability. The reliability is a risk issue—is the precipitation consistent or are there significant fluctuations that disrupt ongoing basin development (Molak 2007)? It is widely recognized that

$$\text{Withdrawals} = \text{Consumption} + \text{Returns (to hydrologic cycle)}$$

However, the concept is not that simple, and buy-in to the concept of “sustainable water” depends on the profession or perspective of the person defining it. From a hydrologic perspective, the term *sustainable yield* is the amount of water that can be withdrawn from a source at rates that are less than their recharge potential and that do not deteriorate the source or basin. While many water providers attempt to develop sustainably, others have not. Within regionally sustainable situations, unsustainable pumping can occur locally. For example, much of the groundwater in the western United States appears to be unsustainable in the long term because of limited rainfall (Reilly et al. 2009).

Typically, there are a variety of uses competing for water resources, and each basin has unique characteristics (Bloetscher and Muniz 2008):

- Agriculture
- Ecosystems
- Urban demands
- Industrial demands
- Cooling water for power generation

From a practical perspective, sustainable development generally means addressing environmental, economic, and social concerns. Researchers can define a comprehensible concept of sustainability, but practitioners emphasize feasibility and limitation to sustainability of the ecosystem (Starkl and Brunner 2004). Water quantity and quality issues have significant fiscal impact on the potential users in the basin, and there are unrealized costs and benefits that are often ignored in the current water management framework (Bloetscher and Muniz 2008).

A sustainable world is not a rigid one, where population or productivity is constant; sustainability must adapt to constant change. The concept of sustainability requires rules, laws, and social constraints that are recognized and adhered to by all (Meadows

and Randers 2005). At the present time, the desire to grow and develop economically is outweighing the rule-making process. These issues will be discussed in more depth in chapter 3.

REFERENCES

- Beck, M.B. 2005. "Vulnerability of Water Quality in Intensively Developing Urban Watersheds," *Environmental Modeling and Software*, Vol. 20, pp. 381–400.
- Bloetscher, Frederick. 2008. "The Potential Impact of Climate Change on Groundwater Recharge," *GWPC Annual Forum Proceedings*. Groundwater Protection Council, Oklahoma City, Okla.
- Bloetscher, Frederick, and A. Muniz. 2008. Water Supply in South Florida—The New Limitations. *Sustainable Water Sources (Reno) Conference Proceedings*. Denver, Colo.: American Water Works Association.
- Buffoni, L.B. 2002. Variazioni Climate Change and Groundwater: A Short Review 7. *Italia Negli Ultimi 130 Anni. Bollettino Geofisico Anno XXIII*.
- Di Matteo, L., and W. Dragoni. 2006. Climate change and water resources in limestone and mountain areas: the case of Firenzuola Lake (Umbria, Italy). *Proceedings of the 8th Conference on Limestone Hydrogeology, Neuchatel, Switzerland, 21–23 September 2006*. Presses Universitaires de Franche-Comte, France, 83–88.
- Dragoni, W. 1998. Some considerations on climatic changes, water resources and water needs in the Italian region south of the 438N. In A.S. Issar, *Water, Environment and Society in Times of Climatic Change*. pp. 241–271. Alphen aan den Rijn, the Netherlands: Wolters Kluwer.
- Dragoni, W.A., and B.S. Sukhija. 2008. Climate change and groundwater: a short review. *Geological Society, London, Special Publications*. 288: 1–12.
- Goudie, A. 1994. *The Human Impact on the Environment*. Cambridge, Mass.: The MIT Press.
- Hapgood, C.H. 1999. *Path of the Pole*, 2nd Ed. , Kempton, Ill.: Adventures Unlimited Press.
- Hershfield, D.M. 1963. Rainfall Frequency Atlas of the United States for Durations from 30 Minutes to 24 Hours and Return Periods from 1 to 100 Years. Technical Paper 40. Washington, D.C.: National Oceanic and Atmospheric Administration.
- Huggett, R.J. 1991. *Climate, Earth Processes and Earth History*. Berlin, Germany: Springer-Verlag.
- Huntington, T.G. 2006. Evidence for intensification of the global water cycle: Review and synthesis. *Jour. of Hydrology*. 319:83–95.
- Intergovernmental Panel on Climate Change (IPCC). 2007. *Climate Change 2007: The Physical Science Basis*. Geneva, Switzerland: IPCC.
- Issar, A.S. 2005. *Mitigating the greenhouse effect by sequestering carbon by woods planted in dry-zones, utilizing wasted water resources*. Presented at World Water Week in Stockholm, Aug. 21–27, 2005. Workshop 2 – Coping with Climate Variability, Climate Change and Water-Related Hazards.
- Labat, D.G. 2004. Evidence for global runoff increase related to climate warming. *Advances in Water Resources*. 27: 631–642.
- Lamy, F., H.W. Arz, G.C. Bond, A. Bahr, and J. Patzold. 2006. Multicentennial-scale hydrological changes in the Black Sea and northern Red Sea during the Holocene and the Arctic/North Atlantic Oscillation. *Paleoceanography*, 21, PA1008, 11.
- Marshall, C.H., R.A. Pielke, L.T. Steyaert, and A.W. Debra. 2004. The impact of anthropogenic land—Cover change on the Florida Peninsula sea breezes and warm season sensible weather. *Mon. Wea. Rev.* 132: 28–52.
- Meadows, D., and J. Randers. 2005. *Limits to Growth: The 30-Year Update*. White River Junction, Vt.: Chelsea Green Publishing Co.
- Molak, V. 1997. *Fundamentals of Risk Analysis and Management*. Boca Raton, Fla.: Lewis Publishers.
- National Research Council (NRC). *Assigning Economic Value to Natural Resources*. Washington, D.C.: National Academy Press.
- Pearce, D., and D. Moran. 1994. *The Economic Value of Diversity*. London, UK: IUCN, Earthscan Publications Ltd.
- Popp, J., D. Hoag, and D.E. Hyatt. 2001. Sustainability Indices with Multiple Objectives. *Ecological Indicators*, Vol. 1, pp. 37–47.

- Reilly, T.E., K.F. Dennehy, W.M. Alley, and W.L. Cunningham. 2009. Ground-Water Availability in the United States, *USGS Circular 1323*. Reston, Va.: USGS.
- Singer, F.E. (ed.). 2008. *Nature, Not Human Activity, Rules Climate Change, Summary for Policy Makers, the Nongovernmental International Panel on Climate Changes*. Chicago, Ill.: The Heartland Institute.
- Starkl, M., and N. Brunner. 2004. Feasibility versus Sustainability in Urban Water Management. *Jour. of Environmental Management*, Vol. 71, pp. 245–260.
- Strzepek, K.M. and D.N. Yates. 1997. Climate Change impacts on the hydrologic resources of Europe: a simplified continental scale analysis. *Climatic Change*, 36:79–92.
- Yang, M., T. Yao, H. Wang and X. Gou. 2006. Climatic oscillations over the past 120 k years recorded in the Guliya ice core, China. *Quaternary International*, 154–155, 11–18.

Evaluation of Groundwater Conditions

Three steps are used in identifying potential groundwater sources for a public water supply. The first is identifying regions having low pollution potential, high recharge capability, and a favorable location to the utility and its customers. The second step is performing field investigations to confirm site-specific characteristics of the aquifer system to determine how much water is potentially available. Care should be taken with confined aquifers where water withdrawal capability is consistently overestimated. The third is dealing with land use and source water protection issues (which are discussed in chapter 3).

The evaluation of regional groundwater conditions and the potential for resource development should be based on the following factors:

- The quantity and quality of water required
- The availability of water resources within the vicinity of the regional demand, including the sustainable yield of the potential source aquifers
- The cost to develop the water supply for the region
- The nature and density of existing or likely future pollution sources within the recharge area of an aquifer, and the effectiveness of regulatory controls on these sources
- The amount of previous groundwater development and availability of hydrogeologic or groundwater pollution investigations
- Long-term land uses affecting quality and quantity of groundwater recharge
- Conveyance costs and treatment required for specific development projects

Additional factors include the following:

- Legal issues, such as water rights, adjudications, water transfers, and conjunctive use commitments
- Financial issues, such as taxation on pumping to pay for groundwater replenishment
- Environmental concerns, such as for endangered species and critical habitat
- Resource management issues, including potential for recycling and conservation

SUITABLE GROUNDWATER SUPPLIES

In the past, groundwater was typically assumed not to be affected by surface activities. These perceptions of purity have created expectations of consistently reliable groundwater sources. Unfortunately, groundwater sources cannot be assumed to be safe all the time. In 1969, a national study of 1,000 potable water systems found that more than a quarter of the wells associated with those systems were contaminated by pollutants ranging from minerals to solvents and other hydrocarbons, sometimes to the point of making groundwater supplies unsuitable for drinking water. These problems led directly to the passage of the Safe Drinking Water Act (SDWA).

Water Quality Considerations

Traditionally, the materials that have affected the value of a groundwater supply have included naturally occurring minerals, such as dissolved inorganic salts. High quantities of minerals results in low-quality water. A significant relationship exists between mineral quality and depth and age of groundwater: the mineral quality of groundwater generally declines with depth. Groundwater quality in many sedimentary basins, where the older and deeper sediments were deposited by oceans, can change very abruptly in mineral content. Poor-quality water can be drawn upward after production begins (*upconing*), even if a production well does not penetrate a saline zone. Similarly, operation of coastal production wells can induce saltwater intrusion into freshwater aquifers. Therefore, drilling deeper is not the solution to the problem of severe mineralization.

Today, many forms of contamination exist. Synthetic and other organic compounds, plus refined minerals, high dissolved solids content and heavy metals, must be considered when evaluating the development potential of a groundwater resource. Microbiological substances, especially in membrane treatment applications, are increasingly a concern. In many cases, construction, maintenance, and operation of facilities to remove these substances is more costly than finding a new water source.

Pollution control. The types of waste generated within local areas, methods of handling and disposing of the waste, the likelihood of accidental or unreported spills and leaks, and the hydrogeology of intervening materials are important when evaluating groundwater quality. All groundwater supplies should be analyzed for potential pollution contamination. No groundwater is free from micro-organisms.

Land Use

Agricultural use of land can affect groundwater quality because of pesticide, herbicide, fertilizer, and animal waste in the runoff. Residential land uses with septic tanks may pollute groundwater with household chemicals, microbiological contaminants, salts, and nitrates. Historical land use practices must be reviewed before any site is selected for installation of a well. Potential development and impacts of that development should also be considered so that future land use does not degrade the water that flows off the land in the vicinity of the well. The existence of private property rights laws that restrict concurrent uses of land

based on assumed or actual devaluation of the property (i.e., the well field may degrade the property to the extent that the property loses value and is in essence a taking) may frustrate utility efforts to protect water sources without significant cost for land acquisition. Testing for contaminants throughout a proposed well field is required by federal, state, and local regulations. Pollution source areas, especially capture zones and those that are currently upgradient of the proposed water supply site, are of utmost concern.

As land uses change, an aquifer with good quality at the time of development may deteriorate. Consequently, water resource professionals must obtain and maintain a good understanding of urban and industrial growth and zoning of the area associated with the groundwater supply. Today, simulation models can depict the long-term effects of a proposed water-well development and provide documentation of any land-use changes that may affect the local hydrology. Examples are industrial development displacing irrigated agriculture or paving from urbanization that reduces recharge. This modeling can take the form of analytical solutions for simple cases or numerical computer codes for more complex cases where a high degree of accuracy is needed. Medium and large utilities should all have working computer models of the groundwater in the aquifer of the well field (see chapter 5). For example, USGS's MODFLOW is currently the basis for most commercial models. MODFLOW may be sufficient for local applications, although more extensive modeling, and significantly more data, may be needed if surface interfaces and competing users are located in a given basin. The basin approach, even with groundwater, appears to be more appropriate than simple local modeling.

Because of a lack of certainty about flow patterns and possible changes in flow patterns, judgment is required for all methods of groundwater modeling. In addition, flow of discharged material in the unsaturated zone is not governed by groundwater gradients, and dense nonaqueous phase liquid and light nonaqueous phase liquid contaminants can move contrary to prevailing groundwater flow. Groundwater development should be upgradient or downgradient at an appropriate distance from potential threats to the water quality. Testing for pollutants at greater frequency may be appropriate, and establishing early-warning monitoring wells at various depths may be required to maintain groundwater quality.

Published Reports

Utility-commissioned reports from existing public suppliers, reports from local drillers, and published reports from government agencies such as the USGS are good sources to use when analyzing groundwater conditions. While drillers' logs and well-completion details can be confidential, a utility may be able to negotiate access to these records for specific projects.

Published reports on groundwater resources are available covering various geographic regions, including major aquifers, drainage and recharge basins, and state, county, and local regions. For studies within the United States, the Summary Appraisals of the Nation's *Ground-Water Resources* (USGS 1978–1982) is a good resource. An individual report covering the region of interest can be obtained separately, or a compilation of all 20 reports is offered by Todd (1984). These reports provide a summary of the quantity and quality of available groundwater. By examining the supporting references that are cited for specific localities, data can be layered to provide a more comprehensive understanding of the aquifer.

Valuable information regarding contamination sources may be obtained from state and federal programs that administer hazardous waste or effluent programs. These programs monitor groundwater quality as preliminary steps before granting operating permits for groundwater wells. A local, licensed hydrogeologist or engineer will likely have a significant amount of information on water quality parameters and drilling conditions.

Caution should be used in any investigation because even fairly site-specific reports are necessarily general in nature, and many local details may be omitted. Local conditions may differ from the regional average, and if good prospects for resource development are rare, areas that do not at first appear attractive in the general reports may have to be explored. Also, water quality can change with time (especially in the shallower groundwater zones), and site-specific variations will not appear in the published literature. Therefore, some exploratory work will have to be done to provide needed details regarding water quality.

Existing Water Rights

The development of new well fields should be shown to not infringe on existing water rights or competing water uses. The water developer should be able to demonstrate sustainable yield and also show that the side effects of pumping, such as land subsidence or saltwater intrusion, or interference with competing water or competing land users, would be negligible. Often this can be accomplished via computer modeling by using a program such as USGS's MODFLOW program. These models also can be used to demonstrate to regulatory agencies that proposed drawdowns will not be detrimental to the environment or adjacent users, or exceed the drawdowns set by regulation. Aside from the investigation of the hydrogeology, water quality should also be considered. Computer programs are also available for use in conjunction with water quality analyses.

Changes Affecting Evaluation

Changes in economics may influence local officials to develop more groundwater resources or the public to demand higher quality water. These changes may be at odds with the utility provider's aquifer protection programs or make public relations efforts difficult. Consequently, reliable measurements must be obtained when evaluating any groundwater system.

Deterioration of water quantity and quality can have grave consequences for those dependent on the water resource in the form of higher treatment costs or abandonment of the well field. However, changes other than those measured in the field can often be of great concern. Perceived changes may be caused by the availability of improved analytical methodologies (which detect levels of compounds not previously measurable or of new chemicals); regulatory priority shifts toward or away from protection of natural resources, including aquifer classifications; new toxicological data or reinterpretation of existing toxicology; or the integration of facts regarding groundwater quality into conservative measures toward the safe use of all water resources.

LOCATING SUITABLE GROUNDWATER SUPPLIES

The goal of groundwater exploration is to locate productive aquifers that yield sustainable high-quality water. The production level and quality required will guide exploration efforts, but interest will generally center on locating large deposits of the following:

- Unconsolidated sands and gravels of alluvial or glacial origin
- Sandstones and conglomerates
- Limestones and dolomites
- Porous or fractured crystalline or basalt rocks

Many other types of rock can yield small quantities of water to meet the domestic needs of a single household on its own well.

Depending on the region, the starting place of the exploration effort will vary. In undeveloped regions, reconnaissance-type interpretation of aerial photos and maps may be the first step. Light Detection and Ranging or Laser Imaging Detection and Ranging (LiDAR), high resolution photogrammetry and infrared photos of land use, foliage patterns, foliage types, and water bodies may serve as an indicator of recharge efficiency. Areas having the greatest surface-drainage capacity (i.e., paved areas) will have the least amount of groundwater recharge and may or may not overlie significant groundwater resources. Cross-sectional maps may have to be drawn from surface geologic information and existing well logs. These maps will aid in determining the location, depth, and thickness of favorable aquifers.

In many regions, general cross-sections and hydrogeologic interpretations will already exist, along with well logs and production information from existing wells. In these cases, favorable aquifers will have already been identified, and exploration efforts can fill in the details of the local hydrogeologic environment. Surface geophysical methods, borehole geophysical methods, aquifer testing, exploratory drilling, and lithologic logging are the most common methods used to accomplish these efforts. More details on these are available in Bloetscher et al. (2007) or Keys (1989).

Geophysical Methods Without Drilling

Geophysical methods, principally electrical resistivity and seismic reflection and refraction, can be used without penetrating the ground to provide a more complete picture of subsurface structure, given some prior knowledge obtained from surface geology and borehole logs. A general model of the subsurface geology should be developed to provide the basis for a proper interpretation of the geophysical data. The information generated can be used to locate sites for further investigation with test drilling. In circumstances of well-defined subsurface geology and well-documented groundwater movement, contaminant plumes may be projected using geophysical methods of measurement.

Successful application of any geophysical method depends on the presence of distinct changes in the physical properties. The detectable physical properties provide only indirect estimates of the hydrogeologic properties, with the accuracy of such estimates depending on how closely these physical properties relate to each other. In addition, the structural configurations amenable to investigation must be relatively simple to separate from one another. A comprehensive reference on the use of geophysical methods for groundwater investigations is given by Zohdy et al. (1974).

Land parcels that often do not lend themselves to geophysical methods include areas consisting of large cobbles in alluvium, areas of severely distressed geology, or areas in which (in geologic time scale) high hydraulic energy was dissipated.

Electrical resistivity. Electrical resistivity is probably the most commonly used geophysical method for groundwater investigations. It is economical to apply, and it produces useful information.

In the direct-current resistivity method, electrodes placed into the ground transmit current through the earth, and voltage potential is measured between two points near the center of the generated field. Figure 2-1 schematically illustrates the most common electrode arrangements—the Schlumberger array and the Wenner array. Sets of resistivity readings can be gathered along the transect with constant electrode spacing (horizontal profiling) or at one location with expanding electrode spacing (electrical sounding). The first method will show apparent resistivities of materials at roughly the same depth along the transect, while the second method produces a depth profile of resistivity.

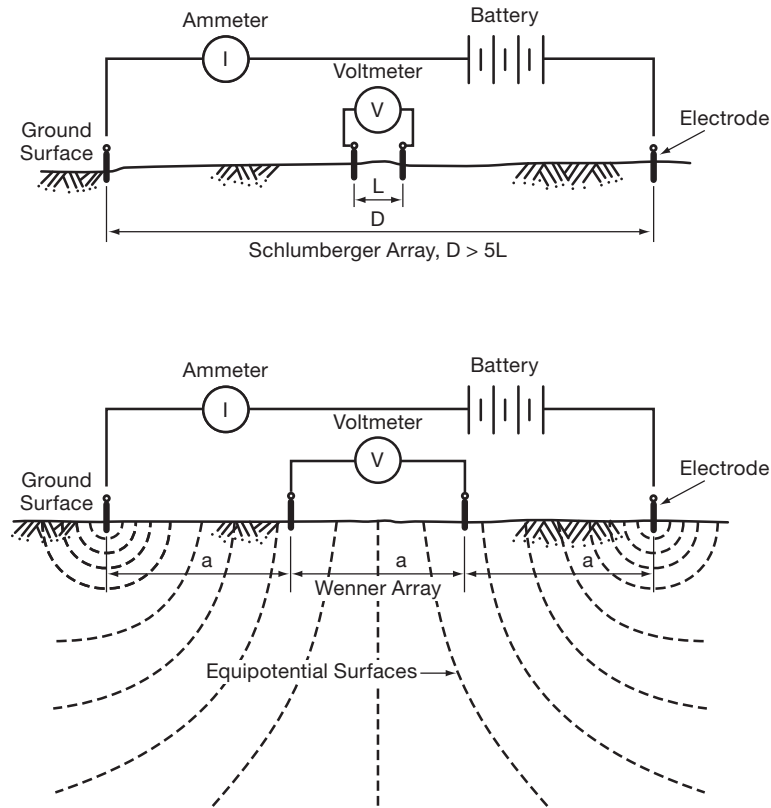

Figure 2-1 Schlumberger and Wenner electrode arrangements for measuring earth resistivity

Electrical resistivity is strongly affected by water content, thus interpretations involving the unsaturated zone are quite difficult as a result of the undefined distribution of moisture. In the saturated zone, resistivity is largely determined by the rock-matrix density and porosity, or by the saturating-fluid salinity (electrical conductivity).

Holding other factors constant, coarse sediments with low clay content will have higher resistivity than fine-grained sediments. This difference in resistivity makes it possible to map buried stream channels or perform depth profiling of shale-sandstone sequences. Such changes in mineral quality are detectable because of the relation between dissolved solids and electrical conductivity. Resistivity values for earth materials range over more than 16 orders of magnitude, and resistivity surveys can provide useful results in most environments with simple geologic structure and distinct resistivity contrasts.

Electrical resistivity may be used in existing or new well fields that require evaluation of suspect chemical migration from a polluting source. Plumes of discharged chemicals commonly have a relatively high dissolved-solids content. The boundaries of such plumes may be mapped with resistivity surveys, under the proper conditions.

The Schlumberger and Wenner arrays (see Figure 2-1) provide the simplest interpretation for measuring resistivity. The apparent resistivity R_a is given by

$$R_a = 2 \pi a V/I \quad (\text{Eq. 2-1})$$

Where:

- a = the electrode spacing
- V = voltage
- I = direct current

The apparent resistivity characterizes a volume of earth extending below the electrode array to some effective depth of penetration. The depth of penetration is related to the electrode spacing. For the Wenner array, the effective depth of penetration is commonly assumed to be equal to a . However, this assumption can lead to serious errors in calculated depths. The depths to horizontal boundaries are best determined by matching the theoretical apparent resistivity and electrode spacing curves of various model conditions to the curves obtained from field measurements. The Schlumberger array provides better resolution of subsurface features but is slightly more difficult to analyze. Interpretations should be performed by a trained analyst familiar with local conditions.

The resistivity method is generally limited to use in simple geologic environments with two or three distinct layers and where depth of penetration is limited to about 1,500 ft (460 m). Best results are obtained when the depth to groundwater is small, due to the complications of unsaturated materials. Also, the method is less effective in urban areas where the presence of buried metal pipes, wires, and similar obstructions can dominate measurements with unwanted noise.

Other geophysical methods that fall within the electrical methods category include telluric, magneto-telluric, electromagnetic, and induced polarization methods. However, their use is not generally applicable to groundwater supply investigations. Electromagnetic methods have become popular for shallow groundwater investigations, especially those involving groundwater contamination. The results are similar to those derived from the direct-current resistivity method, although resolution is poorer and exploration is generally limited to the upper 180 ft (55 m). The method has received attention because it involves no direct contact with electrodes, making it quick and easy to apply in the field. The other methods mentioned have some application in specialized research and are discussed by Zohdy et al. (1974).

Seismic refraction and reflection. Seismic methods are perhaps the most useful geophysical tools for hydrogeologic investigations, although costs are relatively high. Seismic methods use contrasts in the velocities of elastic wave propagation between different earth materials. For example, unconsolidated sands and gravels exhibit low propagation velocities, whereas crystalline rocks exhibit the highest propagation velocities. Propagation velocities are higher in saturated materials, providing for detection of the water table.

Elastic waves are commonly initiated with the use of explosive “shots” in shallow borings, although the use of truck-mounted hydraulic earth vibrators (thumpers) is fairly widespread. Lines of geophones are laid out on the ground surface to detect waves refracted or reflected from various subsurface discontinuities to measure travel time. Travel time records can then be analyzed to produce a picture of the subsurface. As with any geophysical methods, the interpretation of seismic data requires an assumed model of subsurface structure; the more preexisting information geologic data and borehole logs that are available, the more reliable the results from seismic surveying will be.

Reflection and refraction are two methods of seismic exploration. While reflection is defined as a wave that rebounds off a surface, in refraction that wave is bent as it passes through a boundary between two media. Seismic reflection is not generally used for groundwater investigations but is preferred for petroleum exploration. The cost and complexity of equipment and analyses required to apply the reflection method is greater than that required for the refraction method. For deep groundwater exploration in multilayered environments, however, the reflection method is generally superior.

Seismic refraction is the most commonly applied method in groundwater investigations. Besides cost considerations, this method can have advantages in environments where deep alluvial or glacial fill exists. Less knowledge is required to apply refraction seismology, and good results can usually be achieved in most groundwater investigations. The most severe limitation of seismic refraction is that return signals can only be obtained

as long as each successively deep layer has a higher propagation velocity than the overlying layer. In areas of scarce water, where water wells are drilled to great depths (for example, parts of the arid southwestern United States), this limitation may prove too restrictive, and the higher cost of seismic reflection may be warranted.

Figure 2-2 shows the use of the seismic refraction method for reconnaissance mapping of the depth to bedrock and the location of a buried stream channel. Seismic refraction can be used to determine the thickness of surficial fracture zones in crystalline rock and to map the depth and thickness of subsurface layers, up to at least the equivalent of three layers. As in the resistivity method, the analyses become very difficult and the results less reliable for more than three layers.

As long as the geologic structure is simple, depths of a few thousand feet (600 to 700 m) can be explored with seismic refraction, given a sufficient explosive and deep shot. Seismic reflection can be used to gather information from more than 10,000 ft (3,000 m) deep. For small area applications, where only very shallow materials need to be explored, more rudimentary methods with less seismic equipment may be employed.

Other methods. Other geophysical methods can be useful in groundwater investigations, although none have been widely used due to the low benefit-to-cost ratio associated with their use. Some relatively new methods, such as ground-penetrating radar, have proved useful in groundwater contamination studies; however, the depths of penetration may be too shallow for general use in water supply applications. Gravity methods and magnetic methods have been used for general hydrogeologic investigations, although they must be viewed as supplementary methods to be applied in situations where maximum information is desired and cost is not a limiting factor. These methods are discussed by Zohdy et al. (1974).

Borehole Geophysical Logging

Borehole geophysical logging has become a common tool in groundwater exploration. The technology of borehole logging is quite involved, and experts using special equipment are needed to perform the logging and interpretation. The discussion here introduces the capabilities and limitations of the logging tools found to be most useful in groundwater exploration. There are many texts on borehole logging, but the reader should be cautioned that most of these texts present information tailored for use in petroleum exploration. The presence of low or nonsaline water in a formation mandates the use of special analyses for interpretation. For a detailed discussion of this subject,

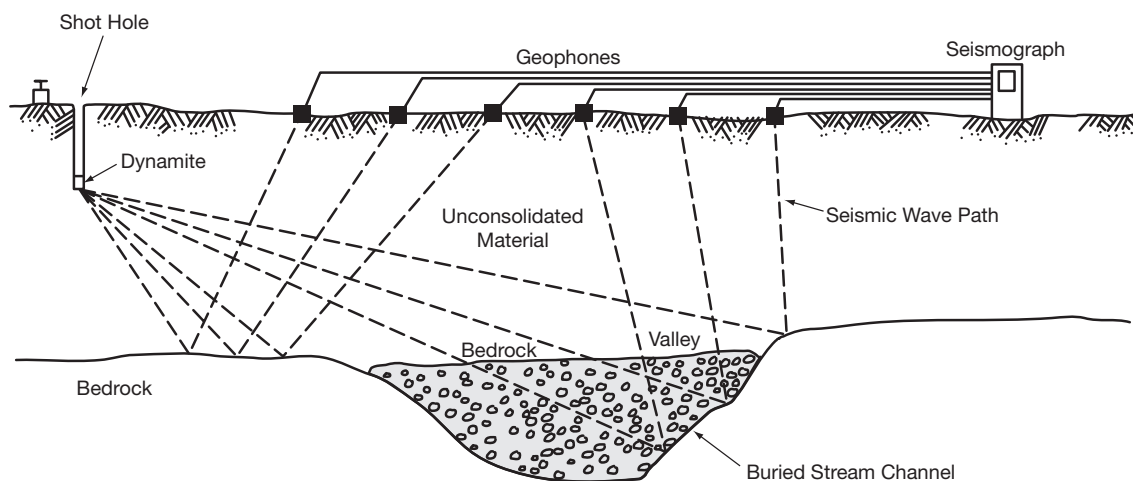

Figure 2-2 Application of seismic refraction method for reconnaissance mapping

the reader is referred to Keys and MacCary (1971) or to Keys' *Borehole Geophysics Applied to Groundwater Investigations*, as published by the National Water Well Association (1989).

There are many borehole logging techniques available, although electrical, naturally occurring gamma radiation, and caliper measurements are the most widely used. All geophysical log measurements are obtained by lowering a probe down the borehole and recording continuous measurements with depth. Logging is frequently performed during drilling operations, and quick analyses of the logs by qualified personnel provide the basis for decisions regarding well completion, including depth of casing and screened intervals. Some types of logs must be performed in an uncased well, while other logging can be done in cased wells, allowing data collection from existing wells.

Performing multiple logs in a single well will provide confidence in interpretations. Each type of log measures different physical properties, and combined analysis may resolve ambiguities that might exist from a single log. The greater the number of wells logged in an area, the greater the statistical confidence in the data and interpretations as being representative of the subsurface environment.

Determining the number of wells and the types of logs to be used in an investigation is often difficult. Most groundwater investigations obtain adequate information using caliper, resistivity, spontaneous potential, natural gamma, and lithologic logging as described in the following sections. The cost of these techniques should be evaluated in the context of the time available, accuracy needed, and the basic purpose of the survey.

Caliper logging. Caliper logging is used to measure the diameter of the borehole. A probe that usually has either three or four levered arms is brought up through the hole, while a record of the depth and degree of extension of the arms is made at the surface. Four-armed probes can be used to measure the diameter of the hole in two directions and thus permit the evaluation of the asymmetry of the borehole. Caliper logs are of importance in groundwater exploration and well construction because the interpretation of other borehole geophysical logs requires data on the borehole diameter. Caliper logs can provide indications of the presence of high-permeability, fractured, or cavernous zones, as well as the occurrence of swelling clays and well lithified layers in friable or unconsolidated rock or sediment. Caliper logs are commonly run before the cementing of well casings to determine the volume of the annular space and to locate uniform diameter areas of boreholes in which to set cement baskets and packers.

Electrical resistivity logging. Electrical resistivity logging measures the apparent resistivity of the formations in a borehole. According to Ohm's Law, resistance (ohms) is equal to potential (volts) divided by current (amperes).

$$R=V/I \qquad \qquad \qquad \text{(Eq. 2-2)}$$

Where:

- I = current through the conductor (amperes)
- P = potential difference measured across the conductor (volts)
- R = resistance of the conductor (ohms)

Electric resistivity logs use Ohm's Law to determine the apparent resistance of the formations in the borehole. A current is applied between a downhole electrode and an electrode at the surface. The potential (voltage) is then measured between a downhole electrode and a surface electrode or between two or more downhole electrodes. Variations in the measured resistance are related to the composition of the rocks and sediments and the salinity of pore waters. Silt, clay, and shale tend to have the lowest resistivities; sands, sandstones, and limestones with nonsaline pore waters have the highest resistivities.

The simplest and least expensive electric resistivity log is the single-point resistance log, illustrated in Figure 2-3. The single-point resistivity log measures the potential drop between a surface and downhole electrode, which are also the current electrodes. The single-point resistivity log is used primarily for geological correlation and the location of bed boundaries, changes in lithology (rock characteristics), and fracture zones. Single-point resistivity logs have a very good vertical resolution of changes in the gross physical characteristics of a rock formation, or lithologic changes, but do not provide quantitative data on formation porosity or pore water salinity.

Separate current electrode and potential electrode(s) are located on the downhole probe in normal resistivity logs. Normal resistivity logs measure the apparent resistivity of a volume of the formation perpendicular to the borehole electrodes. The size of the volume of investigation is proportional to the electrode spacing. The probes are commonly configured so that short normal (16-in. electrode spacing) and long normal (64-in. spacing) resistivities are measured simultaneously. Normal resistivity logs are commonly used in groundwater investigations as a source of qualitative information on water quality. True formation resistivity and salinity can be calculated from the measured apparent resistivities, but the calculations require the application of a number of correction factors, whose values are estimates. Other types of resistivity logs that are less commonly used in groundwater investigations are discussed by Keys (1989).

Spontaneous potential logging. Spontaneous potential (SP) logging was the first type of downhole, geophysical log. Spontaneous potentials are the naturally occurring electrical potentials that develop at the contacts between beds of different types of geological materials, such as between shale and sandstone beds. The SP logging apparatus consists of a surface and downhole electrode connected to a voltmeter. The SP logging equipment is usually incorporated in the electric resistivity log apparatus. SP logs provide information regarding geologic correlation, bed-thickness determination, and changes in lithology. Log definition depends on the contrast in fluid conductivity between the borehole and the geologic formation penetrated.

Gamma logs. Gamma logs record naturally occurring gamma radiation emitted by earth materials. The most significant natural resource of gamma radiation is the decay of the potassium-40 isotope and the daughter products of the uranium and thorium decay series. Rocks and sediments with relatively high concentrations of potassium, uranium, and thorium give high gamma ray counts. Clay-rich rocks, such as shales and phosphatic rocks in particular, give high gamma ray counts, whereas nonphosphatic limestones and dolostones and clean quartz sandstones tend to give low gamma ray counts. The gamma log is by far the most commonly used nuclear log and is very valuable for geological correlation and lithologic determination (note: it contains no nuclear material but measures background gamma radiation in the formation). The gamma log is useful because it can be run in cased walls.

Gamma-gamma logs. Gamma-gamma logs (also called *radioactive tracer logs* or *surveys*) are obtained by introducing a gamma radiation-emitting material into the borehole (usually cesium-137 or cobalt-60) and measuring the intensity of the back-scattered radiation. The back-scattered radiation detected by the probe is proportional to the density of electrons in the formation, which is in turn correlated with the bulk density of the rock. Gamma-gamma logs provide information on lithology and porosity. This log can also be used to locate cavities in the cement outside of a well casing. Gamma-gamma logs are widely used in the oil industry, but are rarely used in groundwater investigations because of their high costs and the liabilities associated with the potential loss or rupturing of the radioactive source within the aquifer.

Neutron logging. Neutron logs are obtained by introducing a radioactive source that emits neutrons into the borehole. The emitted neutrons interact with hydrogen atoms

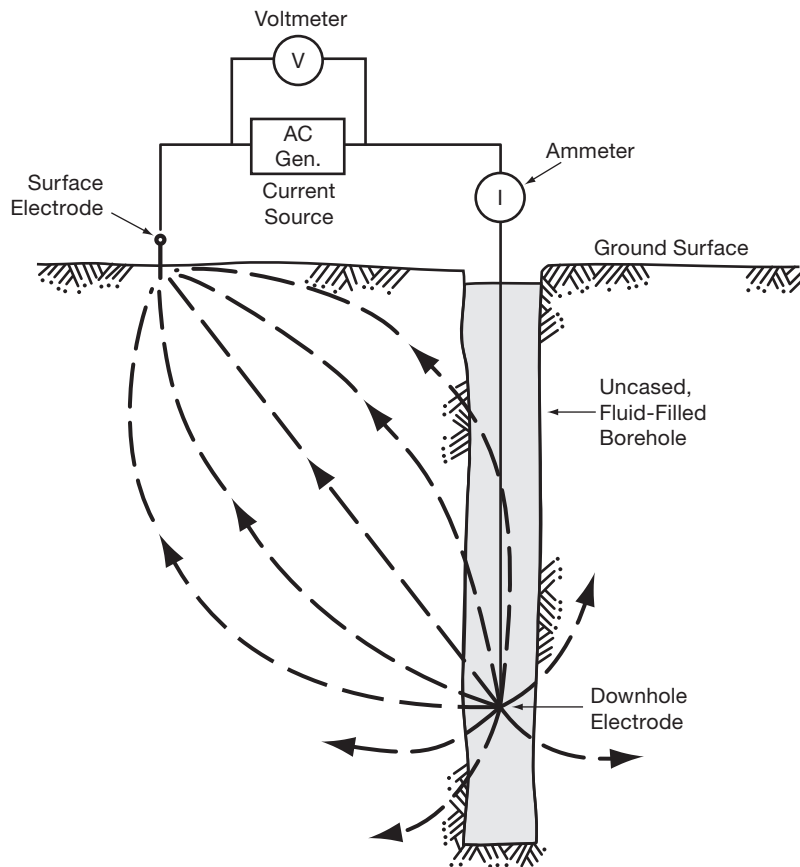

Figure 2-3 Single-point electrode arrangement for resistance and spontaneous potential logging

and release gamma radiation, which is measured by a detector on a logging probe. The intensity of the measured gamma radiation is proportional to the hydrogen atom concentration and thus water content and porosity of saturated rocks. Neutron logs are widely used in the oil industry to determine the porosity and water content of formations and lithology. As is the case with gamma-gamma logs, neutron logs are not often used in groundwater investigations because of their high costs and the liabilities associated with the potential loss or rupturing of the radioactive source within the aquifer.

Acoustic logging. Acoustic or sonic logging involves the recording of transit time of acoustic pulses radiated from a probe in a borehole to one or more receivers also located on the probe. Transit times are related to matrix mineralogy and the porosity of the rock. Transit times decrease and acoustic velocities increase in sedimentary rocks with increasing hardness and cementation. Most rock types have a limited range of travel times, which allows for acoustic logs to be used to determine lithology. Porosity and fracturing can also be approximately determined from acoustic logs. The cement bond log is a type of acoustic log that is used to determine how well a well casing has been cemented to the formation.

Fluid logs. Fluid logs include temperature, fluid resistance, and flowmeter logs. The probe used for temperature logs usually contains a glass bead thermistor. Temperature logs can be used to identify the boundaries of aquifer zones in boreholes because as water flows through permeable zones, the normal geothermal gradient will vary. Temperature logs can also be used to detect inter-aquifer flow either up the borehole or down the borehole, depending on the differential head pressure that is present. The presence of cement grout in the annular space of a well can be determined by running a temperature

log within 24 hr of grouting because the heat of hydration of the cement raises the fluid temperature in the casing in cemented areas.

The fluid resistivity (or conductivity) probe contains two internal electrodes that measure the capacity of the borehole fluid to conduct electricity. The conductivity of a fluid increases with increasing salinity and temperature. A salinity versus depth profile can be constructed for an open borehole using the results of a temperature and fluid resistivity log. The calculated salinity versus depth profile is subject to considerable error because of the flow within the well.

Flowmeter logs are used to measure flow velocity within the wells. The most common construction is the impeller-type where the rate of rotation of the impeller is proportional to the relative flow velocity of the probe. The relative flow velocity includes the actual flow velocity of water in the well and the rate at which the probe is being raised or lowered into the well. Caliper logs must be run with the flowmeter log because the flow velocity is a function of the cross-sectional area of the borehole. The relative contribution of individual aquifer zones to the total flow from a well can be calculated using data from flowmeter and caliper logs.

Hydrophysical logging. Hydrophysical logging is a new form of borehole logging where demineralized water is introduced into the borehole and the dispersion of the demineralized water is continuously logged with respect to time. This allows a more accurate measure of calculating variations in the formation's hydraulic conductivity.

Log suites. In most instances, individual borehole geophysical logs do not provide unequivocal lithological information. By running a suite of logs, more accurate qualitative and quantitative information on formation porosity, hydraulic conductivity, bulk grain density, and fluid conductivity could be extracted. Figure 2-4 depicts a qualitative interpretation of a suite of geophysical logs. A high gamma ray count, for example, could be produced by a shale bed or phosphatic limestone layer, and shale layers are identifiable by a low-resistivity and high-gamma log response.

Aquifer Testing

In the simplest form, recording flow rates of the water produced at different depths while drilling with air is a form of aquifer testing, yielding valuable information. Aquifer testing is very useful during exploration of test holes, and many effective methods are now available for performing such testing. Methods of aquifer testing will be discussed in detail in chapter 4.

Exploratory Drilling

In some instances, existing wells may not be located in a potential water supply aquifer, and drilling one or more exploratory wells into the aquifer is necessary. Exploratory drilling is performed to determine an aquifer's characteristics, including hydraulic conductivity, water quality, thickness, and areal extent. The newly drilled wells can also be used for borehole geophysical logging and aquifer testing as previously described. The number and spacing of the wells drilled will depend on the size of the aquifer and the amount of water supply development planned.

Lithologic Logging

Lithologic logs are developed by drillers to describe the type of rocks and their characteristics. Lithologic logs and drillers' logs, including the drilling rate, are used with geophysical logs to obtain the most information about the groundwater. Geophysical logs can more accurately place the depth of discontinuities than can a lithologic log.

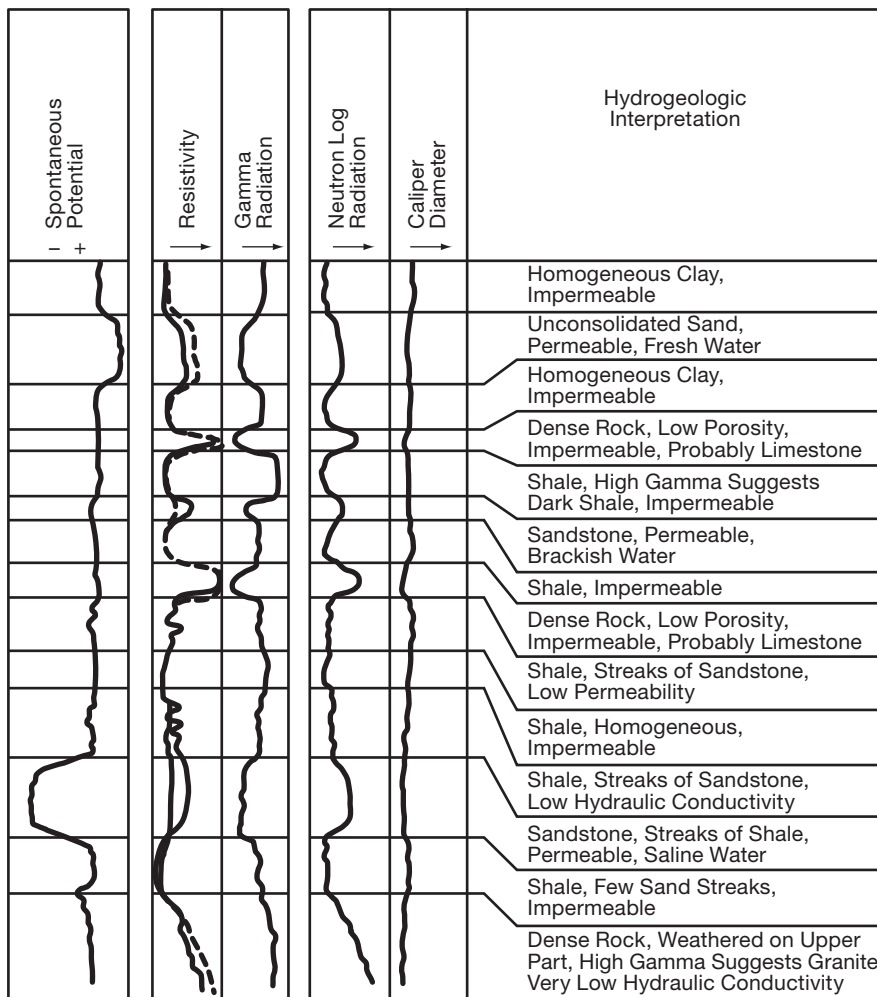

Figure 2-4 Qualitative interpretation of a suite of geophysical logs

Accurate lithologic logging during drilling is crucial, and a hydrogeologist experienced in well logging should be employed.

Application

There is no established order in which exploration methods should be applied; a balanced program of appropriate combinations will produce the most information. However, the knowledge gained through a geophysical investigation only extends the factual information gained from test drilling and adequate sampling.

MONITORING GROUNDWATER QUALITY

Before developing a groundwater supply, the water quality must be currently acceptable and expected to remain so in the foreseeable future. The SDWA and its amendments outline a series of water quality parameters that raise health and aesthetic concerns. Defining water quality will permit the appropriate treatment to be designed. This initial assessment can provide a basis for legal action against anyone who contaminates the water

supply after development. After the initial water quality assessment is performed and groundwater development is assured, a system for monitoring water quality should be maintained, and a reassessment of upgradient contamination risks should be performed periodically.

Monitoring Wells

In areas where contamination risks are high, sentinel monitoring wells should be installed. These wells, located at various depths, will provide definition for the initial groundwater assessment. Sentinel wells also serve as an early-warning system to detect changes in water quality and water elevations before they affect the water supply wells. In recent years, equipment for sampling from monitoring wells has become widely available. Small submersible or portable pumps can be installed into well casings as small as 1 in. (25 mm) in diameter, although it is common for monitoring wells to be at least 4 in. (100 mm) in diameter and made with polyvinyl chloride casings.

The number of wells needed and their locations, depths of completion, and construction details must be specified as part of an integrated plan. The plan must account for likely sources of contamination, local hydrogeology, and the hydraulic effects of the proposed groundwater development. For example, what was previously considered downgradient from the well can become upgradient either after pumping begins or as influenced by nearby surface water. These changes should be simulated with computer modeling to aid in designing a monitoring-well network.

The initial assessment may indicate that one monitoring well is sufficient to begin with, but an increased contamination threat in future years (for example, due to local growth and development) could indicate a need for additional monitoring wells. This potential for development demonstrates the importance of continual evaluation of changes that might affect the groundwater supply. One suggestion is to reverse the potential pollution site monitoring requirement of one well upgradient and three downgradient for a permitted hazardous waste site. Therefore, the water supply agency would be responsible for three wells upgradient and one downgradient.

Sampling

Multilevel sampling capability that ensures against the possibility of a monitoring well acting as a conduit for vertical migration of contaminants should be used. Several techniques are available, including locating several wells of differing depths in close proximity to one another (cluster wells) and using multiple-completion monitoring wells that consist of a nest of piezometers installed in a single borehole, as shown in Figure 2-5.

Proper construction of multiple-completion wells is not an easy task, but it can offer cost savings. Materials must be properly placed into the well bore. For example, the perforated portion of each piezometer must be isolated from the others in the nest so that fluid pressures and water quality can be monitored correctly at that isolated level. Three-dimensional data collected using a network of multilevel monitoring wells should provide a useful definition of contaminant distribution, although the cost of such information may be high.

Analysis. Samples taken from monitoring wells should be analyzed for suspected contaminants, including severe mineralization. The mineral quality of water will limit the range of possible water uses. For example, hard water (high concentrations of calcium and magnesium) will be unsuitable for boiler feed water. Water containing high concentrations of sodium or boron will be unsuitable for irrigation. Although the biological quality of deeper groundwater is usually good, testing for fecal bacteria and other microbiological indicators should be performed periodically.

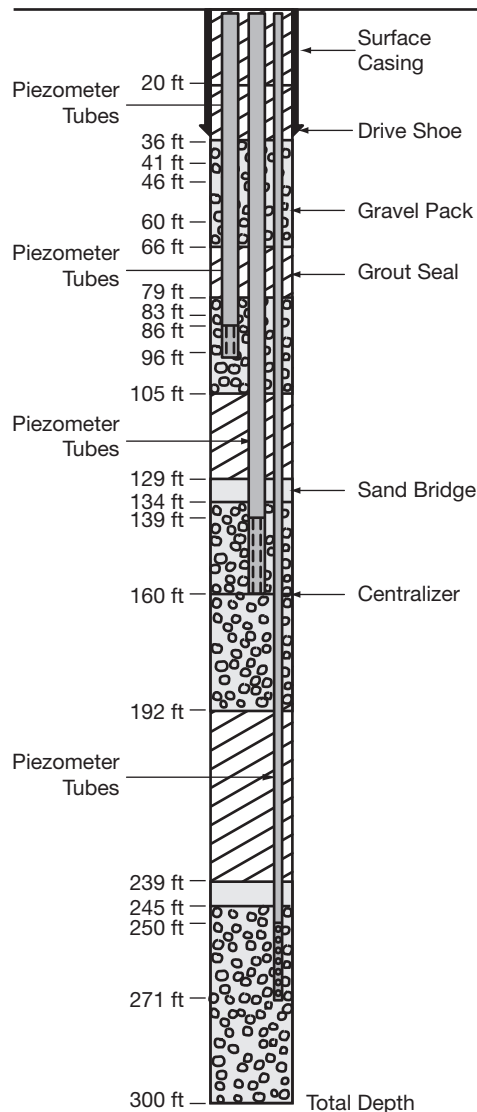

Figure 2-5 Schematic of a multiple-completion monitoring well

In recent years, a wide variety of constituents that can be harmful even in extremely low concentrations have become a concern. Unfortunately, analyses to detect all of these chemicals can be expensive, so analytical methods used should be directed toward detection of suspected compounds. Knowledge of probable sources of contaminant chemicals used in the area and selection of any key indicator constituents should be used in the design of the sampling and analysis program to reduce cost without loss of study credibility. Guidance for selecting chemicals to be tested may be obtained from state and federal regulatory officials responsible for facility permits. Indicator parameters, referred to as *priority pollutants*, often can be used to determine the likely presence or absence of chemicals that are a concern to groundwater development.

Fortunately, groundwater quality in many locations does not change because of shallow gradients, i.e., movement of groundwater is very slow, especially compared with surface water quality. Therefore, once water quality has been established, the frequency of groundwater sampling normally need not exceed quarterly or even semiannual checks, except for potable water sources or areas of suspected contamination.

FIELD LOGISTICS AND DOCUMENTATION

Land costs, permits, professional services, and documentation are very important to the evaluation of potential water supply sites.

Land Costs

Legal access to property for preliminary groundwater investigation will commonly be granted by the landowners on request. However, as soon as a property has been identified as attractive for detailed exploration, purchase or lease options should be obtained. The cost of land may be more reasonable before good water supplies are confirmed. Drilling site preparation and restoration should not be overlooked as added costs to the groundwater development.

Permits

Exploratory drilling permits must be secured and fees paid, often at the state or county level. Obtaining permits is usually the responsibility of the well driller or the engineer in charge. In addition to the driller, a qualified hydrogeologist often supervises the drilling and well-construction activities. The hydrogeologist's responsibilities will usually include procuring well construction materials, well logging, conducting or overseeing geophysical logging, interpreting logs, well designing, and certifying as-built drawings.

Part of the drilling permit will include proper abandonment once the well has served its purpose. Public agencies are concerned about well construction and post-use of a well because of the possibility of cross contamination between shallow zones and deeper high-quality aquifers. The documentation of all field work can be valuable in later phases of groundwater development or protection. Proper land survey location, global positioning system (GPS) locations, description of the wells, and complete as-built drawings of construction are desirable.

Professional Services

Firms specializing in hydrogeology are valuable to the groundwater developer for their knowledge and experience in carrying out fieldwork and preparing the necessary reports. Some firms offer total services in groundwater development, as well as highly specialized equipment or services. Budget constraints, the complexity of the project, and the adequacy of the groundwater developer's staff can determine the most appropriate team. Some states require registered engineers, certified geologists, and other professionals to verify the accuracy and completeness of fieldwork.

Documentation

Documentation of initial investigations and water supply development must be detailed and complete. Because of the complex nature of the information, the use of graphics is helpful. Cross sections (Figure 2-6) showing the hydrogeologic interpretation, with lithologic logs, geophysical logs, and as-builts for wells, present a good summary of information. Maps showing predevelopment groundwater contours versus the contours as affected by the new pumping, including surrounding land uses and any potential sources of groundwater contamination, should be available. Figures 2-7 and 2-8 illustrate such maps.

Legal documents. Multiple copies of reports pertaining to groundwater development may be required by different levels of government for differing purposes. If the required reports are not to be submitted on issued forms, a reporting system that meets the needs of all federal, state, and local organizations should be designed.

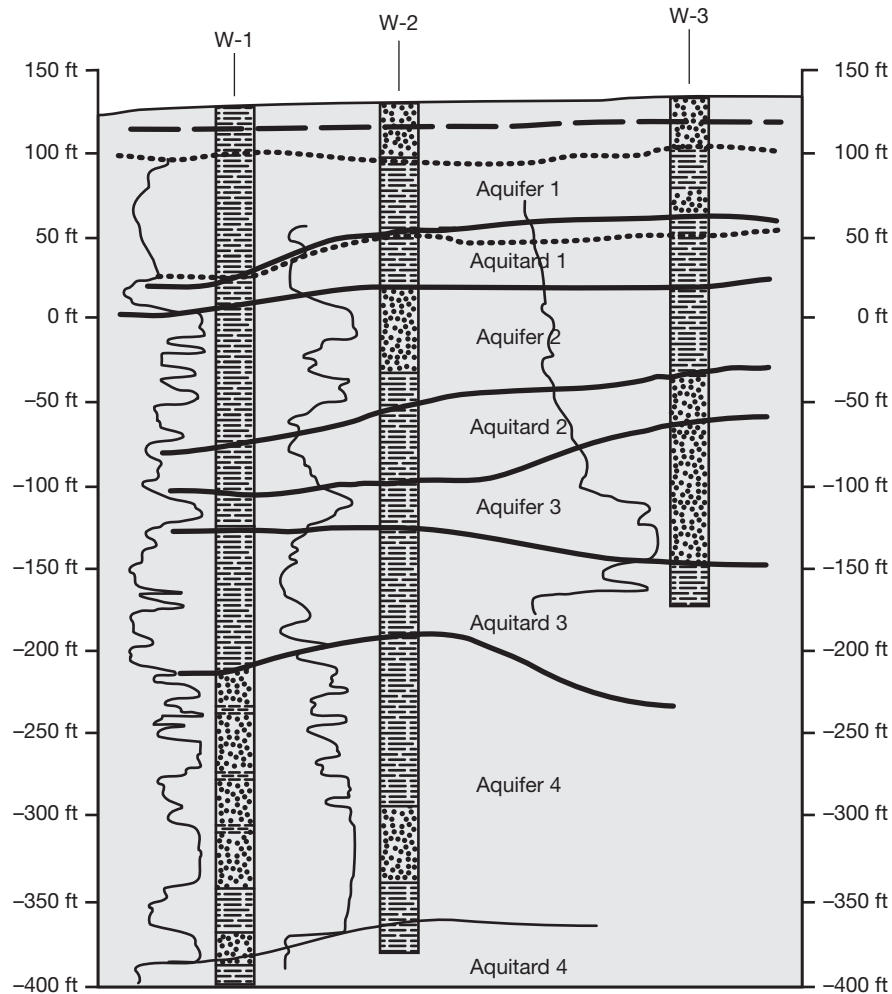

Figure 2-6 Graphic detail of a hydrogeologic cross section

Because federal, state, and local laws are requiring more information to be filed on a periodic basis, permits must be filed, fees must be paid, and monitoring must be conducted. These activities should be part of the planned groundwater development program. It may be desirable to consult an attorney knowledgeable in all aspects of the law, including groundwater, land use, and permit procedures, before finalizing reporting procedures. Reports can be of great value in litigation and, therefore, should be prepared with care and be subjected to appropriate legal, technical, and managerial review.

Application. In addition to the traditional groundwater quantity reporting (along with the few inorganic analytical tests), more extensive testing for organic contaminants is being required. Water conservation interest groups are using the pumping data to predict available groundwater supply and look for indications of groundwater mining. Information is also being filed with various government agencies involved in groundwater monitoring of facilities that produce, handle, store, treat, or dispose of chemicals determined to be hazardous to health or the environment. This information, when combined with information provided by the groundwater developer, can increase understanding of the regional groundwater system under study and its potential and reliability as a water supply.

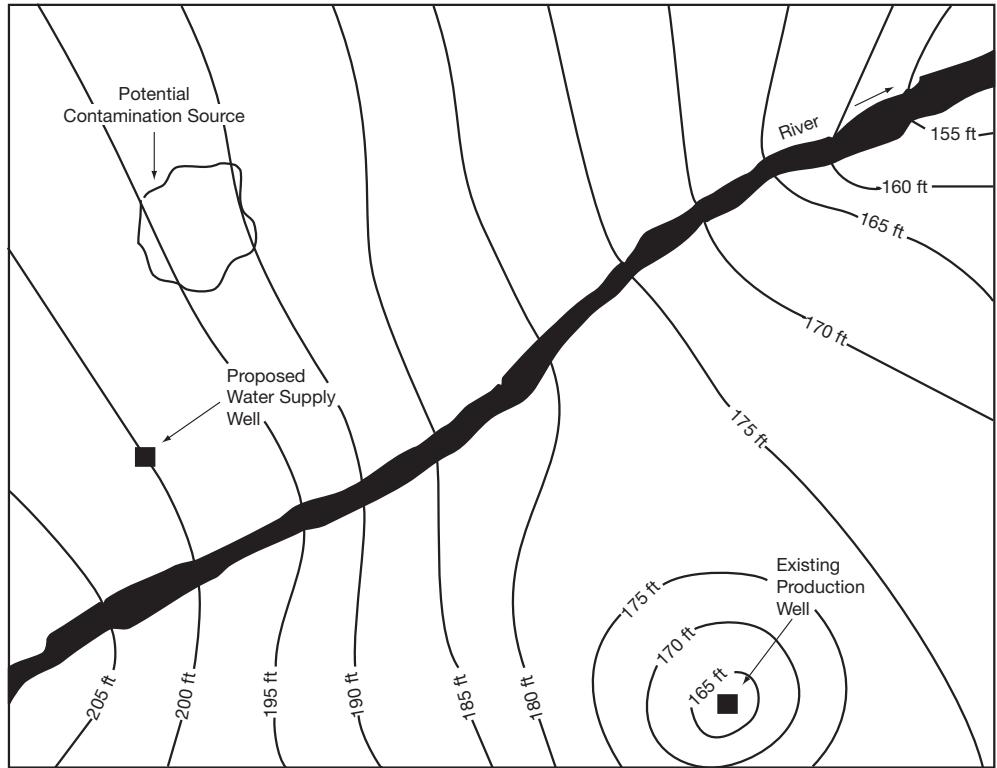

Figure 2-7 Predevelopment groundwater contours showing potential contamination source downgradient

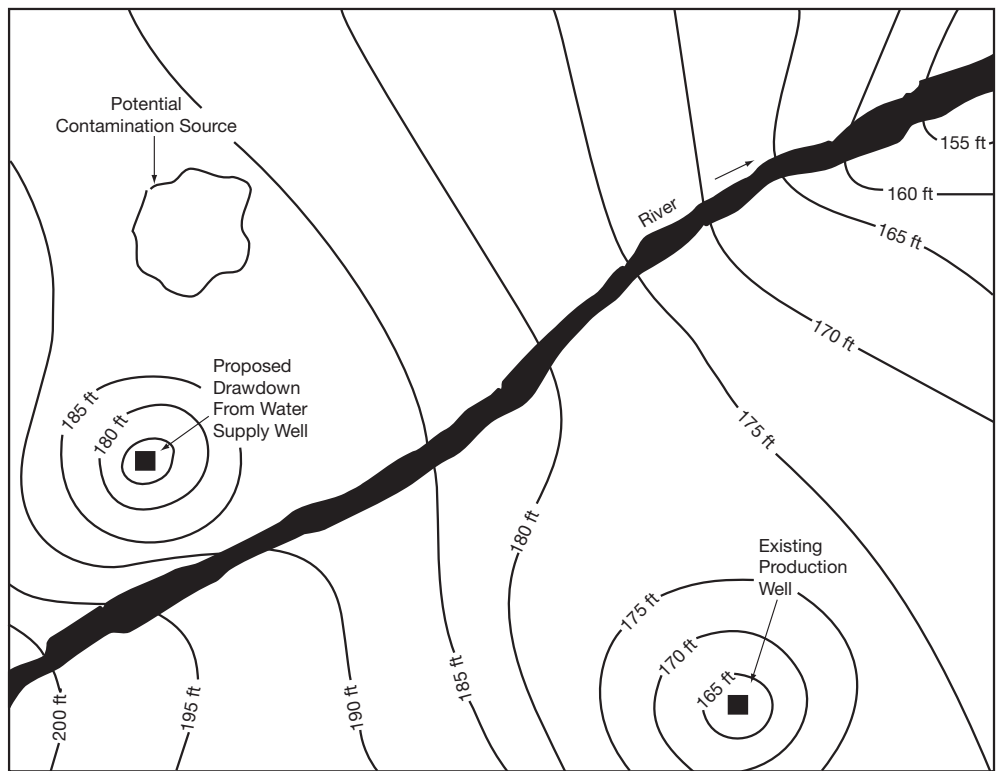

Figure 2-8 Predevelopment groundwater contours showing predicted effects of ill-advised development

REFERENCES

- Bloetscher, F., A. Muniz, and J. Largey. 2007. *Siting, Drilling, and Constructing Wells*. Denver, Colo.: American Water Works Association.
- Keys, W.S. 1989. *Borehole Geophysics Applied to Groundwater Investigations*. Westerville, Ohio: National Water Well Association.
- Keys, W.S. and L.M. MacCary. 1971. Application of Borehole Geophysics to Water-Resources Investigations. *Techniques of Water-Resources Investigations*, Book 2, Chap. E1. Denver, Colo.: US Geological Survey.
- Todd, D.K. 1984. *Ground-Water Resources of the United States*. Berkeley, Calif.: Premier Press.
- US Geological Survey. 1978–1982. Appraisals of the Nation's *Ground-Water Resources*. Prof. Paper No. 813, Chap. A-U. Denver, Colo.: USGS.
- Zohdy, A.R., G.P. Eaton, and D.R. Mabey. 1974. Application of Surface Geophysics to Ground-Water Investigations. *Techniques of Water-Resources Investigations*, Book 2, Chap. D1. Denver, Colo.: US Geological Survey.

This page intentionally blank.

Groundwater Management and Protection

The overall goal of groundwater management is to reliably provide sufficient water to sustain urban, agricultural, and environmental needs over time. Groundwater management is becoming increasingly complex, as a result of the constraints from water quality legislation and regulation, and with respect to the sustainability issues outlined in chapter 1. Surface water supplies have become more constrained, and development of well technology has allowed people to move to arid regions and to irrigate acreage that was not farmable 70 years ago. As a result, groundwater has played an increasingly important role in water supply for urban and agricultural users.

Aquifers are often managed by local or regional agencies or, when legally adjudicated, by a court-appointed arbitrator, but the means varies across the United States. Because of the geographic extent of many aquifers, the current system may not capture the true impact of local withdrawals. Local and court regulations are typically driven by water quantity issues, not quality issues. Water pumped for municipal supply is subject to state and federal water quality standards, the latter taking precedent over the former.

This chapter aims to illuminate groundwater management issues by first elaborating on the motivation for management and protection. From there, regulatory approaches are described followed by a discussion of source water protection and general management strategies. Contaminated groundwater management strategies are then examined in more detail as well as the different facets of regional groundwater management. The chapter concludes with a discussion of groundwater sustainability and how that may affect management strategies in the future.

INTRODUCTION

Groundwater is often perceived to be “better” than surface waters, or even “pristine,” because contamination pathways into groundwaters are not as obvious as they are for surface waters. However, groundwater systems are as susceptible to contamination as surface waters, and may be subject to contamination for more significant periods of time because of the slow movement of the water. Groundwater-related disease outbreaks and associated illnesses have risen as a result of contamination from both chemical and biological concerns. In addition, many layers of rock that were previously thought to be highly confining may contain fractures or intrusions, such as wells that create pathways for contaminants to move into underlying aquifers.

Many studies have confirmed that groundwater contamination may be present in wells. Fertilizer application, inadequate maintenance of septic tanks, unlined wastewater holding ponds, and improper sludge or manure application sites are major contributors to nitrate contamination.

Considering the 673 waterborne illness outbreaks, affecting 150,000 people, that occurred in the United States between 1946 and 1980, 44 percent of those outbreaks were attributable to groundwater sources (Asano 1985). Further, Keswick et al. (1982) estimated that 50 percent of the waterborne illnesses in the United States in a given year originate from groundwater, and 65 percent of those are enteric viruses (Yates et al. 1985). More recently, between 1997 and 2006, 137 waterborne disease outbreaks were reported to the Centers for Disease Control, with a total of 8,498 illnesses and 17 deaths (Barwick et al. 2000; Blackburn et al. 2004; Lee et al. 2002; Liang et al. 2006; Yoder et al. 2008). Of the 101 outbreaks with a known cause, 17 were attributed to chemical or toxin poisoning and 84 to pathogens. Bacteria were the most commonly implicated pathogen.

Groundwater may also be “self-contaminating.” Groundwater aquifers may be physically connected, which allows movement of lower quality water into the production zone. Normally this is caused by improper well construction that allows poorer quality water to migrate from one formation to another past potential protective or confining layers through improper well design and/or well construction. Saltwater intrusion is an example of the production zone being contaminated by adjacent saltwater bodies. Infiltration may migrate surface or shallow subsurface wastes from spills, septic tanks, or any number of other possibilities into the production zone. Well construction may permit the flow of water from one aquifer to another. Aquifer degradation has resulted in aquifer management that has prevented overdraft. Regulations are now emphasizing protection and restoration of groundwater quality. Changes in water quality may suggest that a groundwater source or a treatment plant that meets current standards may be out of compliance in the future.

REGULATORY LEVEL MANAGEMENT

More groundwater contamination is likely to be found in the future, as decades of human activities, including waste discharges, agricultural practices, leaking underground fuel tanks (Figure 3-1), and manufacturing activities accumulate. Naturally occurring constituents can also impair groundwater quality, such as arsenic and barium. Simultaneously, drinking water regulations are both increasing in number and stringency from a few dozen in 1946 to more than 130 regulated contaminants today. In the future, it is projected that there may be as many as 200 regulated constituents.

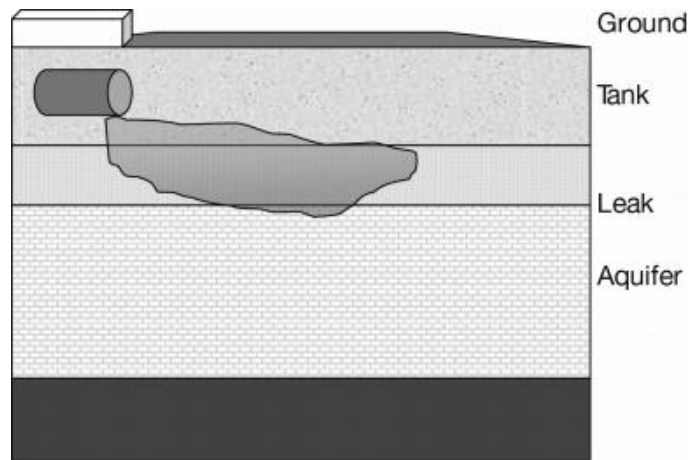

Source: Bloetscher 2011

Figure 3-1 Example of a surface activity that could affect groundwater through a leaky storage tank

When a site has been selected for installation of a well or well field, the water supply entity must protect it from contamination. Watershed protection can be broadly defined as a program to reduce the threat to water supplies from contaminants; for groundwater this is called a *source water protection program*. A source water protection program reduces the potential for contaminants to leach into the groundwater by identifying and managing recharge areas specific to the well field. Source water protection programs range from simple regulations concerning the location of facilities in the vicinity of the wells, to extensive land purchases and comprehensive land use restrictions, such as have occurred in Seattle, Washington, and the New York City water supply area.

The legal basis for a source water protection program is a mandate within the implementation of the 1986 amendments to the Safe Drinking Water Act (SDWA). Under Section 1428, each state must prepare a wellhead protection program and submit it to the US Environmental Protection Agency (USEPA) for approval (USEPA 1995). The protection of public water supply wells through wellhead protection programs is considered an important component of a comprehensive state groundwater protection program, as established by the US Environmental Protection Agency (1991).

The 1996 Amendments to the SDWA require states to implement Source Water Assessment Programs (SWAPs) to assess areas serving as sources of drinking water in order to identify potential threats and initiate protection efforts. Local communities can protect their groundwater resources by incorporating wellhead protection activities into land use management.

Since 1984, the Groundwater Foundation has been promoting the national Groundwater Guardian Program (Groundwater Foundation 1995), which recognizes, supports, and connects communities protecting groundwater. The program is made possible by grants from the US Geological Survey, USEPA, and others. This private foundation has been recognized by numerous national and international organizations, including being honored by the United Nations in 1990.

Most states have groundwater programs. For example, California has established a process for developing groundwater management plans for individual aquifers. Connecticut ranks aquifers according to levels of protection. For information about other state or provincial programs, contact the state's or province's division of water resources.

To address these concerns, states and provinces have implemented regulations to protect underground sources of drinking water. Some actions taken include:

- New requirements for installation and testing of underground storage tanks
- Increased regulation for handling, using, and transporting toxic chemicals to reduce the possibility of spills
- Greatly increased regulation of landfills and other waste disposal sites
- Closer control of the use of pesticides and agricultural chemicals, sampling and monitoring of identified groundwater contamination locations
- Action to remove the contamination

All of these programs affect land use, possibly affecting local constituents, especially where private property rights laws are an issue. They also affect the water agency because additional testing of water quality is required. The modeling the wells and well fields with sophisticated computer models like MODFLOW, will allow the institutional water system and associated oversight agencies to develop areas where certain activities should be limited. AWWA Standard G300 Source Water Protection provides many details.

SOURCE WATER PROTECTION

Source protection should be the first step in safeguarding public water supplies, reducing the need to use expensive alternative treatment techniques. Delineation of a source water protection area is typically done through the use of computer modeling of travel time and pollutant transport. These models can be complex and can create large areas where many land uses are prohibited. Such source water protection efforts can conflict with private property rights objectives. These laws indicate that if the property is damaged significantly (often defined as a devaluation of 10 percent), the regulating agency must pay the affected property owner. The concept of source water protection conflicts with this legal concept, which could be a significant impediment for utilities attempting to implement source water protection programs.

The management of a source water protection area to prevent contamination involves the following steps:

1. Identify protection options appropriate to the potential contaminants.
2. Select the options that are technically and politically feasible.
3. Implement the management practices.
4. Develop contingency plans to address possible threats.
5. Monitor the effectiveness of management practices.

Source water management options or tools can be broadly classified between regulatory and nonregulatory options. At the local level, the regulatory practices are usually in the form of zoning ordinances, subdivision ordinances, or regulations assigned directly to the protection of groundwater. The USEPA *Handbook for Groundwater and Wellhead Protection* (1994) indicates a number of options for implementation of a source water protection program as tools, including land use practices, regulations or legal measures, and administrative considerations. Of course, a groundwater-monitoring program is necessary to monitor the success of any source water protection program.

Figure 3-2 is an example of the source water protection areas from Broward County, Fla. The county has four tiers for regulation based on travel times from the surface to existing wells. Activities are limited based on these tiers (Tier 4 has no requirements).

Zone 1

This provides for up to a 10-day buffer around the well field. No hazardous chemicals (regulated substances) are permitted within Zone 1.

Broward County Wellfield Map

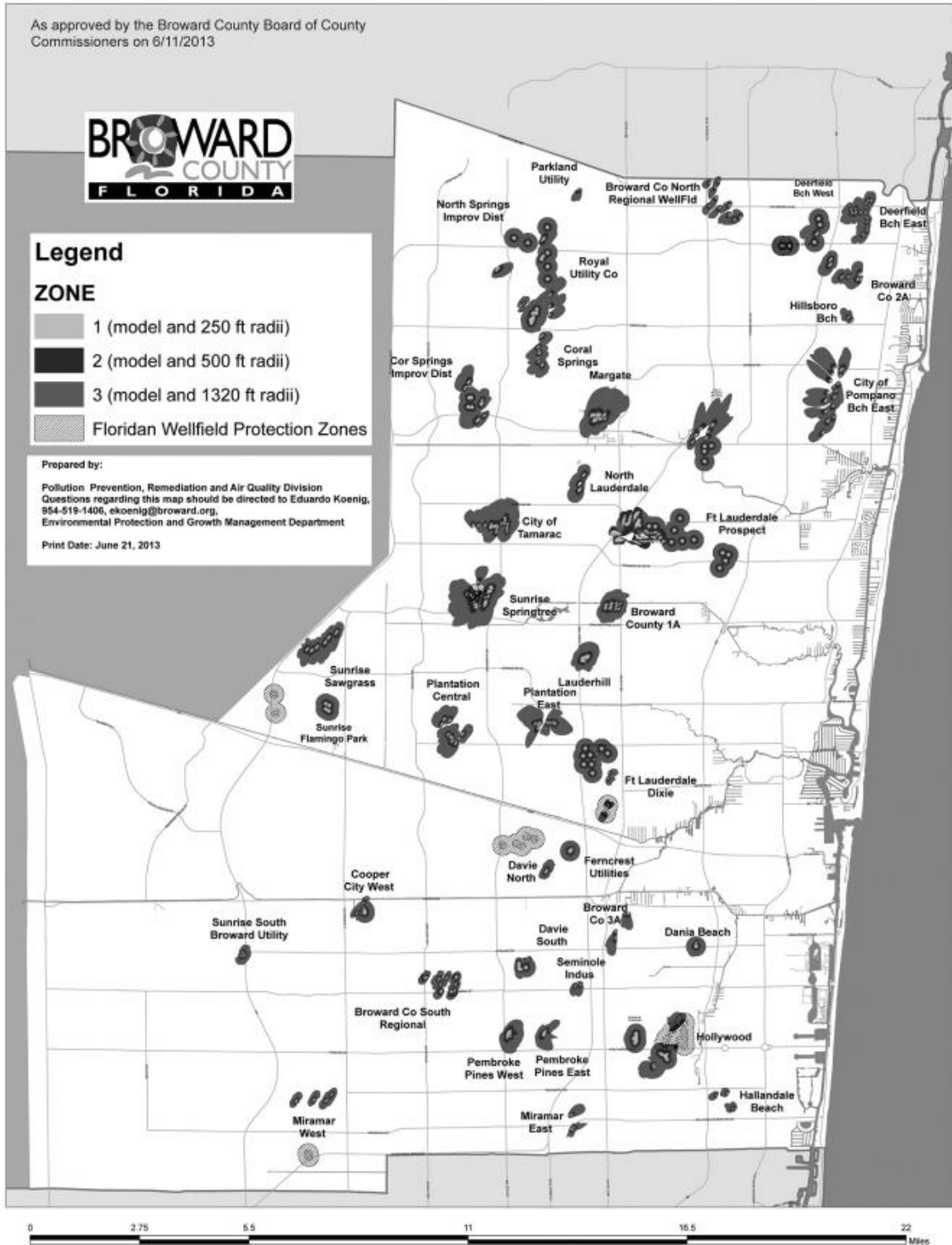

Source: Broward County, Fla.

Figure 3-2 Broward County source water protection zones

Zone 2

This provides up to a 30-day buffer. Businesses are required to be licensed and test the groundwater at their facility for regulated substances they store or use on site.

Zone 3

This provides up to a 210-day buffer. Businesses are required to be licensed and secondary containment is mandated for their stored regulated substances.

In conjunction with source water protection efforts, water systems (municipal utilities, independently owned utilities, and other water management agencies) should identify any groundwater sources they are using that may be directly affected by surface water. The concern is that if there is minimal filtration that occurs between the surface and the water withdrawn for wells, contaminants, especially microbiological constituents, may contaminate the water source. Water sources that meet this criteria are considered groundwater under the direct influence of surface water (GWUDI). If an aquifer is determined to be GWUDI of surface water, and therefore vulnerable to contamination by disease-causing organisms found in surface water, the well water must be treated under the same requirements as a surface water system, requiring mandatory disinfection and filtration.

MANAGEMENT STRATEGIES

The problem with groundwater protection is that aquifers are geographically extensive and as a result often transcend local jurisdictional boundaries. Some aquifers may extend beyond state or provincial control. As a result, the varying institutions create barriers that offer formidable challenges to source water protection. For example, different entities may coexist in aquifers that

- supply public municipal water
- supply private users
- deliver imported water
- recharge the aquifer
- control flooding
- oversee quality
- oversee quantity
- manage irrigation supply
- manage cleanup
- manage biological habitats and species
- dispose of wastes

In developing a source water protection program, water suppliers must involve the various diverse perspectives and interests of the community to be successful.

Source water protection requires cooperative efforts on all governmental levels and between units of government because of the movement of water across jurisdictional boundaries. To resolve water quality management issues associated with water supplies, agreements are normally developed (as arduous as this may be). The creation of agreements to alter the management, institute cleanup, or improve protection of a groundwater aquifer requires negotiation and a regional outlook by each entity. Figure 3-3 illustrates these and other groundwater management factors.

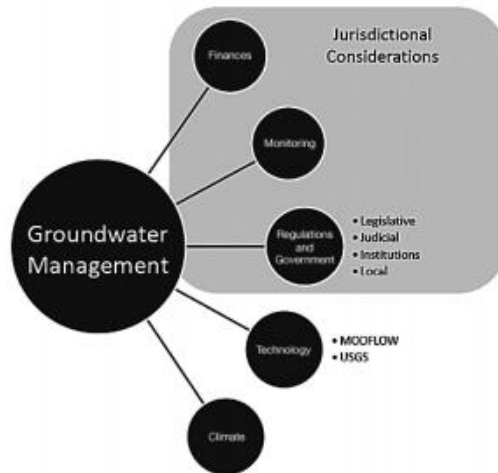

Figure 3-3 Groundwater management factors

The goal in all of these agreements is to create a set of rules that limit the potential for contamination. The best way to prevent contamination is to prevent it from happening in the first place, which means limiting activities that might contaminate an aquifer. As a result, source water protection is the first of the multiple public health protection barriers normally suggested for water agencies.

CONTAMINATED GROUNDWATER MANAGEMENT

Source water protection programs should be responsive to local needs and allow local autonomy, which is important in many governmental jurisdictions and in areas where multi-jurisdictional cooperation is needed. The programs are also where the impact of contamination will impact local decisions.

What contaminants should utilities look for? More than 90,000 synthetic chemicals are in common commercial and industrial use in the United States, a number that continues to grow every year. Few are tested for, yet more than 200 of these chemical substances have been found in groundwater. Others may occur in groundwater where wells are not currently being drilled or investigation has not occurred. Typically, concern does not arise until a contaminant is found in a potable supply. Organic chemicals have become a pervasive contaminant in groundwater supplies. This pollution is more extensively discussed in chapter 8.

What happens when the aquifer is or is likely to become contaminated? When groundwater has been contaminated, a variety of strategies are used. The main strategies are blend, pump and treat, use for nonpotable water, relocate the well, or abandon the supply, with each step down costing more or requiring more new sources of water (Figure 3-4).

The least expensive and most common strategy is blending the contaminated water with another source to meet drinking water standards. Water of differing types of contamination may be blended together to reduce their respective problems to acceptable levels. Sources include

- a cleaner part of the aquifer
- a different aquifer within the aquifer
- another aquifer
- imported supplies

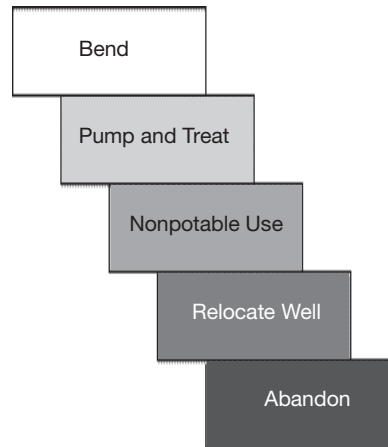

Figure 3-4 Options to address contaminated aquifers

In the pump and treat strategy, groundwater is extracted from an aquifer and treated in aboveground facilities (see chapter 7). In some cases, the groundwater is treated beyond the required level and then blended with nontreated groundwater to produce a more cost-effective, potable supply. Treatment is generally more expensive than blending and may not always be technologically feasible. However, if the cost of water imported to supplement local supplies increases and its availability diminishes, the treatment of lower-quality groundwater can become feasible.

Heavily contaminated groundwater is sometimes used for nonpotable purposes, such as industrial use or landscape and agricultural irrigation. These practices may become obsolete if agricultural land is converted to urban or residential use and the nonpotable distribution system is not extended to other potential users. Reclaimed wastewater (filtered and highly disinfected wastewater) is also being used, as regulations permit, for purposes that do not require direct use as potable water, such as for irrigating golf courses or crops and cooling water for power generation. Additionally, indirect use of reclaimed water to recharge groundwater aquifers for later potable use is being pursued in some arid areas in the western United States. It is also being pursued as a method for salinity control in some coastal areas (see chapter 11).

A contaminated well may be replaced by drilling a new well in a different aquifer or in a more pristine area of the aquifer. Sufficient knowledge of the hydrogeology, as well as the nature and extent of the pollution plumes, is required so that contamination is not spread further or drawn to the new pumping site.

If deemed too costly to treat, a contaminated groundwater basin or aquifer may be abandoned and replaced with imported or alternate supplies. Without active aquifer monitoring and management, later restoration of the aquifer becomes more difficult. Basins and aquifers are not static, as plumes of contamination expand, migrate, and mix. This approach is becoming less viable, especially in arid parts of the country where imported supplies are limited and population growth continues.

REGIONAL GROUNDWATER MANAGEMENT

Of the two major concerns of groundwater management, quantity and quality, the former has traditionally been the reason that brought entities with an interest in water together. Three methods employed to stretch supplies further by expanding locally available supplies are artificial recharge, conjunctive use, and water wheeling. In arid

regions such as the southwestern United States, artificial recharge has been practiced for decades, with conjunctive-use agreements initiated in the 1960s, and water-wheeling arrangements starting in the 1990s.

Artificial Recharge

Artificial recharge augments groundwater supplies by supplementing natural recharge. Surface aquifers percolate stormwater captured from precipitation, imported water, and sometimes recycled water. This concept is discussed more fully in chapter 11.

Conjunctive Use

Groundwater management programs can improve the long-term reliability of water supplies by integrating the use of surface water and groundwater together, or conjunctively. Conjunctive use may be accomplished through either direct or replacement operations.

Direct conjunctive use places imported water into the aquifer, and the water is then pumped as needed. Replacement (or *in-lieu*) conjunctive use is when a water supplier uses imported water instead of pumping its groundwater, leaving the groundwater available in the aquifer for use at a later time. *Seasonal storage* operations recharge an aquifer with imported water during wet times of the year, when surface and imported waters are plentiful, and pump the water out during high-demand months, generally within that same water year. This management strategy results in a seasonal shift, with water typically stored in winter months and pumped during summer months. *Carryover storage* occurs when the recharged water is held for use beyond the next water year, such as for a drought. This process is referred to as *aquifer storage and recovery* and is discussed more fully in chapter 11.

Water Wheeling

Water wheeling uses a water supplier's transportation system for delivery of water not owned or controlled by that agency. Wheeling is a common practice in the energy and communications industries. Some states have enacted legislation regulating wheeling.

For example, the California Water Code requires that water wheeling must not harm any other legal user of water. The cost of wheeling typically recovers costs such as transportation, including capital and operating costs associated with pipelines, reservoirs, and other facilities required to distribute water.

Water Marketing and Water Transfers

Water marketing is the general term encompassing the transfer, lease, or sale of water or water rights. A water transfer is the shift or sale of water from a seller to a buyer. Water transfers can take many forms, each with its own benefits and risks. A *spot transfer* denotes purchase of supplies when needed, such as to offset the effects of a prolonged drought. Under an *option transfer*, the buyer takes a certain amount of water at any time during the life of the agreement, making option payments on an annual basis and making an additional payment in those years in which the water is needed. Buyers in a *core transfer* (or take-and-pay) take a specified amount of water each year and must pay the cost of that water, year in and year out, whether or not the water is needed. This concept is currently applicable only in the western 18 continental United States. Water marketing is increasing in the general public's awareness due to concerns with transferring water from one basin to another, and potential issues that can develop due to decreased surface water and groundwater that is available to residents, natural habitats, and riparian corridors.

GROUNDWATER SUSTAINABILITY

As introduced in chapter 1, sustainability depends on the total water available, the needs of all users in a basin, and how water uses are prioritized.

The key component in planning the use of water supplies is to determine how the hydrologic cycle provides water to the service area (e.g., recharge basin), in what quantities, and with what reliability. The reliability of available water is a risk issue; for example, is precipitation consistent or are there significant fluctuations that disrupt ongoing basin development (Molak 2007). Additionally, due to the variability of groundwater uses and demands over time, each basin has unique characteristics (Bloetscher and Muniz 2008).

Scanlon et al. (2005) identified the need to fully to optimize management of water resources. Most surficial changes decrease available recharge to groundwater. Groundwater recharge is affected by precipitation, actual evapotranspiration (ET), topography, land use, soil type, land cover, aquifer transmissivity, vegetation characteristics, and contributions to recharge along active stream channels (Herrera-Pantoja and Hiscock 2008). In most cases, historical information of the quantity of water that was initially available is limited. While historical water availability in any given basin has already changed as a result of water use practices, the magnitude of the changes is uncertain. In rural areas, increased ET is observed in areas with large-scale irrigation, which then alters regional precipitation patterns (Moore and Rojstaczer 2002; Scanlon et al. 2005). Evidence also indicates that deforestation increases runoff, while decreasing the time of runoff and the amount of time available for infiltration (NCR 2004).

Deforestation is not the only activity that causes changes. As land uses change, raw water quality may change because the recharge supply quality changes (with surface water supplies, runoff may cause rivers to flow faster, increasing sediments and nutrients). Changes in the surface cover will change surface temperatures that can affect ET. Open water bodies have higher ET rates than land. Forest lands are known to maintain cooler temperatures on the surface (with accompanying high evapotranspiration and longer runoff times), while open areas have generally higher temperatures, a phenomenon known as the *heat island effect* (Bloetscher and Muniz 2008).

Growth, development, and zoning strategies of the area associated with the raw water supply are needed. The change in land use from forests to agriculture or urban uses can have significant impacts on runoff characteristics. Hydrologists point out that areas with higher surface imperviousness will accelerate runoff and decrease infiltration. Urban land use increases runoff due to imperviousness from buildings, parking lots, roads, and other improvements that replace forest or grassland cover (Bloetscher and Muniz 2008). Examples of activities that may affect raw water supplies include delivery times of the water through piping installed to reduce flooding and/or supply quantity and development that replaces irrigated agriculture with paving.

Urbanization reduces recharge to groundwater but increases flows to surface reservoirs and streams with potential added nutrients and contaminants. As a result, determining the changes to groundwater availability involves more than calculating the volume of groundwater within any given aquifer: it requires a consideration of recharge, water quality, economics of recovery or of poor quality water, interconnectedness with the hydrologic system, and ecosystem/user demands. Although determining the amount of groundwater available may seem straightforward, it is actually quite complex. Some key difficulties are as follows (Reilly et al. 2009):

“In contrast to rivers and lakes, groundwater systems are hidden from direct observation and measurement:

- The sources of water to groundwater systems and the time required for the effects of withdrawals to propagate through the system and be observed are different for each system,
- The amount of detail (spatial scale) needed to describe the resource depends on the objectives and purpose of the desired information,
- The amount of change in groundwater levels that is important is different for different groundwater systems,
- Not all water pumped is consumed and much of the water pumped is redistributed and changes the groundwater flow system,
- The chemical quality of the water is important in determining its suitability (and thus its availability) for various uses, and
- Groundwater withdrawals can and usually do affect the amount (and quality) of surface water.”

Reilly et al. (2009) outlined the condition of groundwater in the United States, and found that the loss of groundwater supplies is due to over pumping in many areas. Hutson et al. (2004) estimated that the pumping of fresh groundwater in the United States is approximately 83 billion gallons per day. The long-term results from such overpumping could be catastrophic, affecting economic viability of communities and potentially disrupting lives and ecological viability.

As shown in chapter 1 (Figure 1-5), eastern rainfall is much higher than the west. Figure 3-5 shows the difference between rainfall and ET. The -63 to 0 areas are areas where the ET rate is higher than the rainfall, meaning net rainfall (rainfall – ET) for crops and other purposes is not available and high water use is not a sustainable practice. In many of these areas, streamflows are variable and limited, so groundwater is used to ensure water supplies for crops and people. The data in Figure 3-5 are confirmed by aerial views that show extensive irrigation “crop circles” in many areas of high agricultural production and low rainfall. Figure 3-6 shows that many of these areas are water deficit areas. Figure 3-7 shows the amount of water available for recharge throughout the United States. Most areas have very little water available for recharge.

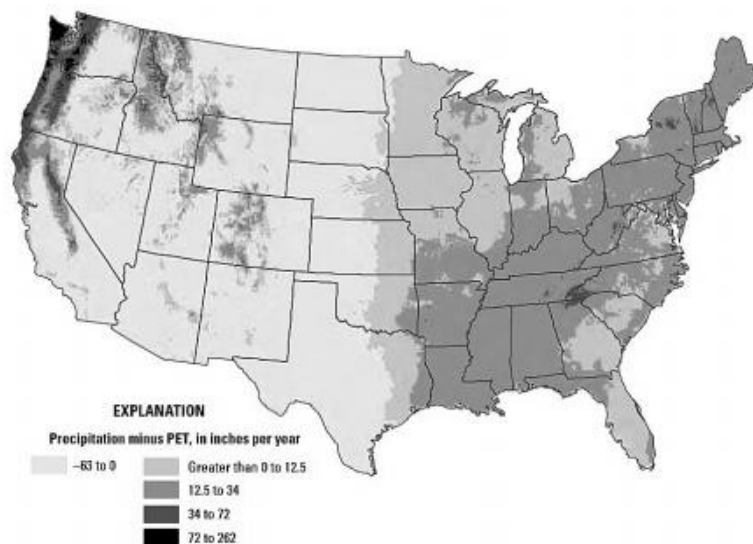

Source: USGS Circular 1323

Figure 3-5 Difference between average annual precipitation and potential ET rates

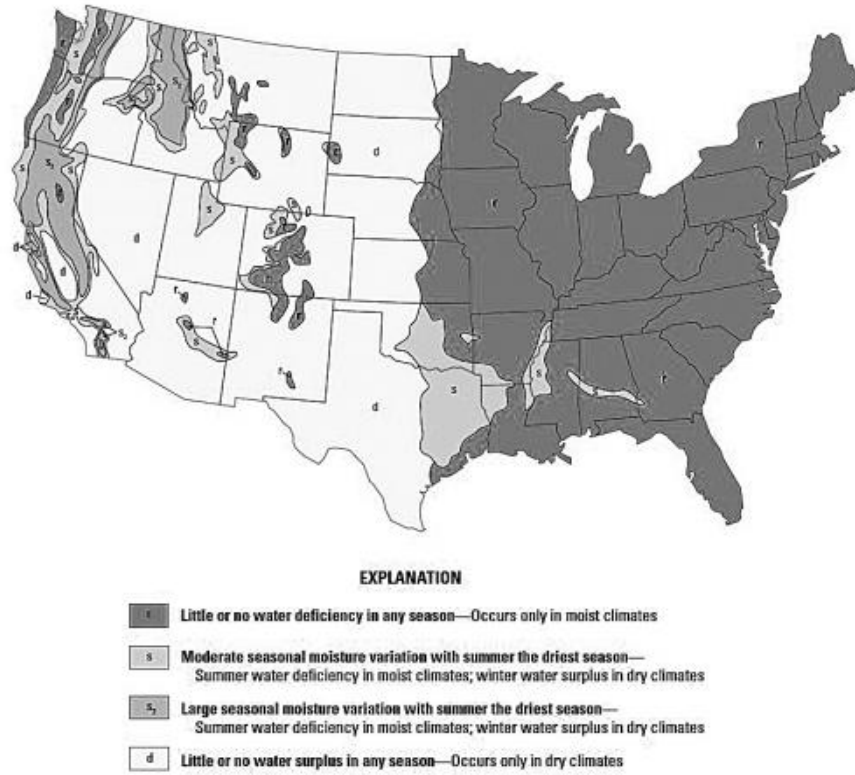

Source: USGS Circular 1323

Figure 3-6 Water deficit areas

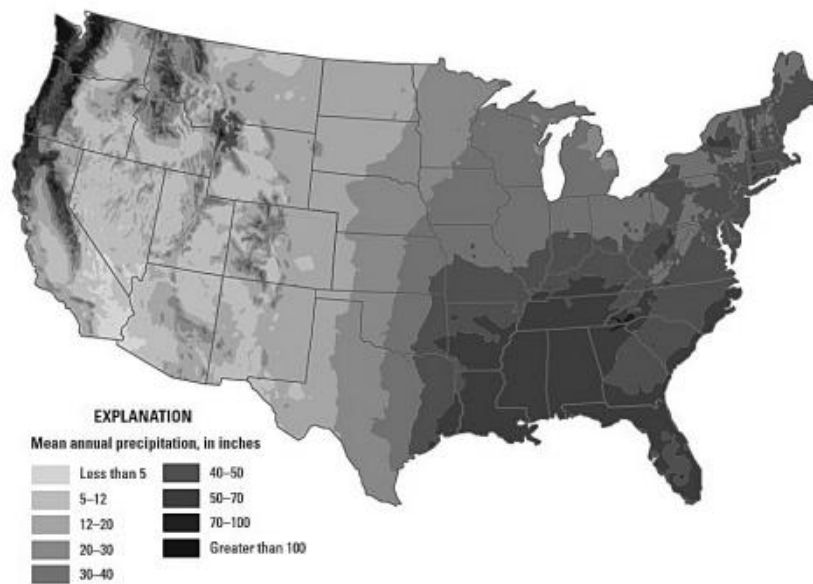

NOTE: most areas are very low

Source: USGS Circular 1323

Figure 3-7 Water available for recharge throughout the United States

The ideal planning and design of well fields should assume that the wells could pump continuously with no permanent drawdowns, meaning that the wells recharge locally. The more common practice is to pump wells that have a significant drawdown for only a few hours each day, allowing an extended period for the aquifer to recover. Even this is difficult as the long-term capacity of an aquifer can be determined by short-term tests and study of the geology of the area. Rarely is a consultant paid to determine that sustainable water supplies are not available. If the amount of recharge is less than what is being pumped, the wells never fully recover regardless how long they rest. Clearly the practice of “resting” wells has not protected many areas from long-term aquifer declines. Horizontal infiltration galleries may be a solution to part of this operational issue.

It is not uncommon to believe that the solution is to drill deeper wells; however, drilling deeper may actually cause more problems, especially if the drilling is in the same exhausted aquifer. Deeper waters generally tend to have poorer water quality as a result of having been in contact with the rock formation longer, dissolving the minerals in the rock into the water. Therefore, while some deep aquifers may be prolific, the quality of water obtained from a well may not be desirable or even usable for drinking water without substantial amounts of treatment. In addition, many deep aquifers are confined and do not recharge significantly locally. The result is the potential for aquifer drawdown accompanied by aquifer mining and land subsidence.

Figure 3-8 combines regional water-level declines and local water-level declines for changes on a national scale. USGS reports the need for a nationwide effort to organize available information on changes in groundwater storage, similar to what was done for the High Plains aquifer (Reilly et al. 2009). The Great Plains states, Texas, and the west are particularly affected. The dark gray regions in Figure 3-8 indicate areas in excess of 500 m² that have water-level decline in excess of 40 ft in at least one *confined* aquifer since predevelopment, or in excess of 25 ft of decline in unconfined aquifers since predevelopment. The confined aquifers recharge at very low rates, meaning that in most cases, these aquifers are being mined (overdrafted). The dots on Figure 3-8 are wells in the USGS National Water Information System database where the measured water-level decline over

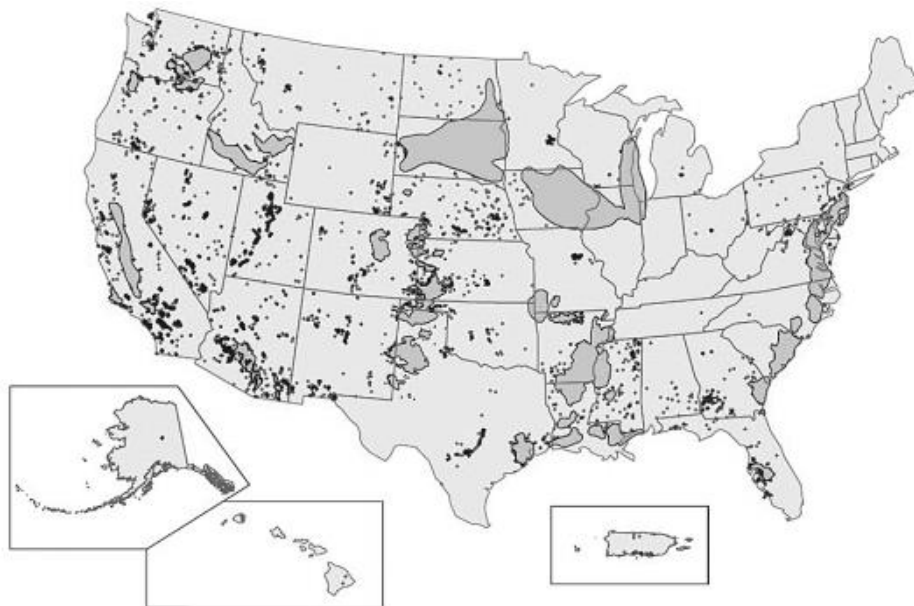

Source: USGS Circular 1323

Figure 3-8 Water-level declines

time is equal to or greater than 40 ft. Confounding the problem is that many aquifer systems cross political boundaries, so careful regulation in one jurisdiction may not be supported by others.

The withdrawal of groundwater may appear to be a loss of the resource in the long term. For example, portions of the Middendorf and Black Creek aquifers in eastern North and South Carolina were virtually drained due to pumpage and no local recharge. As a result the aquifer was mined, meaning that the amount of water withdrawn exceeded the safe yield of the aquifer, or the amount of water that could be withdrawn without reducing the total aquifer water availability (usually withdrawals must be less than potential recharge). In North and South Carolina, the large water utilities converted to using surface water. However, much of the aquifer use in the western states has limited potential for recharge, and surface water systems are not readily available. In parts of the western plains states and Great Basin, the aquifers have dropped hundreds of feet, but with an average of 13–18 in. per year of rainfall, and high evaporation rates throughout the summer, little of this water has potential to recharge the aquifer (Bloetscher and Muniz 2008).

The results of the current evaluation suggest the likelihood of conflicts over water supplies in the near future. To reduce this potential, resolution of water rights, water quality, and other laws should be evaluated. In the absence of willing parties to conclude water rights or withdrawal rights, these cases often go to court, which is time consuming. Identifying critical natural capital requires a systematic analysis and evaluation of whether environmental functions are being used sustainably, the extent of any sustainability gaps, identification of economic and environmental pressures, and monitoring public policies aimed at improving the ecological system. Criteria that can be used include (Elkins 2003):

- Maintenance of human health to avoid negative health impacts
- Avoidance of loss of ecological function
- Economic sustainability—maintenance of economic activities on basis that does not deplete the resource

The objective of effective resource utilization is equivalent to the goal of sustainable project design (Virjee and Gaskin 2005). From a systems perspective, a sustainable society is one that has in place the institutional, social, and informational mechanisms to keep in check the feedback loops that cause exponential population growth and natural capital depletion. A sustainable world is not a rigid one, where population or productivity is held constant. Yet sustainability does require rules, laws, and social constraints that are recognized and adhered to by all (Meadows, 2005). Currently, the desire to grow and develop economically is outweighing the goal of sustainability.

Implicit in the evaluation of these sustainability concepts is the uncertainty and renewability of natural resources and the alternatives thereto. Sustainability should consider what is being sustained and whether it is inclusive enough to account for multiple objectives, otherwise money or resources may be wasted in competition between objectives. (Popp et al. 2001). Included in this view is biodiversity of the ecosystem, although the value of biodiversity may be difficult to measure without understanding the mix and makeup of the ecosystem (Pearce and Moran 1993). As an example, a natural resource stock (such as forests) generates desired human services (such as lumber and recreation; Popp et al. 2001). Depleted ecological stocks cannot be sustained, and conserving natural capital does not always imply absolute protection against depletion.

Distortions of natural cycles of water resources create a problem in the water resource sustainability question (Beck 2005). In such cases, economists try to determine the value of the best alternative and analyze the trade-offs, or costs. For example, if a wilderness area is timbered, will it cease to be a productive fishery? Is this a net positive or negative to the sustainability of the basin? The opportunity cost of the timber alternative may equal the value of the lost fishery.

In summary, the understanding of groundwater has evolved over time. Groundwater, while not necessarily visible, is a key and integral component of the hydrologic cycle. This cycle, and its implications for understanding the future of water, is now introduced to elementary and secondary schools. Future generations will grow and develop in this knowledge as the current generation works toward a future with perhaps less available water, but also more effectively managed water. For the immediate and near-term water issues, most policy discussions about water include water sources—surface water, shallow and deep groundwater, springs, upstream and downstream diversions, etc.—and implications of supply and demand numbers within the context of human and habitat needs. For future sustainability, there must be a balance between population growth, human needs, and limits on available water.

FUTURE GROUNDWATER MANAGEMENT

As discussed in this chapter, groundwater has been and continues to be managed under distinctly different approaches by region, by state versus federal rules, and by traditions. A more integrated management approach in the future is key to having groundwater as a water supply, as a base flow to rivers, and as a fundamental basis for healthy spring systems. Integrated management is projected to become part of utility management plans in the future as utilities grow and develop their raw water sources, as well as bring in alternative water sources. Those utilities that invest in their future now will be best placed to weather the uncertainties of future water supply and demands.

REFERENCES

- Asano, T. 1985. *Artificial Recharge of Groundwater*. Stoneham, Mass.: Butterworth Publishers.
- Barwick, R.S., D.A. Levy, G.F. Craun, M.J. Beach, and R.L. Calderon. 2000. Surveillance for waterborne-disease outbreaks—United States, 1997–1998. *Morbidity and Mortality Weekly Report*, 49(SS04):1–35.
- Beck, M.B. 2005. “Vulnerability of Water Quality in Intensively Developing Urban Watersheds,” *Environmental Modeling and Software*, Vol. 20, pp. 381–400.
- Bloetscher, F. 2009. Climate Change Impacts on Florida Water Supplies. *AWWA Annual Conference*. Denver, Colo.: American Water Works Association.
- Bloetscher, F. 2011. *Utility Management for Water and Wastewater Operators*. Denver, Colo.: American Water Works Association.
- Bloetscher, F. and A. Muniz. 2008. Water Supply in South Florida—The New Limitations. *Sustainable Water Sources (Reno) Conference*. Denver, Colo.: American Water Works Association.
- Bloetscher, F., G.M. Gerhardt, and A.E. Dodd. 1997. Bacterial Issues in Raw Water Treatment. *Florida Water Resource Conference*. Orlando, Fla.
- Blackburn, B.G., G.F. Craun, J.S. Yoder, V. Hill, R.L. Calderon, N. Chen, S.H. Lee, D.A. Levy, and M.J. Beach. 2004. Surveillance for waterborne-disease outbreaks associated with drinking water—United States, 2001–2002. *Morbidity and Mortality Weekly Report*, 53(SS08):23–45.
- Elkins, P. 2003. Identifying Critical Natural Capital—Conclusions about Critical Natural Capital. *Ecological Economics*, Vol. 44, pp. 277–292.
- Groundwater Foundation. 1995. *A Community Guide to Groundwater Guardian*. Lincoln, Neb.: Groundwater Foundation.
- Herrera-Pantoja, M. and K.M. Hiscock, 2008. The effects of climate change on potential groundwater withdrawal in Great Britain. *Hydrologic Processes* 2(1):73–86.
- Hutson, S.S., N.L. Barber, J.F. Kenny, K.S. Linsey, D.S. Lumia, and M.A. Maupin. 2004. Estimated use of water in the United States in 2000: *U.S. Geological Survey Circular* 1268. Reston, Va.: USGS.
- Keswick, B., C.P. Gerba, S.I. Secor, and I. Cech. 1982. Survival of Enteric Viruses and Indicator Bacteria in Groundwater. *Journ. of Environmental Science Health*, A17(6):903–912.

- Lee, S.H., D.A. Levy, G.F. Craun, M.J. Beach, and R.L. Calderon. 2002. Surveillance for waterborne-disease outbreaks—United States, 1999–2000. *Morbidity and Mortality Weekly Report*, 51(SS08): 1–28.
- Liang, J.L., E.J. Dziuban, G.F. Craun, V. Hill, M.R. Moore, R.J. Gelting, R.L. Calderon, M.J. Beach, and S.L. Roy. 2006. Surveillance for waterborne disease and outbreaks associated with drinking water and water not intended for drinking—United States, 2003–2004. *Morbidity and Mortality Weekly Report*, 55(SS12): 31–58.
- Meadows, D. and J. Randers. 2005. *Limits to Growth: The 30 Year Update*. White River Junction, Vt.: Chelsea Green Publishing Co.
- Molak, V. 1997. *Fundamentals of Risk Analysis and Management*. Boca Raton, Fla.: Lewis Publishers.
- Moore N. and S. Rojstaczer. 2002. Irrigation's influence on precipitation: Texas High Plains, U.S.A. *Geophysical Research Letters*, 29, 2-1–2-4.
- Nace, R.L. 1960. Water management, agriculture, and ground-water supplies. *U.S. Geological Survey Circular* 415. Reston, Va.: USGS.
- Pearce, D. and D. Moran. 1994. *The Economic Value of Diversity*. London: IUCN, Earthscan Publications Ltd.
- Popp, J., D. Hoag, and D.E. Hyatt. 2001. Sustainability Indices with Multiple Objectives. *Ecological Indicators*, Vol. 1, pp. 37–47.
- National Research Council (NRC). 2004. *Assigning Economic Value to Natural Resources*. Washington, DC.: National Academy Press.
- Reilly, T.E., K.F. Dennehy, W.M. Alley, and W.L. Cunningham. 2009. Ground-Water Availability in the United States, *USGS Circular* 1323. Reston, Va.: USGS.
- Scanlon, B.R., R.C. Reedy, D.A. Stonestrom, D.E. Prudic, and K.F. Dennehy. 2005. Impact of land use and land cover change on groundwater recharge and quality in the southwestern US. *Global Change Biology* 11, 1577–1593.
- US Environmental Protection Agency (USEPA). 1991. *Protecting the Nation's Groundwater: EPA's Strategy for the 1990s*. Washington, D.C.: USEPA.
- USEPA. 1994. *Handbook for Groundwater and Wellhead Protection*. Washington, D.C.: USEPA.
- USEPA. 1995. *A Guide to Wellhead Protection*. Washington, D.C.: USEPA.
- Virjee, K. and S. Gaskin. 2005. Fuzzy Cost Recovery in Planning for Sustainable Water Supply Systems in Developing Countries. *Energy*, Vol. 30, pp. 1329–1341.
- Yates, M.V., C.P. Gerba, and L.M. Kelley. 1985. Virus Resistance in Groundwater. *Applied and Environmental Microbiology*. 49(4):778–781.
- Yoder, J., V. Roberts, G.F. Craun, V. Hill, L. Hicks, N.T. Alexander, V. Radke, R.L. Calderon, M.C. Hlavsa, M.J. Beach, and S.L. Roy. 2008. Surveillance for waterborne disease and outbreaks associated with drinking water and water not intended for drinking—United States, 2005–2006. *Morbidity and Mortality Weekly Report*, 57 (SS09): 39–62.

Quantitative Evaluation of Wells

After a qualitative evaluation of a potential groundwater source has confirmed the presence of water-bearing materials, it is necessary to determine how much water can be withdrawn. The basic aquifer parameters that must be evaluated are transmissivity and storage coefficient. What these parameters are and how they are measured is discussed in the first part of this chapter. This chapter also covers well field design, well losses, and radial well yield, and groundwater modeling methods.

AQUIFER PARAMETERS

The most significant aquifer parameters are porosity, transmissivity, specific yield and specific retention, hydraulic head, and gradient. Porosity, specific yield, and specific retention describe the rock formation and quantities of water existing in the formation. Head and gradient determine how water moves through the formation and represent the mechanics of horizontal and vertical recharge to a well being pumped. Head and gradient are also used to analyze the transport of pollutants that may migrate to a well. Transmissivity indicates how easily water will move in the formation and is perhaps the most commonly used term by hydrogeologists. Figure 4-1 is a theoretical cube of sand, limestone, or other formation that stores or allows water to flow through it. From this diagram, groundwater flow can be easily understood.

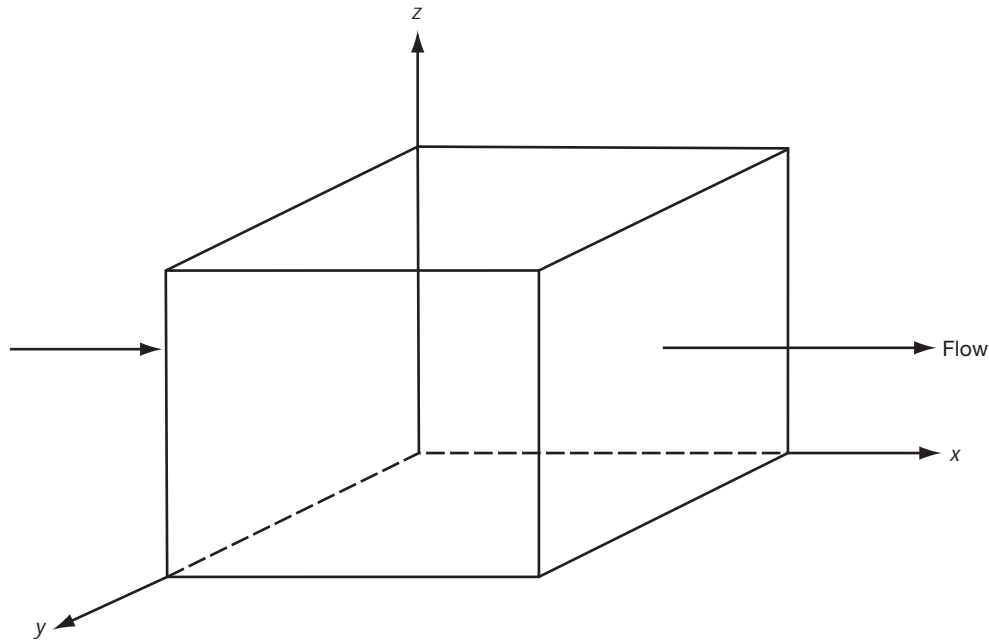

Figure 4-1 Theoretical cube

The focus of much of this chapter is on the math associated with wells and well fields. It may be rigorous for some, although minimal calculus is involved, and the resulting equations can be used for hand calculations or entered into spreadsheet programs.

Porosity

The ratio of openings (voids) to the total volume of a soil, sediment, or rock is referred to as *porosity*. Porosity is expressed either as a decimal fraction or as a percentage as shown in Figure 4-2. Thus,

$$n = \frac{V_t - V_s}{V_t} = \frac{V_v}{V_t} \quad (\text{Eq. 4-1})$$

Where:

- n = porosity, as a decimal fraction
- V_t = the total volume of a soil or rock sample
- V_s = the volume of solids in the sample
- V_v = the volume of openings (voids)

If the porosity determined using Eq. 4-1 is multiplied by 100, the result is porosity expressed as a percentage.

Soils are among the most porous of natural materials because soil particles tend to form loose clumps and because of the presence of root holes and animal burrows. The porosity of unconsolidated sand and gravel depends on the range in grain size “sorting” and on the shape of the rock particles but not on their size. Fine-grained materials tend to be better sorted and have the highest porosity values. Table 4-1 lists selected values of porosity.

Porosity values determine the maximum amount of water that a rock can hold when it is saturated. Only a part of this water, however, is available to supply a well or a spring.

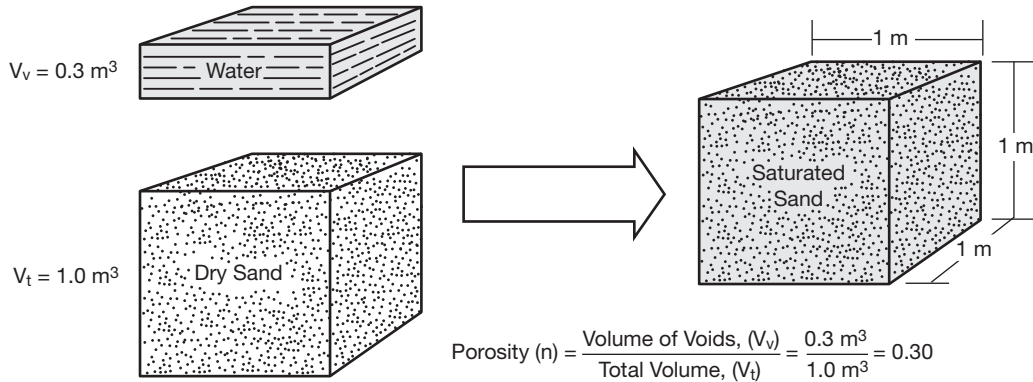

Figure 4-2 Definition of porosity

Specific Yield and Specific Retention

Hydrologists divide groundwater into the portion that will drain under the influence of gravity, which is called *specific yield*, and the portion that is retained as a film on rock surfaces and in very small openings, which is called *specific retention*. The physical forces that control specific retention are the same forces controlling the thickness and moisture content of the capillary fringe as depicted in Figure 4-3. Thus,

$$n = S_y + S_r \tag{Eq 4-2}$$

$$S_y = \frac{V_d}{V_t} \text{ and } S_r = \frac{V_r}{V_t} \tag{Eq. 4-3}$$

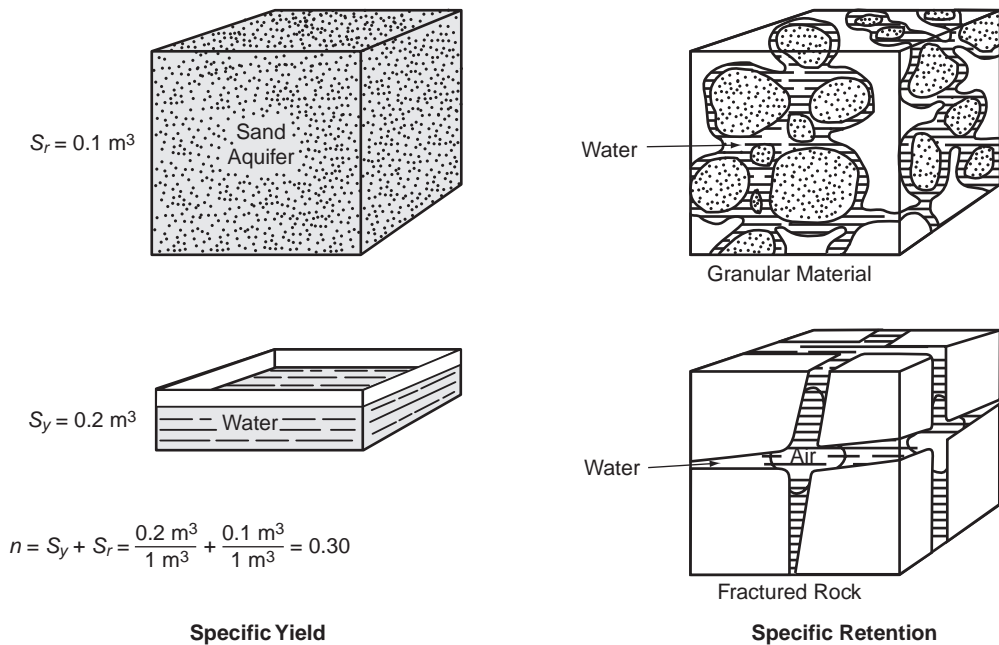

Figure 4-3 Definition of specific yield and specific retention

Where:

- n = porosity
- S_y = specific yield
- S_r = specific retention
- V_d = the volume of water that drains from a total volume, V_t
- V_r = the volume of water retained in a total volume, V_t
- V_t = total volume of a soil or rock sample

Table 4-1 lists selected values of porosity, specific yield, and specific retention.

Hydraulic Head and Gradient

The depth to the water table affects the development of water supplies from unconfined aquifers. Where the water table is shallow, the land may become waterlogged during wet weather and unsuitable for residential and other uses. Where the water table is at great depth, the cost of constructing wells and pumping water for domestic needs may be prohibitively expensive.

The highest head occurs at points of aquifer recharge. The position and the slope of the water table (or of the potentiometric surface of a confined aquifer) are determined by measuring the position of the water level in wells from a fixed measuring point. The position of the water table at each well must be determined relative to a datum plane that is common to all the wells. The datum plane most widely used is the National Geodetic Vertical Datum of 1929, also commonly referred to as *mean sea level*. A newer vertical datum is NAVD88 (North American Vertical Datum of 1988). Sea level is not the same on these two datum and the appropriate correction factors must be used.

Total head. The depth to water in a nonflowing well is subtracted from the elevation of the measuring point to determine the total head at the well. Total head, as defined in fluid mechanics, is the sum of elevation head, pressure head, and velocity head. Because groundwater moves relatively slowly, velocity head can be ignored. Therefore, the total head at an observation well involves only two components: elevation head and pressure head. Groundwater moves in the direction of decreasing total head, which may or may not be in the direction of decreasing pressure head. This is part of the Bernoulli equation in fluid mechanics.

The equation for total head h_t is

$$h_t = z + h_p \quad (\text{Eq. 4-4})$$

Table 4-1 Selected values* of porosity, specific yield, and specific retention

Material	Porosity	Specific Yield	Specific Retention
Soil	55	40	15
Clay	50	2	48
Sand	25	22	3
Gravel	20	19	1
Limestone	20	18	2
Sandstone (semiconsolidated)	11	6	5
Granite	0.1	0.09	0.01
Basalt (young)	11	8	3

*Values are given in percent by volume.

Where:

z = elevation head, the distance from the datum plane to the point where the pressure head h_p is determined.

Hydraulic gradient. All other factors being constant, the rate of groundwater movement depends on the hydraulic gradient. The hydraulic gradient is the change in head per unit of distance in a given direction. If the direction is not specified, it is in the direction in which the maximum rate of decrease in head occurs.

As an example, if the movement of groundwater is in the plane shown in Figure 4-4, that is, if it moves from well 1 to well 2, the hydraulic gradient can be calculated from the information given on the drawing. The hydraulic gradient is calculated by dividing the head loss between two wells (h_L) by the horizontal distance between them (L). In other words, water moves down gradient. For example, using the measurements given in Figure 4-4, the hydraulic gradient can be expressed as

$$\frac{h_L}{L} = \frac{(100 \text{ m} - 15 \text{ m})}{780 \text{ m}} = \frac{85 \text{ m}}{780 \text{ m}} \tag{Eq. 4-5}$$

When the hydraulic gradient is expressed in consistent units, as it is in the above example in which both the numerator and the denominator are in meters, any other consistent units of length can be substituted without changing the value of the gradient. Thus, a gradient of 5 ft/780 ft is the same as a gradient of 5 m/780 m. Hydraulic gradients are often in inconsistent units, such as meters per kilometer or feet per mile. A gradient of 5 m/780 m can be converted to meters per kilometer as follows:

$$\left(\frac{5 \text{ m}}{780 \text{ m}}\right) \times \left(\frac{1,000 \text{ m}}{\text{km}}\right) = 6.4 \text{ m/km}$$

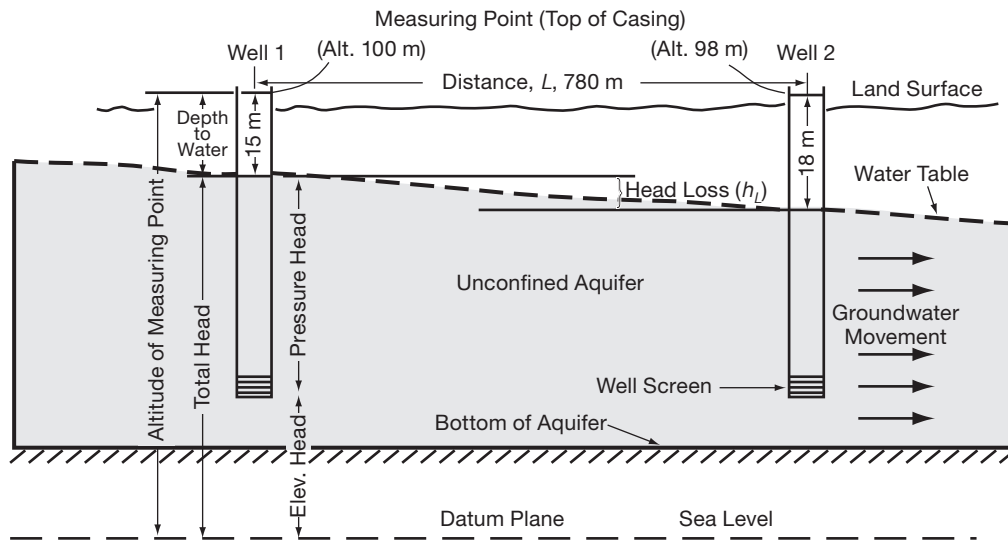

Figure 4-4 Definition of heads and gradients

Calculating groundwater movement and hydraulic gradient. Both the direction of groundwater movement and the hydraulic gradient can be determined if the following data are available for three wells located in any triangular arrangement, such as that shown in Figure 4-5. These data are

- the relative geographic position of the wells
- the distance between the wells
- the total head at each well

Steps for determining direction of groundwater movement and hydraulic gradient are outlined below and illustrated in Figure 4-6.

1. Identify the well that has the intermediate water level, that is, neither the highest head nor the lowest head.
2. Calculate the position between the well having the highest head and the well having the lowest head at which the head is the same as that in the intermediate well.
3. Draw a straight line between the intermediate well and the point identified in step 2 as being between the well having the highest head and that having the lowest head. This line represents a segment of the water-level contour along which the total head is the same as that in the intermediate well.
4. Draw a line perpendicular to the water-level contour and through either the well with the highest head or the well with the lowest head. This line parallels the direction of groundwater movement.
5. Divide the difference between the head of the well and that of the contour by the distance between the well and the contour. The result is the hydraulic gradient.

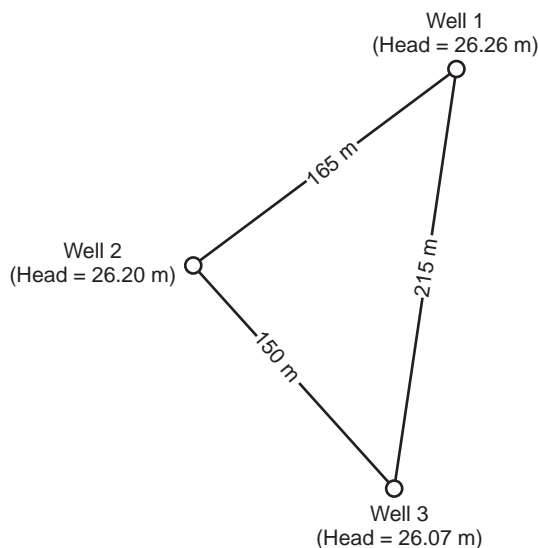

Figure 4-5 Example well location to be used in determining direction of groundwater movement and hydraulic gradient

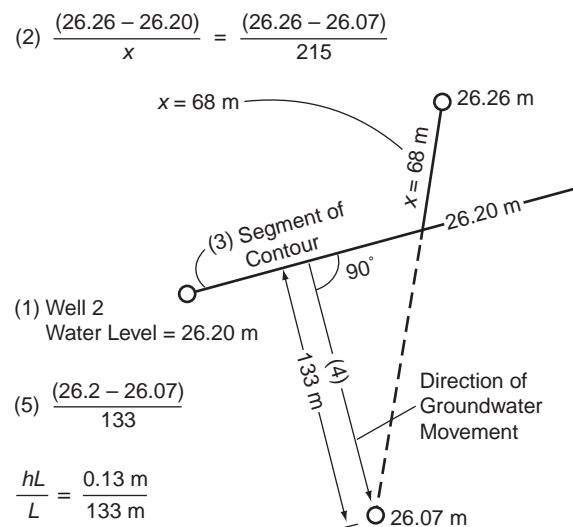

Figure 4-6 Steps in determining direction of groundwater movement and hydraulic gradient

Hydraulic Conductivity

The factors controlling groundwater movement were first expressed by Henry Darcy, a French engineer, in 1856. Darcy's law is as follows:

$$Q = KA \left(\frac{dh}{dl} \right) \quad (\text{Eq. 4-6})$$

Where:

- Q = the quantity of water per unit of time
- K = the hydraulic conductivity
- A = the cross-sectional area, at a right angle to the flow direction, through which the flow occurs
- dh/dl = the hydraulic gradient

Unlike rivers and streams, groundwater tends to move relatively slowly, often measured in feet per day or year. Because of this slow movement, groundwater flow is said to be laminar; that is, water particles tend to follow discrete streamlines and not to mix with particles in adjacent streamlines. As a result, the quantity of water Q is directly proportional to the hydraulic gradient, dh/dl .*

If Eq. 4-6 is rearranged to solve for K , the units of hydraulic conductivity are determined as follows:

$$K = \frac{Qdl}{Adh} = \frac{(\text{m}^3/\text{d})(\text{m})}{(\text{m}^2)(\text{m})} = \frac{\text{m}}{\text{d}} \quad (\text{Eq. 4-7})$$

Thus, the units of hydraulic conductivity are those of velocity (or distance divided by time). In Eq. 4-7, however, the factors involved in the definition of hydraulic conductivity include the volume of water Q that will move in a unit of time (commonly, one day) under a unit hydraulic gradient (such as a meter per kilometer) through a unit area (such as a square meter). These factors are illustrated in Figure 4-7. Expressing hydraulic conductivity in terms of a unit gradient rather than an actual gradient at some place in an aquifer allows values of hydraulic conductivity for different rocks to be compared.

Hydraulic conductivity in rock. The hydraulic conductivity of rocks ranges through 12 orders of magnitude (Figure 4-8). Hydraulic conductivity not only varies by type of rock but is also typically different from place to place in the same rock and in close proximity. If the hydraulic conductivity is essentially the same throughout an area, the aquifer is homogeneous. If the hydraulic conductivity differs from one part of the aquifer to another, the aquifer is heterogeneous. Aquifers are almost always heterogeneous, just to a greater or lesser degree.

Hydraulic conductivity may also vary by direction at any place in an aquifer. If the hydraulic conductivity is essentially the same in all directions, the aquifer is isotropic. If it varies by direction, such as differences between conductivity in the vertical and horizontal directions, the aquifer is anisotropic. Rock aquifers and valley deposit aquifers are typically anisotropic.

* Where hydraulic gradient is discussed as an independent entity, as it is in the previous subsection "Hydraulic Head and Gradient," it is shown symbolically as h_i/L and is referred to as *head loss per unit of distance*. Where hydraulic gradient appears as one of the factors in an equation, as it does in Eq 4-6, it is shown symbolically as dh/dl to be consistent with other groundwater literature. The gradient dh/dl indicates that the unit distance is reduced to as small a value as one can imagine, in accordance with the concepts of differential calculus.

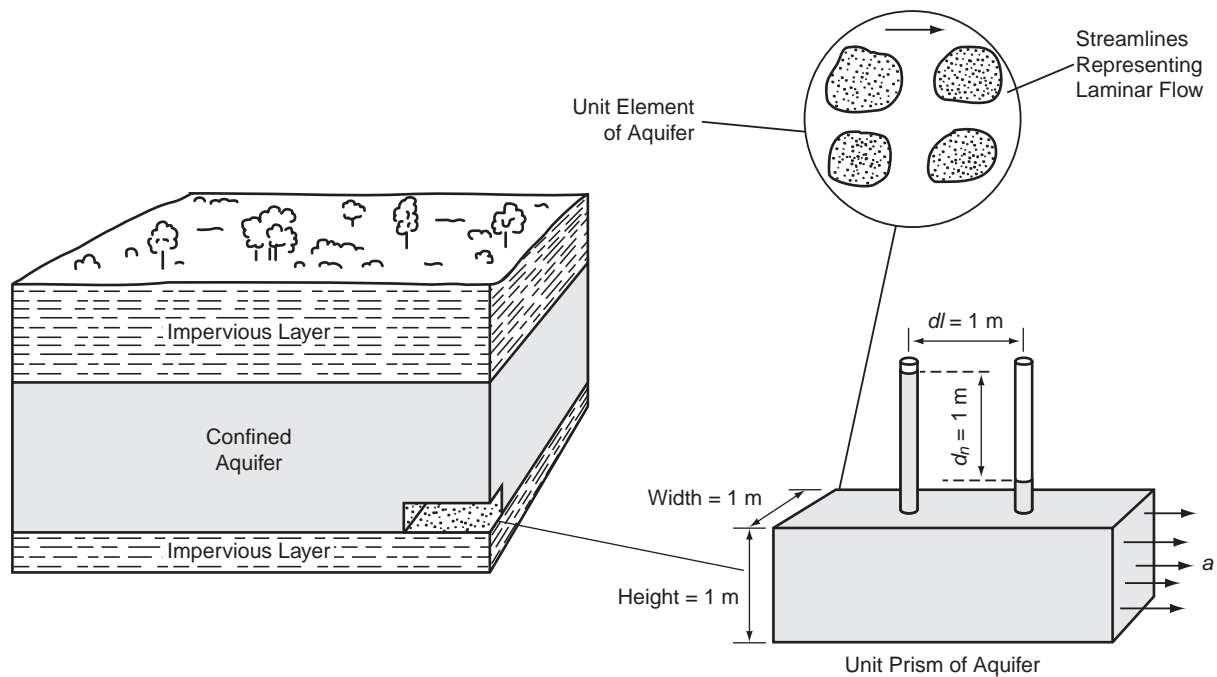

Figure 4-7 Definition of hydraulic conductivity

Although it is convenient in many mathematical analyses of groundwater flow to assume that aquifers are both homogeneous and isotropic, such aquifers are rare, if they exist at all. Hydraulic conductivity in most rocks and especially in unconsolidated deposits and in flat-lying consolidated sedimentary rocks is larger in the horizontal direction than in the vertical direction.

Hydraulic conductivity replaces the term *field coefficient of permeability* and should be used to refer to the water-transmitting characteristic of material in quantitative terms. However, the qualitative terms *permeable* and *impermeable* material are still commonly used.

Capillarity and Unsaturated Flow

Most recharge of groundwater systems occurs during the percolation of water across the unsaturated zone. Both gravitational and capillary forces control the movement of this water.

Capillarity results from the mutual attraction (cohesion) between water molecules and the molecular attraction (adhesion) between water and different solid materials. Most pores in granular materials are of capillary size. Water is pulled upward into a capillary fringe above the water table to a height h_c above the water level. This action is the same as water pulled up into a column of sand whose lower end is immersed in water as Figure 4-9 and Table 4-2 show. The rise of water in the capillary fringe is inversely related to the capillary diameter (Figure 4-9).

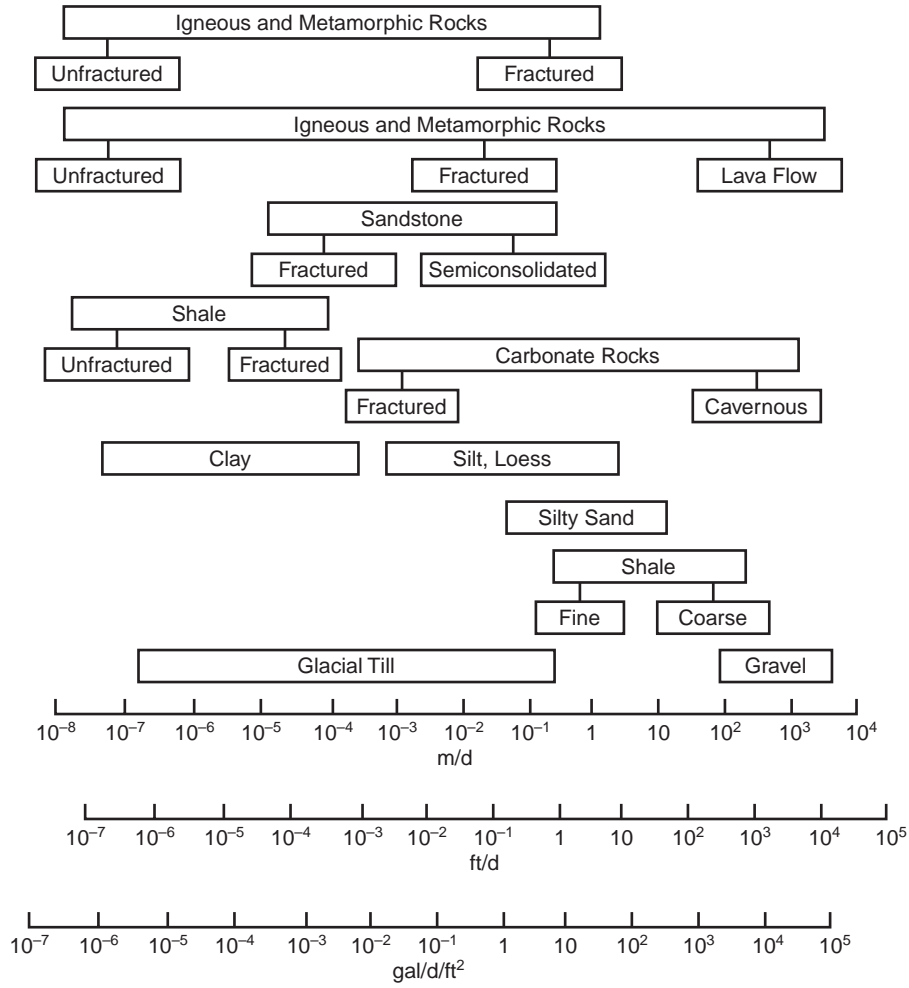

Figure 4-8 Hydraulic conductivity of selected rocks

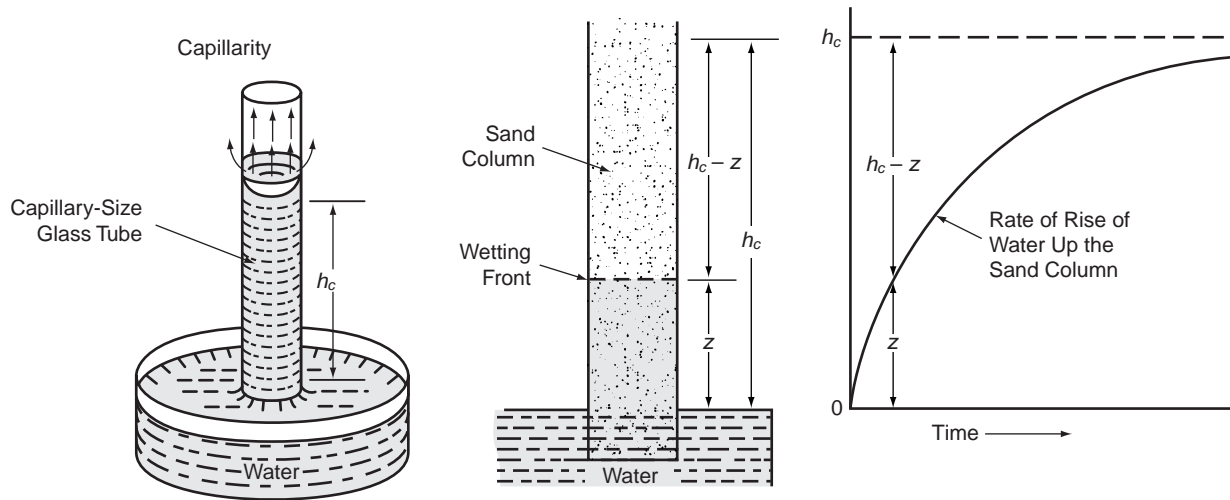

Figure 4-9 Definition of capillarity and unsaturated flow

Table 4-2 Approximate height of capillary rise h_c in granular materials

Material	Rise, in.
Sand	—
Coarse	5
Medium	10
Fine	15
Silt	40

A steady-state* flow of water in the unsaturated zone can be determined using a modified form of Darcy's law (Eq. 4-6). Steady-state unsaturated flow Q is proportional to the effective hydraulic conductivity K_e , the cross-sectional area A through which the flow occurs, and gradients due to both capillary forces and gravitational forces. Thus:

$$Q = K_e A \left(\frac{h_c - z}{z} \right) \pm \left(\frac{dh}{dl} \right) \quad (\text{Eq. 4-8})$$

Where:

Q = the quantity of water

K_e = the hydraulic conductivity under the degree of saturation existing in the unsaturated zone

A = the cross-sectional area through which flow occurs

h_c = height above the water table

z = elevation head

$(h_c - z)/z$ = the gradient due to capillary (surface tension) forces

dh/dl = the gradient due to gravity

The plus/minus sign accounts for the direction of movement: plus for downward and minus for upward. For movement in a vertical direction, either up or down, the gradient due to gravity is $1/l$, or 1. For lateral (horizontal) movement in the unsaturated zone, the term for the gravitational gradient can be eliminated.

The capillary gradient at any time depends on the length of the water column z supported by capillarity in relation to the maximum possible height of capillary rise h_c (Figure 4-9). For example, if the lower end of a sand column is suddenly submerged in water, the capillary gradient is at a maximum, and the rate of rise of water is fastest. As the wetting front advances up the column, the capillary gradient declines, and the rate of rise decreases.

The capillary gradient can be determined from tensiometer measurements of hydraulic pressures. To determine the gradient, the negative pressure h_p must be measured at two levels in the unsaturated zone, as Figure 4-10 shows. Equation 4-4 illustrates that elevation head z is the distance from the datum plane to the point where the pressure head h_p is determined. In this case, Figure 4-10 shows that the elevation head is measured as the elevation of a tensiometer, denoted as z_t . Thus, restating Eq. 4-4, the equation for total head h_t is

$$h_t = z_t + h_p \quad (\text{Eq. 4-9})$$

* Steady state in this context refers to a condition in which the moisture content remains constant, as it would, for example, beneath a waste-disposal pond whose bottom is separated from the water table by an unsaturated zone.

Where:

- z_t = the elevation of a tensiometer
- h_p = pressure head

Substituting values in Eq. 4-4 for tensiometer number 1, the following is obtained:

$$h_t = 32 + (-1) = 32 - 1 = 31 \text{ m} \tag{Eq. 4-10}$$

The total head at tensiometer number 2 is 26 m. The vertical distance between the tensiometers is 32 m minus 28 m, or 4 m. Because the combined gravitational and capillary hydraulic gradient equals the head loss divided by the distance between tensiometers, the gradient is

$$\frac{h_L}{L} = \frac{h_t(1) - h_t(2)}{z(1) - z(2)} = \frac{31 - 26}{32 - 28} = \frac{5 \text{ m}}{4 \text{ m}} = 1.25 \text{ m/m} \tag{Eq. 4-11}$$

This gradient includes both the gravitational gradient dh/dl and the capillary gradient $(h_c - z)/z$. Because the head in tensiometer number 1 exceeds that in tensiometer number 2, the flow is vertically downward and the gravitational gradient is 1/1, or 1. Therefore, the capillary gradient is 0.25 m/m $((1.25 - 1.00)/1.00)$.

The effective hydraulic conductivity K_e is the hydraulic conductivity of material that is not completely saturated. It is less than the (saturated) hydraulic conductivity K_s for the material. Figure 4-11 shows the relation between degree of saturation and the ratio of saturated and unsaturated hydraulic conductivity for coarse sand. The K_s of coarse sand is about 60 m/d.

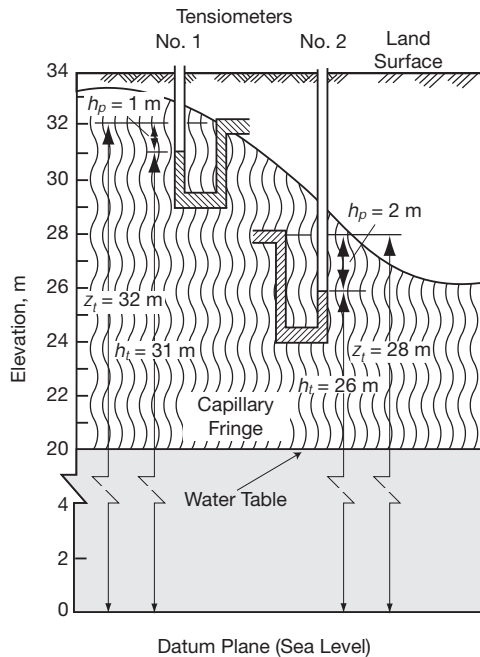

Figure 4-10 Determining capillary gradient from tensiometer measurements of hydraulic pressures

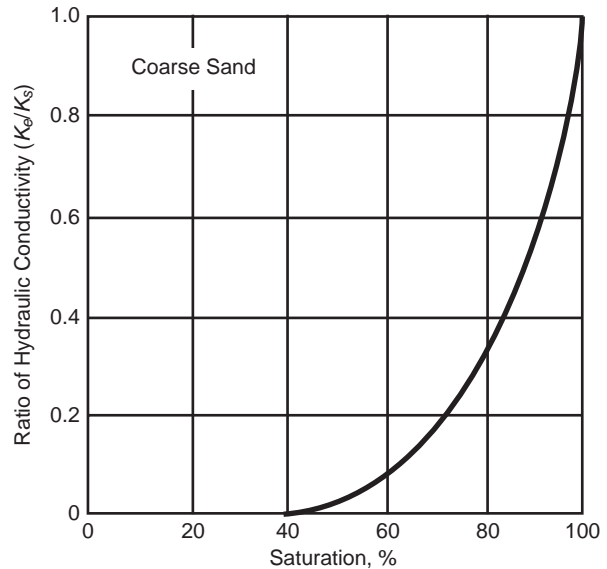

Figure 4-11 Relation between degree of saturation and the ratio of saturated and unsaturated hydraulic conductivity for coarse sand

Transmissivity

The capacity of an aquifer to transmit water of the prevailing kinematic viscosity is its transmissivity. The transmissivity T of an aquifer is equal to the hydraulic conductivity of the aquifer multiplied by the saturated thickness of the aquifer. Thus,

$$T = Kb \quad (\text{Eq. 4-12})$$

Where:

- T = transmissivity
- K = hydraulic conductivity
- b = aquifer thickness

As is the case with hydraulic conductivity, transmissivity is also defined in terms of a unit hydraulic gradient.

Recalling Darcy's Law (Eq. 4-6)

$$Q = KA \left(\frac{dh}{dl} \right)$$

if the area A is expressed as aquifer thickness (b) times aquifer width (w); then

$$Q = Kbw \left(\frac{dh}{dl} \right) \quad (\text{Eq. 4-13})$$

Next, substituting transmissivity T for Kb

$$Q = Tw \left(\frac{dh}{dl} \right) \quad (\text{Eq. 4-14})$$

Eq. 4-14 modified to determine the quantity of water Q moving through a large width W of an aquifer is

$$Q = TW \left(\frac{dh}{dl} \right) \quad (\text{Eq. 4-15})$$

If Eq. 4-15 is applied to Figure 4-12, the quantity of water flowing from the right side of the drawing can be calculated by using the values

$$T = Kb = \frac{50 \text{ m}}{\text{d}} \times 100 \text{ m} = 5,000 \text{ m}^2/\text{d} \quad (\text{Eq. 4-16})$$

$$Q = TW \left(\frac{dh}{dl} \right) = \frac{5,000 \text{ m}^2}{\text{d}} \times 1,000 \text{ m} \times \frac{1 \text{ m}}{1,000 \text{ m}} = 5,000 \text{ m}^3/\text{d} \quad (\text{Eq. 4-17})$$

Eq. 4-17 is also used to calculate transmissivity, where the quantity of water Q discharging from a known width of aquifer can be determined as, for example, with streamflow measurements. Rearranging terms, the following is obtained

$$T = \frac{Q}{W} \left(\frac{dl}{dh} \right) \quad (\text{Eq. 4-18})$$

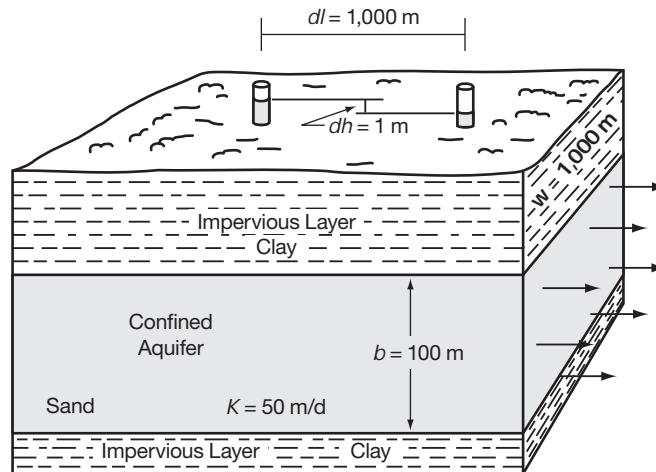

Figure 4-12 Definition of transmissivity

The units of transmissivity, as the preceding equation demonstrates, are

$$T = \frac{(\text{m}^3/\text{d})(\text{m})}{(\text{m})(\text{m})} = \frac{\text{m}^2}{\text{d}} \quad (\text{Eq. 4-19})$$

Calculating transmissivity. Figure 4-13 illustrates the hydrologic case that permits calculation of transmissivity through the use of stream discharge, although T is much more commonly calculated from hydrogeologic analysis of aquifer tests (see following). The calculation can be made only during dry-weather (baseflow) periods, when all water in the stream is derived from groundwater discharge. For the purpose of this example, the following values are assumed:

- Average daily flow at stream-gauging station A: 2,485 m³/d
- Average daily flow at stream-gauging station B: 2,355 m³/d
- Increase in flow due to groundwater discharge: 0.130 m³/d
- Total daily groundwater discharge to stream: 11,232 m³/d
- Discharge from half of aquifer (one side of the stream): 5,616 m³/d
- Average thickness of aquifer b : 50 m
- Distance W between stations A and B: 5,000 m
- Looking at the figure, notice that the cross sectional area, (bW), remains perpendicular to the idealized flow lines
- Average slope of the water table dh/dl determined from measurements in the observation wells: 1 m/2,000 m

Using Eq. 4-18

$$T = \frac{Q}{W} \times \frac{dl}{dh} = \frac{5,616 \text{ m}^3}{5,000 \text{ m}} \times \frac{2,000 \text{ m}}{1 \text{ m}} = 2,246 \text{ m}^2/\text{d} \quad (\text{Eq. 4-20})$$

The hydraulic conductivity is determined from Eq. 4-12 as follows:

$$K = \frac{T}{b} = \frac{2,246 \text{ m}^2}{50 \text{ m}} = 45 \text{ m/d} \quad (\text{Eq. 4-21})$$

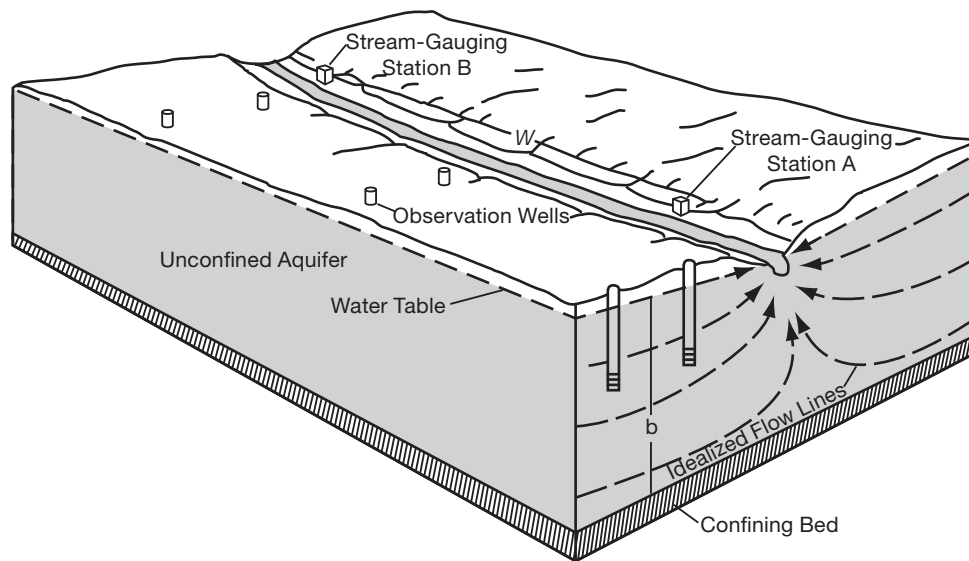

Figure 4-13 Calculation of transmissivity using stream discharge

Because transmissivity depends on both K and b , its value differs between aquifers and from place to place in the same aquifer. Estimated values of transmissivity for the principal aquifers the United States range from less than $1 \text{ m}^2/\text{d}$ for some fractured sedimentary and igneous rocks to more than $1,000,000 \text{ m}^2/\text{d}$ for cavernous limestones and lava flows.

Finally, transmissivity replaces the term *coefficient of transmissibility* because, by convention, an aquifer is transmissive and the water in it is transmissible.

STORAGE COEFFICIENT

The abilities of water-bearing materials to store and transmit water are their most important hydraulic properties. These properties are given either in terms of a unit cube of the material or in terms of a unit prism of an aquifer, depending on the intended use. These abilities, as they relate to the two units of measurement, are

Property	Unit Cube of Material	Unit Prism of Aquifer
Transmissive capacity	Hydraulic conductivity K	Transmissivity T
Available storage	Specific yield S_y	Storage coefficient S

The storage coefficient S is defined as the volume of water an aquifer releases from or stores per unit surface area of the aquifer per unit change in head. The storage coefficient is a dimensionless unit, as the following equation shows, in which the units in the numerator and the denominator cancel.

$$S = \frac{\text{volume of water}}{(\text{unit area})(\text{unit head change})} = \frac{\text{m}^3}{(\text{m}^2)(\text{m})} = \frac{\text{m}^3}{\text{m}^3} \quad (\text{Eq. 4-22})$$

The size of the storage coefficient depends on whether the aquifer is confined or unconfined (Figure 4-14), and also formation properties. If the aquifer is confined, the water released from storage when the head declines comes from expansion of the water and from compression of the aquifer. Relative to a confined aquifer, the expansion of a

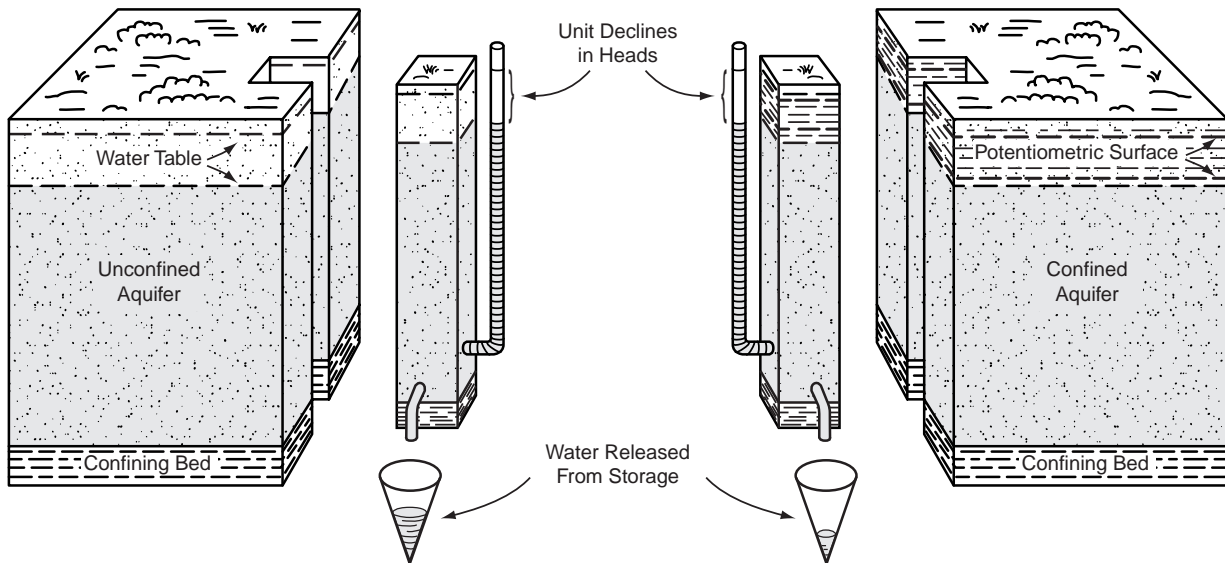

Figure 4-14 Definition of storage coefficient

given volume of water in response to a decline in pressure is very small. In a confined aquifer having a porosity of 0.2 and containing water at a temperature of about 59°F (15°C), expansion of the water releases about 3×10^{-7} m³ of water per cubic meter of aquifer per meter of decline in head.

To determine the storage coefficient of an aquifer as a result of expansion of the water, the aquifer thickness must be multiplied by 3×10^{-7} . If only the expansion of water is considered, the storage coefficient of an aquifer 33-ft (100-m) thick would be 3×10^{-5} . The storage coefficient of most confined aquifers ranges from about 10^{-3} to 10^{-5} . The difference between these values and the value as a result of expansion of the water is attributed to compression of the aquifer.

Field Testing

Field-testing methods for determining transmissivity or the storage coefficient have been developed and are thoroughly documented. These methods apply a regulated stress (pumping) to the formation and measure the effects (changes in water level) produced. The data are then analyzed and the transmissivity and storage coefficient are calculated. Determining transmissivity or the storage coefficient by any means other than actual performance tests in the field is expensive, time consuming, and of questionable accuracy.

To obtain the required data, one or more nearby wells tapping the aquifer serve as observation points, or a number of small-diameter test wells are installed in the area of investigation. The location of all wells must be accurately plotted on the area map so that the lateral distance and direction from the pumping well and the relative position with respect to other wells can be included in the analysis. No set number of wells is required, but having more wells reduces the likelihood of making an error. For best results, the outlying wells from the test well should be fully penetrating the source aquifer thickness being tested.

Water-Level Measurements

A benchmark should be used to survey the elevations of the wells. By accurately measuring water levels with respect to surface elevations, groundwater gradients can be determined. For this purpose and for the collection of water-level data during an aquifer performance test, a reference point on the casing should be established. All measurements to water levels are made from that point. Data sheets should be used that adequately identify each well by number or other description. When a water-level measurement is made, the date, time, and distance to water should be accurately recorded.

Tape method. Although seldom used in practice, especially for well testing, water levels can be measured using a hand-held tape with a weight attached to the end to hold it straight and taut. The tape should be metal, and graduated in feet and in tenths and hundredths of a foot, or in metric units. Such graduations facilitate calculations by eliminating conversion of fractions to decimal equivalents. By chalking the lower portion of the tape and lowering it into the water until an even foot graduation coincides exactly with the reference point, the precise distance to water from the reference can be made by subtraction. The wetted chalk is easily identified, and direct readings to one hundredth of a foot can be made. This only works in relatively static conditions and is no longer standard practice in well testing.

Electric water-level sounders. A long-available and commonly used water-level measurement method is the electric water-level sounder or probe. This is usually an electric tape that has an insulated wire with open-end weighted electrodes on the end. When the electrode enters the water, it completes a circuit that actuates a light, buzzer, meter, or other signal device. The distance to water is then read directly from graduations on the wire line. Both flat engineering-tape and etched-cable types are available that permit reading water level accuracy reliably to 1/100th of an inch or to 1 mm. Sounder electrodes must be kept clean of deposits, especially those that can accumulate during long pumping tests in aggressive water and cause damage to the probe.

Sonic water-level sounders. Sonic meters offer a wireless option for water-level measurements. Historically not considered accurate, some claim accuracy of 0.1 ft (30 mm), which can be sufficient for many monitoring purposes. Some models can be equipped to record data.

Transducer-based water-level measurement. Pressure transducers (with calibration for atmospheric pressure) can be used for highly accurate water level measurement throughout testing intervals. Accuracy is comparable to the 0.01-ft (> 3-mm) accuracy standard of electric water-level sounders, though at higher cost than for sonic sounders. Transducers can take measurements at short intervals (seconds), and can provide an electronic record of the test that can be exported for analysis. The data collection interval is set for project need. While transducer recorders can offer a “set-and-forget” option for data collectors, their records should be supplemented by manual water-level measurements. Lightning strikes and other electromagnetic pulses can disable transducers. In aquifer tests, a transducer is installed in each pumping and observation well. Transducers are also used for long-term permanent water-level monitoring, and permit data transmission to remote locations and monitoring wells situated where human access is difficult or hazardous.

Float-actuated recording devices also provide a means of collecting data continuously, but the response time drive is not fast enough for the early periods of a test program. These methods, common into the 1980s, are largely replaced by transducer recorders for both well tests and long-term monitoring, due to their greater reliability, simplicity, and smaller size.

Air-line devices have little value for controlled tests, except where water-level fluctuations are very large. They also clog and become unreliable for routine water level monitoring.

COLLECTION OF TEST DATA

Test data must be collected and recorded carefully. Because water-level data are commonly plotted manually on a logarithmic time scale, the measurement increments should coincide with the plotting technique.

Collection Schedule

A manual data collection schedule in minutes (min) that can be easily followed and provides adequate data is shown below (some jurisdictions specify the intervals, so check for such requirements):

1 reading at zero time	total elapsed time	=	0 min
1 reading each 1 min for 10 min	total elapsed time	=	10 min
1 reading each 2 min for 10 min	total elapsed time	=	20 min
1 reading each 5 min for 20 min	total elapsed time	=	40 min
1 reading each 10 min for 60 min	total elapsed time	=	100 min
1 reading each 20 min for 80 min	total elapsed time	=	180 min

After 180 minutes, the readings should be recorded at one hour intervals, or longer if change is slow. All times are calculated from the precise instant that the pump is turned on or off, which is designated as zero. If the test extends beyond 24 hr, subsequent measurements can be made at about 4-hr intervals. The timing of measurements at the onset of the test is critical. If entirely relying on manual measurements, at least one observer equipped with measuring devices and a synchronized stopwatch should be recording at each well. After 180 min, measurements do not have to be made at a designated instant, but an accurate record for the exact time of each measurement should be maintained. Transducer recorders permit such multiple-well tests to be conducted by one hydrogeologist and an assistant monitoring flow rates.

Note that maintaining flow rate is critically important. In a constant-rate aquifer test, the flow rate must, of course, be maintained constant throughout the test. As the output flow rate of centrifugal pumps tend to drop with increased drawdown (increased pumping head), the flow must be monitored and adjusted as necessary. In step-drawdown tests, the flow rate must be maintained steady through the step, then adjusted to the next step. At times, pump flow rate may not be kept steady. If this is the case, knowing the flow rate permits useful analysis.

ANALYSIS

The following discussion of common procedures for analyzing aquifer test data is adapted from Brown (1953), from early in the development of aquifer testing. Other more recent references are also available (see the references at the end of this chapter).

All procedures discussed are designed to yield information on aquifer performance, not well performance. Hydrogeologists should perform these analyses. Each method will involve turning a pumped well on or off and observing what happens to the water level in nearby observation wells. All methods use the Theis nonequilibrium formula or modifications of the formula. The formula, developed by C.V. Theis, takes into account the time that has elapsed since pumping began or ceased. Note that such analysis is most

typically conducted by credentialed hydrogeologists and using type-curve matching or other analytical software, such as AQTESOLV. However, manual type-curve matching is entirely appropriate in qualified hands.

Ideally, all wells used in the analysis should fully penetrate the aquifer. Some departures from this requirement can be tolerated, but the construction details of the wells are required. Any pumps in the area that are not involved in the test should be stabilized before an aquifer test and maintained for the duration of the test. During the test, well pumping should be at a steady unvarying rate, and carefully measured. The pumping rate and water-level data should be carefully computed and plotted. Each method uses the Theis formula to analyze variations in drawdown with time, or variations in drawdown with distance from the pumped well.

Hypothetical Test Setup

A hypothetical test setup is shown in Figure 4-15. This illustration depicts a sand aquifer that is confined above and below by relatively impermeable clay. One well will be pumped at 500 gpm, and water-level changes in wells 1 and 2 will be measured. The wells fully penetrate the aquifer and, as best can be determined from the sectional view, the aquifer extends laterally to infinity, relative to the effects of pumping. No nearby wells are pumping that might affect the test. The observation wells could have been located anywhere in the general vicinity of the pumped well, but, for convenience, they were placed in a straight line.

A family of type curves has been developed to facilitate aquifer evaluation under a variety of conditions. The basic formulas are

$$T = 114.6 QW(u)/s \quad (\text{Eq. 4-23})$$

Where:

- T = the transmissivity of the aquifer, in gallons per day per foot
- Q = the discharge rate of the well, in gallons per minute
- u = for any given formation, is proportional to the ratio of r^2/T
- r = the distance from the discharging well to the point where the drawdown is being observed, in feet
- $W(u)$ = the "well function of u " is determined from calculated tables from each value of u
- s = the drawdown at any point under study in the vicinity of the discharging well, in feet

$$u = 1.87r^2S/Tt \quad (\text{Eq. 4-24})$$

Where:

- r = the distance from the discharging well to the point where the drawdown is being observed, in feet
- S = the aquifer storage coefficient
- T = the transmissivity of the aquifer
- t = the elapsed time since discharge began, in days

Confined aquifers. A confined, or artesian aquifer is confined above and below by relatively impermeable materials. The aquifer is homogeneous and isotropic, uniform in structure, and with the same physical and hydraulic properties in all directions. In practical terms, the thickness and actual extent of the aquifer should be known to permit the best possible interpretation of the test data.

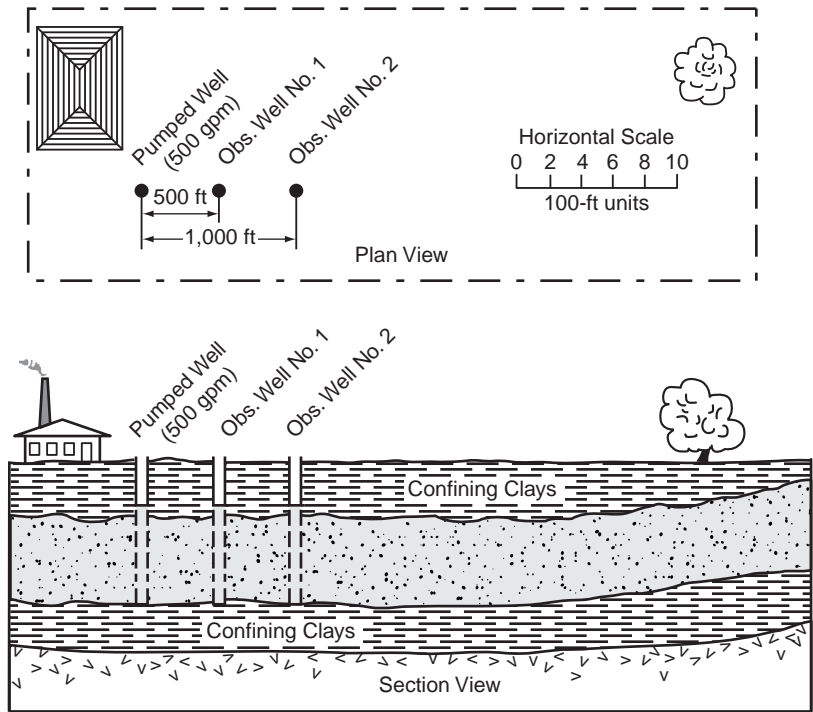

NOTE: In this hypothetical situation, one well will be pumped at the rate of 500 gpm, and water-level changes will be noted in observation wells 1 and 2.

Figure 4-15 Hypothetical test situation—infinite aquifer

Leaky aquifers. The modified nonequilibrium formula for leaky artesian conditions is based on the conditions for confined aquifers and on the following several assumptions:

- The aquifer is confined between an impermeable bed and a bed through which leakage can occur
- Leakage is vertical into the aquifer and proportional to the drawdown
- No water is stored in the confining bed
- The hydraulic head in the deposits supplying leakage remains constant

Unconfined aquifers. An unconfined, or water-table, aquifer does not have water confined under pressure beneath impermeable rocks. Water is derived from storage by gravity drainage of the interstices above the cone of depression, by compaction of the aquifer, and by expansion of water in the aquifer.

Properties of an unconfined aquifer can be determined by the Theis method under some limiting conditions. One of the basic assumptions of the Theis solution is that water is released from storage instantaneously with a decline in head. In a water-table aquifer, this is not always true, because water is derived partly from gravity drainage, and the effects of gravity drainage are not considered in the Theis formula. However, with long pumping periods, the effects of gravity drainage become negligible so that the Theis solution can be used.

Drawdown Method

In the drawdown method, one well is pumped while the water levels are observed in two or more nearby wells. Figure 4-16 is a hydrograph—a plot of water level versus time—for

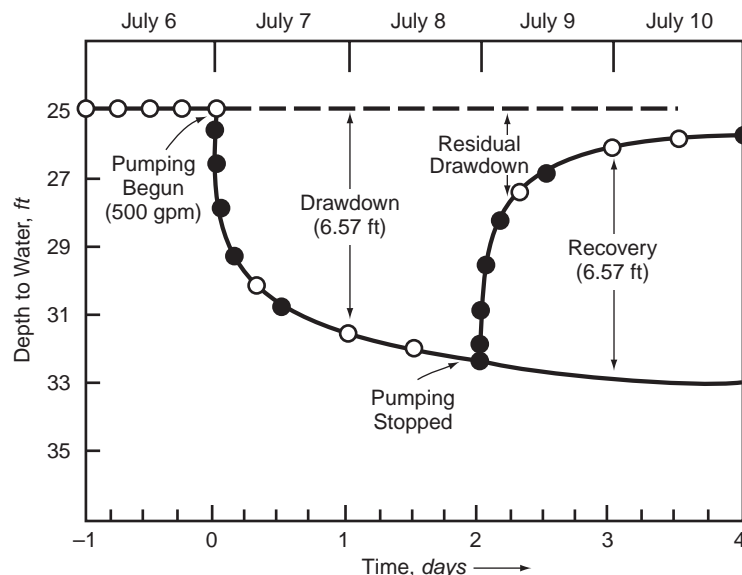

NOTE: Drawdown data are plotted on the left curve, recovery data on the right. These data are for observation well 1, located 500 ft from the pumped well. Points indicated by O are used in later analysis plots. Arrows indicate directions of increasing scale values.

Figure 4-16 Hydrograph for observation well No. 1

observation well No. 1 (Table 4-3). Only the left half of Figure 4-16 should be considered at this point. Water-level measurements were taken for a day before the start of the test to determine whether any preexisting upward or downward trend would have to be considered during the test. No upward or downward trend of water levels is assumed in the area, and the measurements are plotted on a horizontal line. Referring to the portion of the hydrograph after pumping starts, the drawdown represents the difference between the water level observed in the well and the level at which the water would have stood had no pumping occurred. In the drawdown method, similar data will be collected for the observation wells and analyzed during the test. In the analysis, either the type-curve or straight-line solutions can be used. Note this method works best in water-table aquifers. The testing time should be extended because historically confined aquifers tend to decline with time.

Type-curve solution. In manual analysis, aquifer transmissivity and storage coefficients can be determined by comparing a logarithmic curve of time versus drawdown against one of a series of type curves developed from the Theis formula. The type curve is superimposed over the field-data plot, keeping the respective graphical axes parallel. In curve-matching software, data in spreadsheet form are imported and the software “draws” and compares the curves for analysis.

The curves are adjusted horizontally and vertically to obtain the best match of the two curves. An arbitrary match point is selected on the two graphs, and the field-curve and type-curve coordinates for substitution in the appropriate equation (Figure 4-17) are selected.

A different form of the type-curve solution is the distance-drawdown method. In this analysis, drawdown in three or more observation wells at different distances from the pumped well is compared with another interpretation of the type curve.

Detailed examples of analysis and variations of the type-curve form of solution are not given here; references are cited for additional details in the reference section at the end of this chapter. Scientists in the field of groundwater hydrology may develop individual

preferences for specific analytical methods, but the fundamental principles and theory are common to all. The particular method favored will often be governed largely by the physical setup for collecting data. Development of computer programs has provided rapid advances to assist in the analysis of well-test data.

Straight-line (Jacob) solution. A second form of solution available for analyzing aquifer test data is an approximate version of the type-curve solution. Well-test data are plotted on semi-logarithmic paper and variations of the basic formula are used to compute the aquifer transmissivity and storage coefficient. If test conditions meet the criteria, the drawdown data tend to follow a straight line when plotted on semi-log paper (Figure 4-18).

While simpler for manual analysis and suitable for preliminary purposes, especially for confined aquifers, a straight-line analysis, depending on the curve slope, can over- or underestimate parameters.

Table 4-3 Drawdown test data for observation wells

Date (July 1989)	Hour	Elapsed Time			Drawdown* s (ft)	Depth to Water ft
		min	t (days)	t/r ²		
Well 1 (r = 500 ft)						
5	2400					25.00
6	0600					25.00
	1200					25.00
	1800					25.00
	2400 [†]	0	0	0	0	25.00
	7	0004	4	0.00278	1.1 × 10 ⁻⁸	0.44
7	0015	15	0.0104	4.2 × 10 ⁻⁸	1.50	26.50
	0055	55	0.038	1.5 × 10 ⁻⁷	2.83	27.83
	0305	185	0.13	5.2 × 10 ⁻⁷	4.22	29.22
	0600	360	0.25	1.0 × 10 ⁻⁶	4.96	29.96
	1200	720	0.50	2.0 × 10 ⁻⁶	5.75	30.75
	2400	1,440	1.0	4.0 × 10 ⁻⁶	6.57	31.57
	8	1200	2,160	1.5	6.0 × 10 ⁻⁶	7.04
8	2400	2,880	2.0	8.0 × 10 ⁻⁶	7.32	32.32
Well 2 (r = 1,000 ft)						
5	2400					25.10
6	0600					25.10
	1200					25.10
	1800					25.10
	2400 [†]	0	0	0	0	25.10
	7	0030	30	0.0208	2.1 × 10 ⁻⁸	0.89
7	0155	115	0.080	8.0 × 10 ⁻⁸	2.16	27.26
	0640	400	0.278	2.8 × 10 ⁻⁷	3.53	28.63
	2400	1,440	1.0	1.0 × 10 ⁻⁶	4.94	30.04
	8	2400	2,880	2.0	2.0 × 10 ⁻⁶	5.75

* Values in this column are derived from the depth-to-water measurements made in the observation well and given in the next column.

[†] Pumped well begins discharging at 500 gpm.

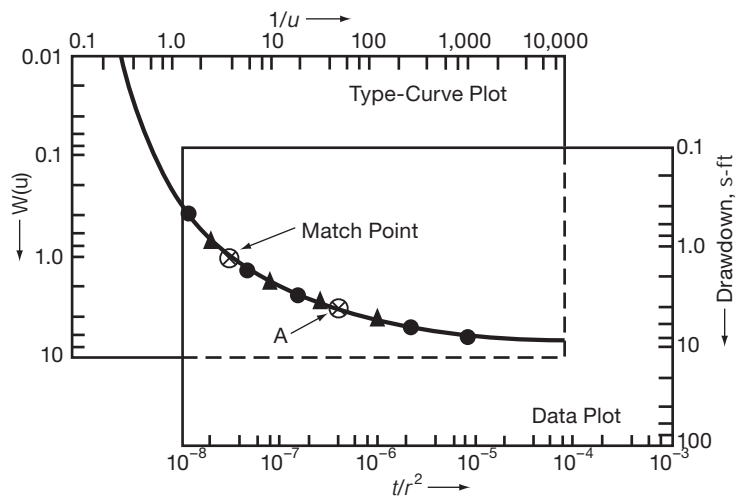

Figure 4-17 Drawdown test data superimposed on Theis-type curve

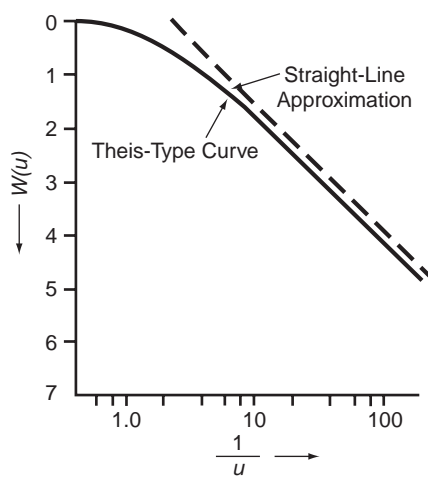
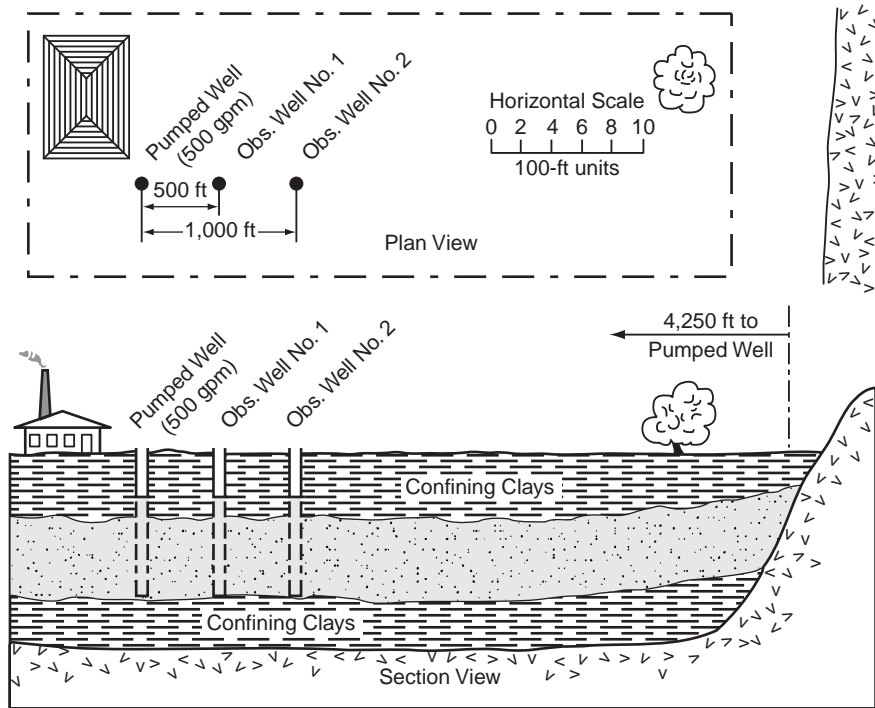

Figure 4-18 Straight-line approximation of drawdown data analysis

Identification of Aquifer Boundaries

If an aquifer is not infinite but has identifiable boundaries, the drawdown test data will be plotted differently. Two scenarios are discussed in the following sections.

Impermeable-barrier effect. The effect of an impermeable barrier around an aquifer is shown in the plan and section views of a hypothetical situation in Figure 4-19. This case is the same as illustrated in Figure 4-15, except in the right-hand direction, the aquifer is cut off by an impermeable barrier caused by the rising side of a buried valley. This situation is quite common in the northern, once-glaciated parts of the United States. Indeed, an aquifer is often cut off in two parallel directions by buried-valley walls. For the purpose of



NOTE: The situation is the same as in Figure 4-15, except that the aquifer is cut off by an impermeable barrier on the right side.

Figure 4-19 Hypothetical test situation—aquifer bounded by impermeable barrier

this discussion, the effects of a single barrier are used. For convenience, the effects will be analyzed using the straight-line solution of drawdown analysis.

The early data occur in the expected manner, with a curved portion leading into a straight line. However, instead of staying on a straight line, the plotted data now curve off and eventually define a new straight line having twice the slope of the original (Figure 4-20). In other words, drawdown in the observation wells occurs at a faster rate than if the aquifer were of infinite extent. This effect is the same as having a second well (located across the boundary at the same distance) pumping at the same rate. Two wells operating identically are called the *image well theory*.

These data will determine not only the presence and kind of aquifer boundary but an aquifer average position with respect to the pumped well. A detailed explanation of these procedures is given in numerous references some of which are found at the end of this chapter.

Recharge effect of local stream. A recharging stream is shown in Figure 4-21. The aquifer is cut off on the right side by a recharging stream—a situation that is often found in the field.

Figure 4-22 shows the recharge effect of this stream on the straight-line form of a drawdown plot. The plot begins as expected, with a curved portion leading into a straight line near point A. Instead of continuing on the straight line, as the data theoretically should for an infinite aquifer, the plotted data curve away above it and eventually defines a horizontal line. Thus, the rate of drawdown slackens, because of the water contributed to the aquifer by the stream, and gradually approaches a fixed value. This effect is the same as if a well, identical to the pumped well, was recharging the aquifer at an equal distance from and on the opposite side of the recharge boundary.

From these data, the presence and nature of the aquifer boundary can be interpreted, as well as its location with respect to the pumped well.

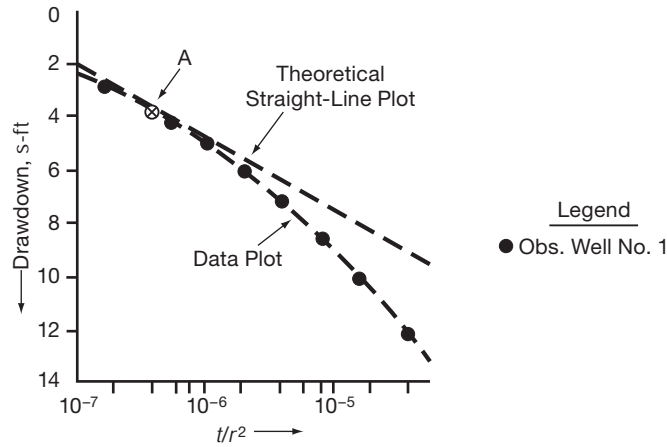

NOTE: The drawdown data depart from the theoretical straight-line plot because the impermeable barrier limits the extent of the aquifer and increases the drawdown rate.

Figure 4-20 Effect of impermeable barrier shown on straight-line drawdown plot

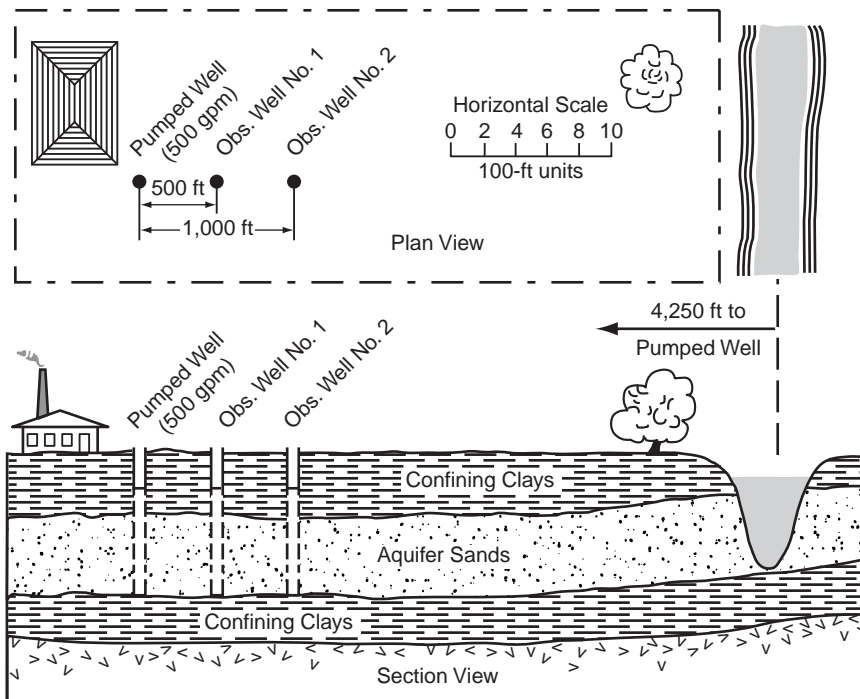

NOTE: The situation is again the same as in Figure 4-15, except that the aquifer is bounded on the right by a recharging stream.

Figure 4-21 Hypothetical test situation—aquifer bounded by recharging stream

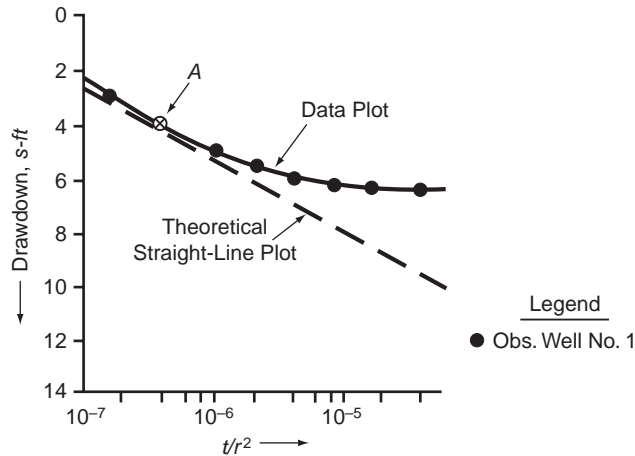

NOTE: Instead of following the theoretical straight-line plot, the drawdown data curve shows an upward trend because the recharging stream replenishes the aquifer, reducing the drawdown rate.

Figure 4-22 Effect of recharging stream shown on straight-line drawdown plot

Recovery Method

The recovery method of analyzing aquifer test data involves shutting off a pumped well and observing the recovery of water levels in nearby observation wells. In considering the types of solutions available, Figure 4-16 should be reviewed to see how recovery is measured. Recovery is the difference between the observed water level in the well at some time after pumping has stopped and the level at which the water would have been, had pumping continued. The hydrograph in Figure 4-16 shows that one day after pumping stopped, a recovery of 6.57 ft occurred, which equaled the drawdown observed one day after pumping began.

Type-curve solution. The same type curve as in the drawdown method is used, except that it has been inverted. The inverted curve indicates the rising levels in the observation wells. A plot of recovery measurements for the observation wells is an upside-down version of the drawdown plot. The recovery curve is compared with the inverted type curve to determine the transmissivity and storage coefficient. The values should be similar to those obtained using the drawdown method of analysis.

Straight-line solution. As in the drawdown method, both the type curve and the data curve are plotted on semi-log paper. The type curve is inverted to show a rising trend in the recovery period. With these modifications, the curves become straight lines. The same abbreviated equations are used to compute the transmissivity and storage coefficient.

In practice, using two kinds of type curves and two kinds of straight-line plots is not necessary. If a recovery test is essentially the reverse of a drawdown test, one type curve and one straight-line plot will serve equally well for either kind of test data. Both kinds of data can be recorded on the same plot to check their agreement.

Caution needs to be used in analyzing recovery data. Water can be extracted from the aquifer storage and very slowly recover from drainage from the unsaturated zone above. If the projected time to full recovery is significantly greater than the duration of pumping, the apparent continuous future safe yield of the aquifer is obtained by reducing the test pumping rate in proportion to the ratio of pumping time to recovery time. If a surface water source of infiltration or aquifer leakage is present, the recovery may occur more rapidly than the drawdown, in which case the reverse of the delayed recovery procedure

does not apply. Further investigation is needed to determine the appropriate maximum water yield available. The recovery measurements should always be made following test pumping for at least 8 hr and preferably a longer period.

Specific-Capacity Method

An abbreviated well-performance evaluation can be performed using a relatively short test to determine the specific capacity of the well. Specific capacity is defined as the yield of the well, usually expressed in gallons per minute per foot of drawdown (gpm/ft [m²/day]). The total drawdown in a well can be divided into two components—drawdown in the aquifer and drawdown related to well loss. Drawdown in the aquifer depends on the aquifer's ability to transmit water, and generally does not change unless the aquifer is being depleted. Drawdown because of well loss is related to the ability of the well to transmit water, and may change with time, due to turbulent flow or head loss as the water passes through the screen or well bore. Some of the factors affecting well loss include changes in chemical or bacterial quality of the water, or changes in the mechanical condition of the well itself.

Monitoring specific capacity is a valuable tool for helping detect well maintenance problems before they become critical. Tests for specific capacity should not be substituted for the more involved tests described above when a more complete well and aquifer evaluation is necessary.

REFERENCES

- Anderson, M.P. 1979. Using Models to Simulate the Movement of Contaminants Through Groundwater Flow Systems. *Critical Reviews in Environmental Control*, 9(2):97–156.
- Anderson, M.P. 1984. Movement of Contaminants in Groundwater, Groundwater Transport—Advection and Dispersion. *Groundwater Contamination*. Washington, D.C.: National Academy Press.
- Anderson, M.P. and W.W. Woessner. 1992. *Applied Groundwater Modeling Simulation of Flow and Advective Transports*. New York, N.Y.: Academic Press.
- Anderson, T.W. 1972. Electrical-Analog Analysis of the Hydrologic System, Tucson Basin, Southeastern Arizona. Water-Supply Paper, 193–C. Denver, Colo.: US Geological Survey.
- Anonymous. 1990. *Groundwater Models Scientific and Regulatory Applications*. Washington, D.C.: National Academy Press.
- Bredehoeft, J.D. and G.F. Pinder. 1973. Mass Transport in Flowing Groundwater. *Water Resources Research*, 9:194–210.
- Brown, R.H. 1953. Selected Procedures for Analyzing Aquifer Test Data. *Jour. AWWA*. 4518–2844.
- Clarke, R.T. 1973. *Mathematical Models in Hydrology*. Rome, Italy: FAO, The United Nations, p. 281.
- Collins, M.A., L.W. Gelhar, and J.L. Wilson, III. 1972. Hele-Shaw Model of Long Island Aquifer System. *Journal of Hydraulics Division*. Proceedings of the American Society of Civil Engineers 98(9):1701–14.
- Dagan, G. 1986. Statistical Theory of Groundwater Flow and Transport: Pore to Laboratory, Laboratory to Formation, and Formation to Regional Scale. *Water Resources Research* 22 (9) (Supplement): 120S–34S.
- Driscoll F.G. 1986. *Groundwater and Wells*. St. Paul, Minn.: Johnson Division.
- Durbin, T.J. 1978. Calibration of a Mathematical Model of the Antelope Valley Groundwater Basin, California. US Geological Survey Water Supply Paper 2046: p. 51.
- Faust, C.R. and J.W. Mercer. 1980a. Groundwater Modeling: Numerical Models. *Groundwater*, 18(4):395–409.
- Faust, C.R. and J.W. Mercer. 1980b. Groundwater Modeling: Recent Developments. *Groundwater*, 18(6):569–577.
- Fetter, C.W. 1996. *Applied Hydrogeology*. New York, N.Y.: MacMillan College Publishing Company, p. 691.
- Gelhar, L.W. 1986. Stochastic Subsurface Hydrology from Theory to Applications. *Water Resources Research*, 22 (9) (Supplement): 135S.
- James, R.V. and J. Rubin. 1972. Accounting for Apparatus-Induced Dispersion in Analysis of Miscible Displacement Experiments. *Water Resources Research*, 8:717–721.

- Kimbler, O.K. 1970. Fluid Model Studies of the Storage of Freshwater in Saline Aquifers. *Water Resources Research*, 6:1622–1627.
- Krusemann, G.P. and N.A. de Ridder, 1994. *Analysis and Evaluation of Pumping Test Data*, ILRI Publication 47, International Institute for Land Reclamation and Improvement, Wageningen, The Netherlands.
- Mercer, J.W. and C.R. Faust. 1980. Groundwater Modeling: Mathematical Models. *Groundwater*, 18(3):212–227.
- Mercer, J.W. and C.R. Faust. 1981. *Groundwater Modeling*. Dublin, Ohio: National Water Well Association.
- Peter, Y. 1970. Model Tests for a Horizontal Well. *Groundwater*, 8(5):30–34.
- Peterson, F.L., J.A. Williams, and S.W. Wheatcraft. 1978. Waste Injection into a Two-Phase Flow Field. Sand box and Hele-Shaw Model Study. *Groundwater*, 16:410–416.
- Pinder, G.F. and W.G. Gray. 1977. *Finite Element Simulation in Surface and Subsurface Hydrology*. New York, N.Y.: Academic Press.
- Prickett, T.A., 1975. Modeling Techniques for Groundwater Evaluation. *Advances in Hydroscience*, Vol. 10 ed. V.T. Chow: 1–143. New York, N.Y.: Academic Press.
- Prickett, T.A. and C.G. Lonquist. 1971. Selected Digital Computer Techniques for Groundwater Resources Evaluation. Illinois State Water Survey, Bulletin 55.
- Prickett, T.A., T.G. Naymik, and C.G. Lonquist. 1981. A “Random-Walk” Solute Transport Model for Selected Groundwater Quality Evaluations. Illinois State Geological Survey, Bulletin 65.
- Rorabaugh, M.I. 1953. Graphical and Theoretical Analysis of the Step Drawdown Test of Artesian Wells. *ASCB*. No. 362, 79.
- Rubin, J. and R.V. James. 1973. Dispersion-Affected Transport of Reacting Solutes in Saturated Porous Media. Galerkin Method Applied to Equilibrium-Controlled Exchange in Unidirectional Steady Water Flow. *Water Resources Research*, 9(5):1332–1356.
- Rubin, Y. and G. Dagan. 1992. A Note on Head and Velocity Covariances in Three-Dimensional Flow through Heterogeneous Anisotropic Porous Media. *Water Resources Research*, 28(5):1463–1470.
- Schwille, F. 1988. *Dense Chlorinated Solvents in Porous and Fractured Media*. Model Experiments translated from German by J.F. Pankow. Chelsea, Mich.: Lewis Publishers.
- Spieker, A.M., 1968. Effect of Increased Pumping of Groundwater in the Fairfield–New Baltimore Area, Ohio. A Prediction by Analog Model Study. US Geological Survey Professional Paper 605–C.
- Trescott, P.C., G.F. Pinder, and S.P. Larson. 1976. Finite Difference Model for Aquifer Simulation in Two Dimensions with Results of Numerical Experiments. *Techniques of Water-Resources Investigations*, Book 7, Chapter C1. US Geological Survey.
- Van Der Heijde, P., Y. Bachmat, J. Bedeohoft, B. Andrews, D. Holtz, and S. Scott. 1985. Groundwater Management. The Use of Numerical Models, 2nd ed. *American Geophysical Union*, Water Resources Monograph 5.
- Walton, W.C. 1984. *Practical Aspects of Groundwater Modeling*. Westerville, Ohio: National Water Well Association.
- Wang, H.F. and M.P. Anderson. 1982. *Introduction to Groundwater Modeling—Finite Difference and Finite Element Methods*. San Francisco, Calif.: W.H. Freeman.
- Welty, Claire and L.W. Gelhar. 1992. Simulation of Large-Scale Transport of Variable Density and Viscosity Fluids Using a Stochastic Mean Model. *Water Resources Research*, 28(2):815–828.
- Williams, D.E. 1985. Modern Techniques in Well Design. *Jour. AWWA*. 77(9).

This page intentionally blank.

Wells—Types, Construction, Design, and Use

Many methods of well construction have been developed, and several construction types are used in most areas. This chapter provides an overview of various types of construction and some of the limitations that control selection of a particular type of well. Proper well construction should be based on a thorough engineering study and design to best accommodate existing conditions or requirements.

TYPES OF WELLS AND THEIR CONSTRUCTION

Wells have been a source of water since prerecorded history, and methods of constructing wells are as varied as the people and tools available throughout history. A well can be as simple as a hand-dug hole lined with brick tapping a shallow aquifer, or as complex as a machine-drilled well tapping layered aquifers hundreds of feet underground. The selection of a particular type of well is usually guided by characteristics of the aquifer being tapped and the drilling equipment and engineering expertise in the particular area.

A well is generally described by the method of construction used to complete the well: dug, bored, driven, or drilled. A fifth type of well is the radial (or horizontal) collector well, which is named for its configuration rather than its method of construction. An emerging concept is the use of directionally drilled wells that can be set at any configuration or angle. Each type of well has advantages, such as ease of construction and maintenance, storage, capacity, ability to penetrate various formations, and ease of safeguarding against contamination. In most applications, however, the vertical well remains the most common type of well construction.

Dug Well

This type of well technology is currently rarely used in the United States and Canada. It may be appropriate for developing countries.

A dug well can furnish relatively large supplies of water from shallow sources. The yield from a dug well increases with diameter, but the increased yield is not proportional to the increased size. A dug well is of large diameter, usually 8 ft to 30 ft (2 m to 9 m), when installed for municipal purposes, with a depth varying from 20 ft to 40 ft (6 m to 12 m). Because of the large opening, dug wells are easily polluted by surface water, airborne material, and objects falling into or finding entrance into the well.

Construction. Generally, a dug well is circular, because this shape adds strength and is usually easier to dig. Material is frequently excavated using a pick and shovel, or a hoist with a bucket. Clamshell buckets with power hoists can be used when no large boulders or thick layers of clay or hardpan are encountered.

If the formation in which the well is being dug will stand without support, lining the excavation may not be necessary until the water table is reached. Below the water table, sheet piling temporarily braces the sides of the excavation. After the lining or casing (usually called the *curb*) is placed, the piling is removed. Some older wells are brick-lined.

To minimize water pollution, monolithic concrete curbs are used. The curbs are precast in rings 3 ft to 4 ft (1 m to 1.2 m) high with a beveled bottom edge and smooth surfaces that will sink easily (see Figure 5-1). Earth is dug out from under the beveled edge and subsequently the curb will sink. As the well is dug deeper, additional curbs are stacked on top of the original curb to give it more weight and allow it to sink. The rings are reinforced with vertical rebar. The portion of a curb that lies in the water below the limit of drawdown should be perforated with short pieces of pipe, several in each square foot (0.09 m²). Graded gravel should be placed around the outside of the curb to keep sand from coming through the perforations. Additionally, a layer of charcoal may be placed around the gravel to provide rudimentary treatment as needed. Pipe and gravel sizes depend on the natural formation grain size. Gravel should also be placed in the base of the excavated well. In some cases, precast concrete pipe sections can be used as the well casing; the sections below water must be perforated.

Once the construction of the hand-dug well is complete, a concrete apron and a head wall are constructed around the top of the well. Additionally, a cover can be installed with a door. These measures serve to mitigate unsanitary conditions at the well head and protect the water from contaminants. In developing countries, hand-dug wells can be treated on a monthly basis with doses of chlorine bleach.

Bored Well

A bored well is installed where speed and economy are important, and where water can be reached at relatively shallow depths through unconsolidated formations. An auger can be used only where formations, though relatively soft, will permit an open hole to be bored to depths ranging from 25 ft to 100 ft (8 m to 30 m) without caving. The most suitable formations for bored wells are glacial outwash till and alluvial or glacio-fluvial valley deposits. Bored wells are limited to about 36 in. (1 m) internal diameter. Large bucket augers can be used to construct large-diameter bored wells for high-capacity municipal water supply. This kind of construction is common in Midwestern glacial-fluvial aquifer settings and yields 3,000 gpm to 4,000 gpm.

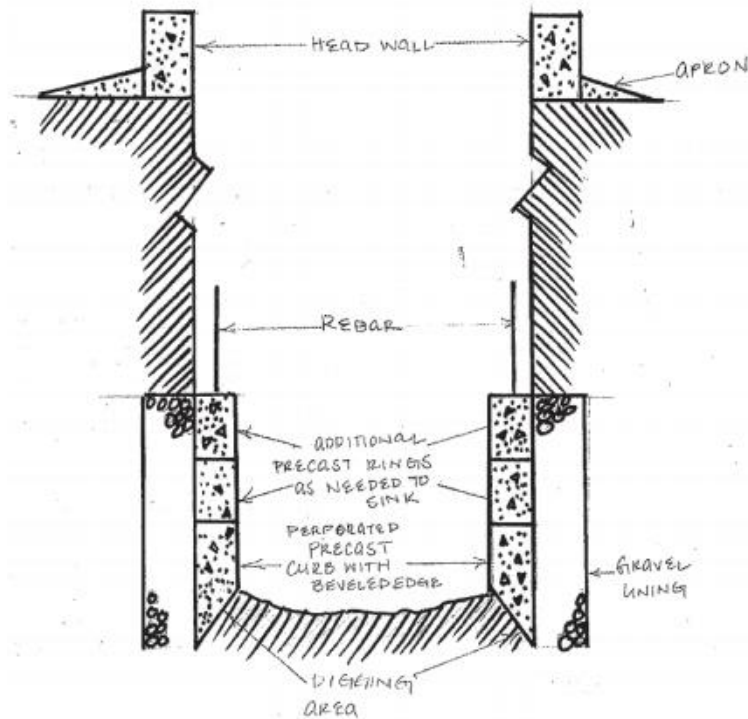

Figure 5-1 Dug well

Construction. Small bored wells such as those for expedient water supplies may be constructed using either hand or power augers. The same type of hand auger used for digging shallow holes can be used for well construction. However, extensions are needed for the auger to handle the greater depths encountered in well construction. Power-driven augers are half-cylinder, open-blade, or cylindrical-bucket-types with cutting blades at the bottom. The material cut by the blade is collected in buckets lowered into the hole and then removed. Bucket-type augers can be used to construct wells up to 36 in. in diameter and can be used where large boulders are present. This method of drilling is commonly used for short-term wells, such as for construction dewatering, or for recovery wells for cleaning up groundwater contamination; however, bored wells are also used for municipal water supply, especially in glacio-fluvial deposits, where large boulders are encountered that cause excessive deviation in rotary drilling. It can also be used to identify whether boulders are present in an aquifer to an extent that would limit the feasibility of some construction techniques.

As sand and gravel are encountered below the water table, the well casing is lowered to the bottom of the hole. Boring continues by forcing the casing down as the material is removed from the hole. After the well is completed, the annular space between the borehole and outside of the casing should be filled with cement grout to prevent the supply from becoming contaminated. The driven casing may be preperforated, or may need to be perforated during construction.

Driven Wells

Driven wells are simple to install and economical, but practical only where the water table is shallow. A driven well consists of a pointed screen, called a *drive point* or *well point*, and lengths of pipe attached to the top of the drive point. The drive point is a perforated pipe

covered with woven wire mesh, a tubular brass jacket, and is similar to screens for drilled wells and is adaptable to driving. A pointed steel tip at the base of the drive point breaks through pebbles and thin layers of hard material and opens a passageway for the point. A driven well varies from 1¼ in. to 4 in. (32 mm to 100 mm) in diameter and from a maximum of about 30 ft to 40 ft (9 m to 12 m) deep.

For municipal water supplies, the driven well is used where thin deposits of sand and gravel are found at shallow depths. The production rate of these formations is limited, and a single well does not produce sufficient water. A battery of well points, however, with the wells located a reasonable distance apart and connected by a common header to the pump, could develop sufficient water to supply a small community. In this case, a suction pump raises water in the wells to a point where it can be pumped into the distribution system. This configuration is typically limited to areas where the water table is within about 15 ft (70 m) of the surface. Driven wells are also used as observation wells during aquifer tests.

Construction. Driven wells are like well points. When constructing a driven well, an outer casing is first installed and the material in the inside removed. The inner casing then is installed inside the outer casing. The outer casing protects the inner casing to which the pump is attached. A partial vacuum occurs in the inner casing that can draw contamination at leaking joints. The outer casing is usually 2 in. (50 mm) larger in diameter than the well casing. It should extend a minimum distance of 10 ft (3 m) below the ground surface.

In sand and gravel, the outer casing should extend to just above the drive point. The outer casing can be driven with a sledgehammer. A tripod and pulley can be used, which raises and lowers a heavy block onto a drive cap placed on top of the casing. Extra heavy pipe should be used to withstand the load. The sand and gravel in the outside casing are removed by an auger during driving. If the ground is clay, the outside casing should be set in a hole prepared with an auger. Under such conditions, a 50-ft (16-m) depth usually affords sufficient protection. After the casing is set, the annular space between the borehole and the outside of the casing should be sealed with cement grout.

The next step is to lower the drive point, attached to the bottom of a string of inner casing, into the hole. The drive point is driven below the bottom of the outside casing to the water-bearing formation. This depth may be tested periodically by pouring water down the well casing and observing how quickly the water moves down the well. This can be accomplished by attaching a pump, or by jetting water down inside the casing to wash out the screen. When the final depth has been reached, raising or lowering the pipe 1 ft (0.3 m) or so frequently brings a greater portion of the screen into contact with the water-bearing formation, resulting in increased production.

Drilled Wells

A drilled well is commonly used for municipal supply and can develop water from both shallow and deep sources in unconsolidated sands and gravels or rock. Pipe diameters range from 2 in. to 48 in. (50 mm to 1,210 mm) and greater for drilled gravel-wall wells. High-capacity wells can be developed that can produce up to thousands of gallons per minute, provided that the aquifer can support these production rates.

Construction. Well drilling is a complex and specialized construction task and is only summarized here. The reader is referred to Bloetscher et al. (2007) for more information on well drilling and construction. When constructing a well, a drilling rig is used to excavate or drill a hole, and then a casing is forced or placed in the hole to prevent it from collapsing. When a water-bearing formation of sufficient capacity is reached, a screen is set in place that allows water to flow into the casing and holds back the fine material in the formation. When the drilled well passes through rock, a screen is usually not used, unless the formation is fractured.

Wells are drilled using many different types of equipment. The methods used to construct wells are classified as cable-tool, rotary, reverse-circulation rotary, California, caisson well, and jetting. Each method is briefly described in the following sections.

Drill-hole characteristics. In general (unless intended to be angled or directional), the drill hole must be straight and vertical, or plumb. Usually, in mud rotary drilling, the first indication that the hole is out of plumb is that the drilling tools begin to stick. The drilling should stop and the hole realigned when this occurs. Straight and relatively smooth holes are important to allow for sufficient annular space for cementation without channelization. A straight, vertical hole also permits the lowering of a pump to the desired depth and prevents damage to pumping equipment. Although pump manufacturers state that pumps will operate satisfactorily when slightly off vertical, a well out of alignment causes severe wear on the pump shaft, bearings, and pump column pipe. In extreme cases, lowering a pump into a well or pulling it out may become impossible.

The drilling contractor should be required to verify through testing that the completed hole is straight and plumb. In one such test, a 40-ft (12-m) length of pipe, often called a *dummy*, is lowered into the well to the depth of the lowest anticipated pump setting. The outer diameter of the test cylinder should not be more than ½ in. (13 mm) smaller than the diameter of the casing being tested. The test cylinder should move freely throughout the length of the casing. The well should not vary from the vertical by more than two-thirds the inside diameter of the well per 100 ft (30 m).

After the hole has been drilled to full depth and verified, a well screen section is lowered inside the drill casing until the screen is even with the aquifer. The drill casing is then retracted a distance almost equal with the length of the well screen to expose the formation materials to the well screen.

Formation recognition. To determine the exact kind of material being drilled, samples should be taken of the cuttings at 5-ft (1.5-m) intervals, or at each noticeable change in formation, and logged. Generally, water-bearing formations are easily detected. A sudden rise or fall of the water level in the well or increase in fluid circulation flow or increased water in air flow indicate that a permeable formation has been encountered. Often, water is added inside the drilling pipe to maintain sufficient head to prevent excess formation materials from heaving and washing inside of the casing during drilling. Sand, gravel, sandstone, and limestone formations can produce the largest quantities of water. Drill operators need to be especially watchful when drilling in these formations.

Cable-tool. The cable-tool method of drilling is used extensively for wells of smaller diameter sizes and depths (see Figure 5-2). Cable-tool methods are also called *percussion*, *spudder*, and *solid tool*. The details for constructing and operating the drilling machines vary widely, although all machines dig a hole using the percussion and cutting action of a drill bit. The bit is located at the end of a string of solid drilling tools. The drilling tools are placed at the end of a cable that is alternately raised and dropped. The drill bit, a club-like, chisel-edged tool, breaks the formation into small fragments, and the reciprocating motion of the drilling tools mixes the loosened material into a sludge or slurry.

Generally, several feet (one to two meters) of hole are drilled at each run of the drill tools. After each run, the tools are pulled from the hole and swung aside while a bailer is used to remove the slurry. The bailer consists of a 10- to 25-ft (3- to 8-m) long section of tubing with a check valve in the bottom. The bailer is smaller in diameter than the drill hole so that it can move up and down freely.

An experienced driller adjusts the length of the drill cable so that the bit will strike with the right amount of weight and stroke. The driller holds the cable and feels the jarring when the cable is dropped, which indicates how well the tools are operating. The driller adjusts the length of stroke and rapidity of blows according to the cable vibrations.

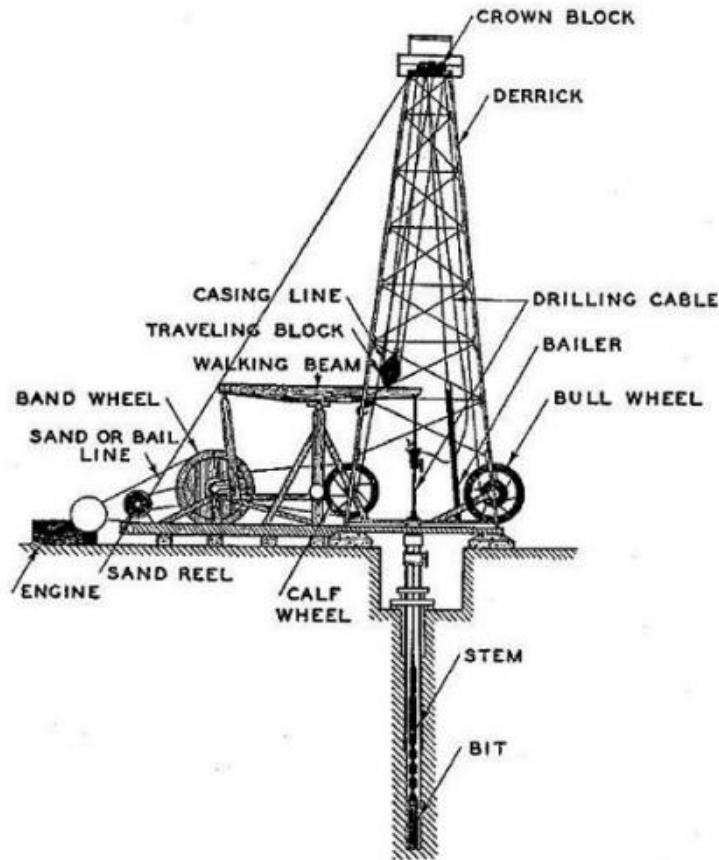

Source: California Department of Oil and Gas Summary of Operations, Vol. 42, No. 1, 1956

Figure 5-2 Typical cable-tool method of drilling to remove cuttings

Advantages of the cable-tool drilling method include: a more accurate sample of the formation is obtained compared to fluid rotary methods; the quantity and quality of each formation can be determined; and less water is necessary for drilling operations because drilling mud (see sections below) is not used during drilling, which minimizes plugging of the formation and simplifies development of the well. In most cases, a cable-tool rig is light and can traverse rough country easily, and uses far less fuel than rotary drills of similar capacity.

Rotary. In the direct “mud” rotary method of well drilling, the hole is made by rotating a drilling bit located at the end of a string of drill pipe (see Figure 5-3). This method is sometimes augmented by a percussion action, with cuttings removed by a circulating fluid. The rotation speed of the drill pipe and the bit and the type of fluid used (and its flow direction) can vary by type or form and size of bit; the characteristics of the formation to be drilled; the strength and weight of the drill pipe; and the size and depth of hole to be drilled. The bit and drilling speed should be selected so that cuttings are not produced faster than circulating fluid can carry them away. If the hole diameter becomes greatly enlarged, the up-hole velocity may be insufficient to remove the cuttings from the well.

The drill pipe is hollow, so fluid can be pumped to the bit. When drilling in unconsolidated or cemented granular formations (clay soil, sand, gravel, weak sandstone, and shale) a mud or fluid of sufficient viscosity is used to lift cuttings to the surface. The fluid must also have the necessary sealing qualities and weight, which help limit the flow of

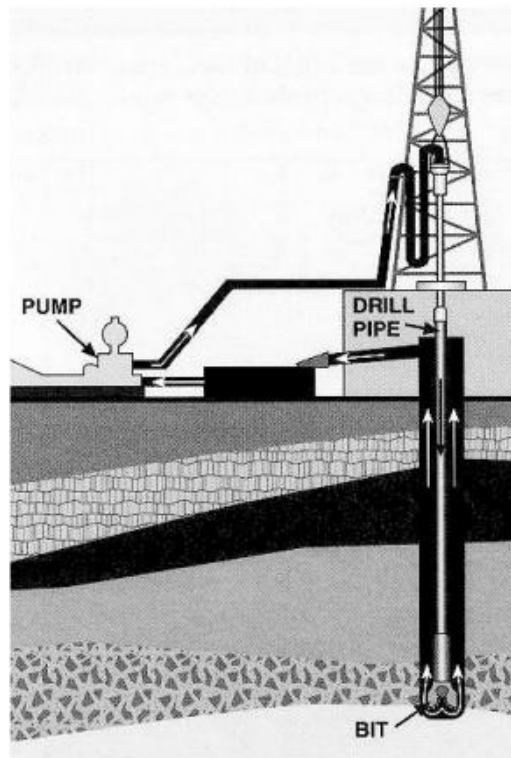

Source: www.lloydminsterheavyoil.com

Figure 5-3 Rotary method of well drilling

water into the aquifer and stabilize the well bore. The fluid may be formed by normal drilling operations, starting with clear water; however, an engineered mud fluid is preferred for the best results. The fluid is usually prepared in a large tank or pit located near the drilling rig. Clays at the site can be used, but commercial colloidal material (bentonite—sodium montmorillonite—clay base), which is purchased in powdered form and mixed with water, is preferred. Specialized polymer muds are also available for certain drilling conditions where bentonite mud is not preferred, or as a supplement.

A variation where mud is not used is air rotary drilling. Air-based fluids are also used, principally in rock drilling. The fluid may be air only, pressurized by a compressor, or air mixed with water (mist) or polymers (foam). Foam permits vastly improved cuttings clearance with any given air capacity, and is used where the fluid system (compressor and drill tools) capacity would not be able to generate enough up-hole velocity to clear cuttings. A tricone rotary bit is most often used.

Down-the-hole (down-hole hammer, hammer drilling). The down-the-hole method is a variation of air rotary drilling that employs a pneumatically operated bottom-hole drill that efficiently combines the percussion action of cable-tool drilling with the turning action of rotary drilling (ADITC 1997; NGWA 1998—see Figure 5-4). The pneumatic drill can be used on a standard rotary rig with an air compressor of sufficient capacity. It is used for fast and economical drilling of medium to extremely hard formations. Fast penetration results from the blows transmitted directly to the bit by the air piston. As in air rotary, air circulation flushes the bit and carries cuttings to the surface. Tool rotation is slow compared to air rotary drilling with a tricone bit. Air also powers the hammer. The system both hammers and rotates the tungsten-carbide bits against the borehole face to dislodge cuttings.

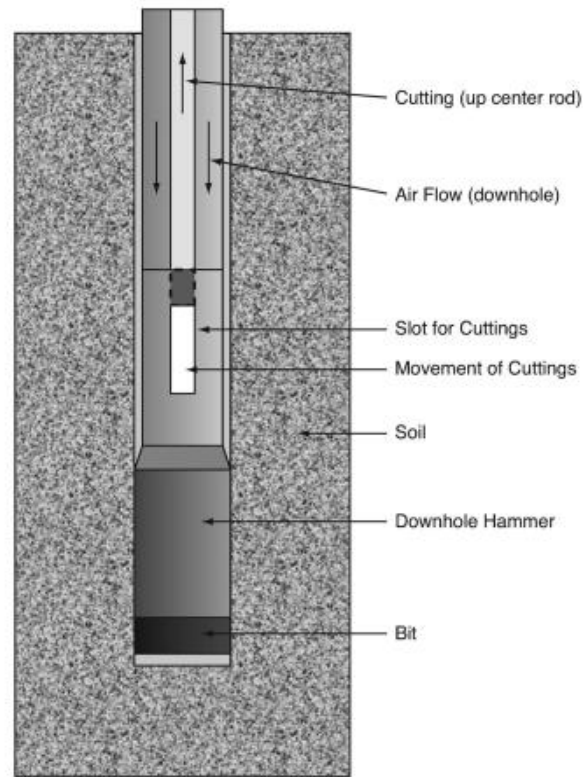

Figure 5-4 Down-hole hammer, hammer drilling

With the appropriate air capacity (volume and pressure), continuous hole cleaning exposes new formation to the bit and practically no energy is wasted in redrilling old cuttings. As the force to drill the formation is applied by the piston at the bit surface, the down-pressure necessary for air rotary hole advancement is not needed, and holes are typically straighter.

Down-the-hole drilling is generally the fastest method of penetration in hard rock, although they are slowed by high hydrostatic pressure, which can force a switch to rotary tricone. The bit is turned slowly (5 rpm to 15 rpm) by the same method by which the drill bit in the fluid or air drilling operation is rotated. Foaming additives are occasionally used to increase the up-hole carrying capacity of the return air.

The prepared fluid circulates through the drill pipe and out through holes in the bit, where it sweeps under the bit, picks up the material loosened by it, and carries it up the borehole to the surface. In mud rotary drilling, the fluid from the well flows into a settling tank or pit, where the cuttings settle out. The fluid, now free from coarse materials, flows into another pit, where it is picked up by the pump for recirculation, often after solids removal (shale shaker or desander). Formation samples are typically collected by sampling the drilling mud as it exits the borehole before it reaches the settling pit.

Reverse-circulation rotary. The reverse-circulation rotary method differs from the straight or direct rotary method in that the fluid circulates in the opposite direction (see Figure 5-5). The pit is constructed so that the drilling fluid will flow down the borehole and rise in the drill pipe, carrying the cuttings with it. A high-capacity (500 gpm [1,900 L/min] or greater) pump is attached to the drill pipe and keeps the fluid moving at high velocity. The pump may discharge to waste if a large fresh supply of water is available, or (more typically) the cuttings may settle and the fluid recirculates.

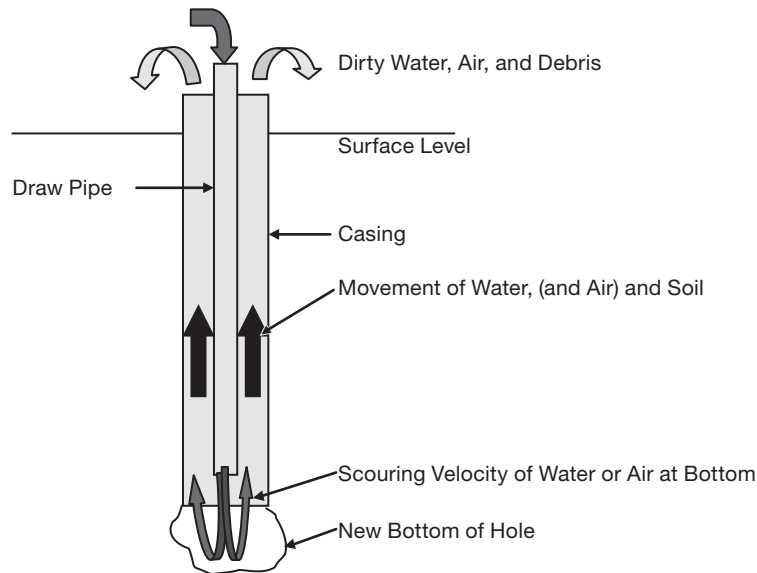

Source: Bloetscher et al. 2007

Figure 5-5 Reverse-circulation rotary method

The use of organic polymers reduces the detrimental effect of mud cake in the bore. The reverse-circulation method primarily may use clear water with no mud additives; however, bentonite-based muds may be used. Keeping the borehole open requires a large volume of water to maintain a head above the natural static water level. The head results in a flow into the formation from the bore, rather than the reverse, and prevents the wall from caving. When substantial thicknesses of materials that will not accept water are encountered, caving may result from the wash action of the fluid moving down the hole. The reverse-circulation method is particularly well suited for artificial-gravel-pack wells because less mud cake forms on the face of the bore and into the formation, reducing development time. If the formation is highly permeable and the water supply at the surface is limited, processed clays may be added (“mud the hole”), which creates a plastered hole similar to the straight rotary process. This step defeats the primary advantage of the reverse-circulation method of construction. In deeper wells being drilled with the reverse-circulation method, an air line can be added inside the drill pipe to aid in maintaining flow circulation. This also compensates for the increased viscosity of the fluid containing the formation cuttings and allows drilling to depths greater than 1,000 ft (305 m).

Typically reverse-circulation methods can drill larger holes than direct rotary methods—up to 5 ft (1.5 m) in diameter. In soft, loose, unconsolidated materials, such as dune sand and quicksand, the hole may be difficult to keep open unless the rotary method is used. It also is generally faster than cable-tool drilling for drilling wells greater than about 18 in. in diameter.

Dual-rotary. Dual-rotary drilling uses a drilling rig with two rotary drives (see Figure 5-6). One drive is typically used as a casing driver to rotate the outer drilling casing into the ground. The casing can be fitted with a hardened drive shoe or cutting shoe to help the casing penetrate rock or unconsolidated formation materials. The second drive is a standard rotary drive mounted on the drilling rig mast that uses air or fluid rotary drill pipe and bits.

The drill pipe is hollow, which allows air or water to be pumped down to the drill bit. The drill cuttings are carried up between the drill pipe and the outer driven casing to the surface. The cuttings and drill fluid are separated and samples of the formation can be

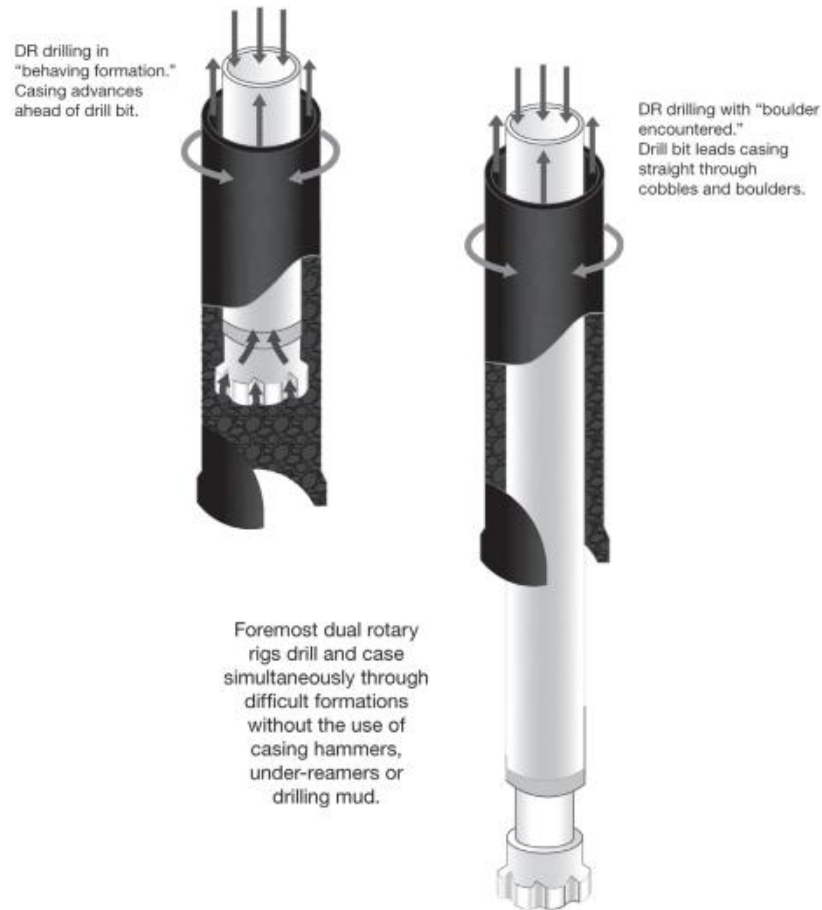

Adapted from Traut Companies

Figure 5-6 Dual rotary drilling

collected. The drilling fluid can be recirculated back to the drill bit. Drilling mud additives are typically not required, which eliminates the plugging of the formation and borehole, and simplifies well development.

Dual-rotary drilling equipment is gaining in popularity for drilling wells for both municipal water supply and in environmental applications. The main reasons are drilling mud is not needed and zones of undesirable water quality can be isolated or "cased off."

California. The California, or stovepipe, method of well construction was developed in California primarily for sinking water wells in unconsolidated alluvial materials of alternate strata of clay, sand, and gravel. Wells 16 in. to 20 in. (400 mm to 500 mm) in diameter and up to 300 ft (90 m) in depth are constructed using this method. The California drilling method uses the same general principles used in the standard cable-tool method except that a specially designed bucket is used as both bit and bailer. Short lengths of sheet metal, either riveted or welded together, are used for casing.

The mud-scow bit used in this method consists of a disk valve bailer with a sharp-edged cutting shoe on the bottom. Similar to an ordinary sand bucket, the mud-scow bit is heavier, larger in diameter, and has the cutting shoe on the bottom. Each time the bit is dropped, some part of the cuttings are trapped in the bailer. When filled, the bailer is pulled to the surface and emptied.

At the bottom end of a string of California stovepipe casing is a riveted steel starter, 10- to 25-ft (3- to 8-m) long, made of three thicknesses of sheet steel with a forged steel shoe at the lower end. This reinforcement prevents the bottom from collapsing when under pressure. Above the starter, the casing consists of two sizes of sheet steel made into riveted or welded lengths from 2 ft to 6 ft (0.6 to 2 m). The larger size casing fits snugly over the smaller size. Each outside section overlaps the inside section by half its length so that a smooth surface results both outside and inside when the casing is in place. In this way, the inner and outer joints never coincide.

The casing is forced down, length-by-length, by hydraulic jacks anchored to two timbers buried in the ground. These jacks press on a suitable head attached to the upper section of the stovepipe casing so that the end of the casing will not be telescoped. The casing may also be driven by raising and lowering the tools with a driving head.

After the casing is in place, it is perforated using a Mills knife or similar device that tears the metal. The openings must not be too large, and the pipe must not have too much area perforated.

Caisson well. This type of well is used in shallow, very loose, and permeable alluvial formations where fluid losses may exceed the capacity of the drilling water supply and where no drilling mud is to be used in the drilling process. The hole is made by bailing and sinking a very large diameter casing to about 15 ft (4.6 m). The next casing is installed in a concentric manner, one size smaller in diameter (6 in.) than the first, using the same bailing method until it is extended another 15 ft below the first casing. This process is continued until the bottom of the desired formation or the desired depth is reached. The last casing installed should be of the minimum diameter of the borehole designed or specified.

The well screen and casing are installed concentrically in the temporary inner casing, and placement of gravel in the annular space is initiated. As the gravel material is placed, the temporary inner casing is withdrawn keeping the gravel pack material about 2 m above the bottom of the casing during withdrawal. This process is continued until the gravel pack extends several feet above the well screen. A grout seal should be installed around the permanent well casing and the remaining temporary casings removed and seals installed in a similar manner. Because no fluid movement or drilling additives are used in the construction, the resulting well efficiency is high and generally little well development is needed.

Jetting. Jetting is used to drill a vertical well when water is found in sand at shallow depths. It can also be used for deep wells. Jetting equipment consists of a drill pipe or jetting pipe that is equipped with a cutting bit on the bottom end. Water is pumped into the well through the drill pipe and out of the drill bit against the bottom of the drill hole.

Casing usually is sunk as drilling proceeds. In some instances, the casing will sink a considerable distance under its own weight. Ordinarily, however, a tripod and drive weight are needed to force it into place. As a rule, one size of casing is used for the entire depth of the well. However, if a well is deep, driving a single string of casing to full depth can be difficult. Often, several strings of casing of different diameters are telescoped one inside the other to reach full depth.

After the casing is lowered to the water-bearing formation, the well screen and pipe are lowered into the casing. The outside casing provides protection to the inner casing connected to the screen. The well screen is exposed to the water-bearing formation by pulling back the outer casing a distance equal to the length of the screen (similar to the cable-tool method of drilling).

Certain conditions can make this method of well construction difficult. Rock formations and boulders are barriers that cannot be overcome. Formations of clay and hardpan are other types of materials that can present problems.

Other construction methods. Other types of construction include under-reamed and bail-down methods. The under-reamed, gravel-wall well is drilled to the top of the

water-bearing formation and the casing set. The formation is then under-reamed, and the gravel and screen section are placed. The bail-down method makes use of a cone-bottomed screen. The outer casing is sunk to the top of the water-bearing formation and the screen bailed into place while gravel is fed into the space between the inner and outer casing. In the pilot-hole method, the gravel is fed into the formation through small pilot wells evenly spaced around a central well. The fines are withdrawn through the central well.

Another type of well construction common to the mid-Atlantic and Gulf Coast states is the two-piece well construction. A large-diameter hole is drilled by the direct rotary methods to the top of the formation to be penetrated by the well screen. The outer casing is grouted to the borehole wall. The formation to be developed is drilled with an under-reamer bit to a larger diameter than the casing installed. The well screen and inner casing (or lap pipe) is installed and its gravel pack material installed by a tremie pipe. In deep wells, the inner casing must lap the outer casing with sufficient length to overcome the buoyant lift forces when the well pump is above the lap pipe. Typically this length is a minimum of 50 ft (15.2 m), with a maximum of 90 ft (27.4 m). A short section of well screen can also be installed 5 ft (1.5 m) above the regular screen to relieve the buoyant pressure in the gravel pack between the casings.

Although not commonly used for municipal water supplies in the United States, wells can be linked together through a siphon header to a common pump station. This is limited to a total lift of about 30 ft of head, and is commonly used for dewatering areas for construction. This allows a relatively large amount of water to be extracted from a shallow aquifer using a single pumping facility, and may have applications in extracting water from shallow aquifers connected to adjacent surface waters (as in riverbank filtration). This technique is used throughout Eastern Europe.

Gravel-Wall Well

Gravel-packed wells are common with drilled wells. The construction of a gravel-packed well uses larger slot sizes in the well screen section than would be possible if the area surrounding the screen were not gravel packed. The amount of open area in the screen is increased, as is the effective diameter of the well, which impacts well capacity. Also, the amount of fine sand from the water-bearing formation entering the well is reduced. Lower entrance velocities at the screen openings and increased flow per unit of head loss are also achieved.

A gravel-wall well must be carefully designed. The material used in the gravel filter must be clean, washed gravel composed of well-rounded particles. The filter size depends on the size of the natural formation and the intended slot openings of the well screen. Without proper gravel size, the fine sand will not be kept out and the yield will be adversely affected. The size of individual grains of gravel filter material should be four to six times larger than the median size of the natural material. Filter pack design as used in well construction is based on extensive experience—see Roscoe Moss (1990) or Driscoll (1986) texts listed in the reference section at the end of this chapter. The slot size for the screen should retain 90 percent of the pack material. An artificial gravel-pack filter can also be installed around the lateral well screens in a radial collector well to match finer-grained formation materials.

Construction. Selected gravel is placed between the outside of the well screen and the face of the water-bearing formation (the drilled borehole). This method is especially useful when developing water from formations composed of fine material of uniform grain size. A gravel-wall well is actually a large diameter drilled well, except that coarse material is placed around the screen instead of using the naturally occurring materials.

After the outer casing is in place, the screen is lowered to the bottom of the well and centered (see Figure 5-7). Selected gravel is added to the annular space between the

screen and the casing through a small diameter tremie pipe. The gravel is placed evenly around the screen in 2- to 4-ft (0.6- to 1.2-m) layers. As the gravel is added, the casing and tremie are slowly raised. The procedure continues until the entire screen is surrounded with gravel and the pack extends several feet ($\frac{1}{2}$ m to 1 m) above the top of the screen. The outer casing is pulled back high enough to expose the entire screen section. As a rule, the screen is attached to an inner casing, extending to the land surface, into which the pump is placed. About 25 ft (8 m) of the outer casing is typically required to provide a seal against contamination by surface water. If the entire casing is removed, the gravel treatment must not extend up to or close to the land surface. The annular space between the working casing and undisturbed earth must be sealed with cement grout or puddled clay to prevent contamination from seeping into the formation. After the gravel filter has been placed, a pipe is often installed in the finished pump base or foundation to allow additional filter materials to be added if the gravel filter settles because of normal pumping operations, well development processes, or well rehabilitation procedures.

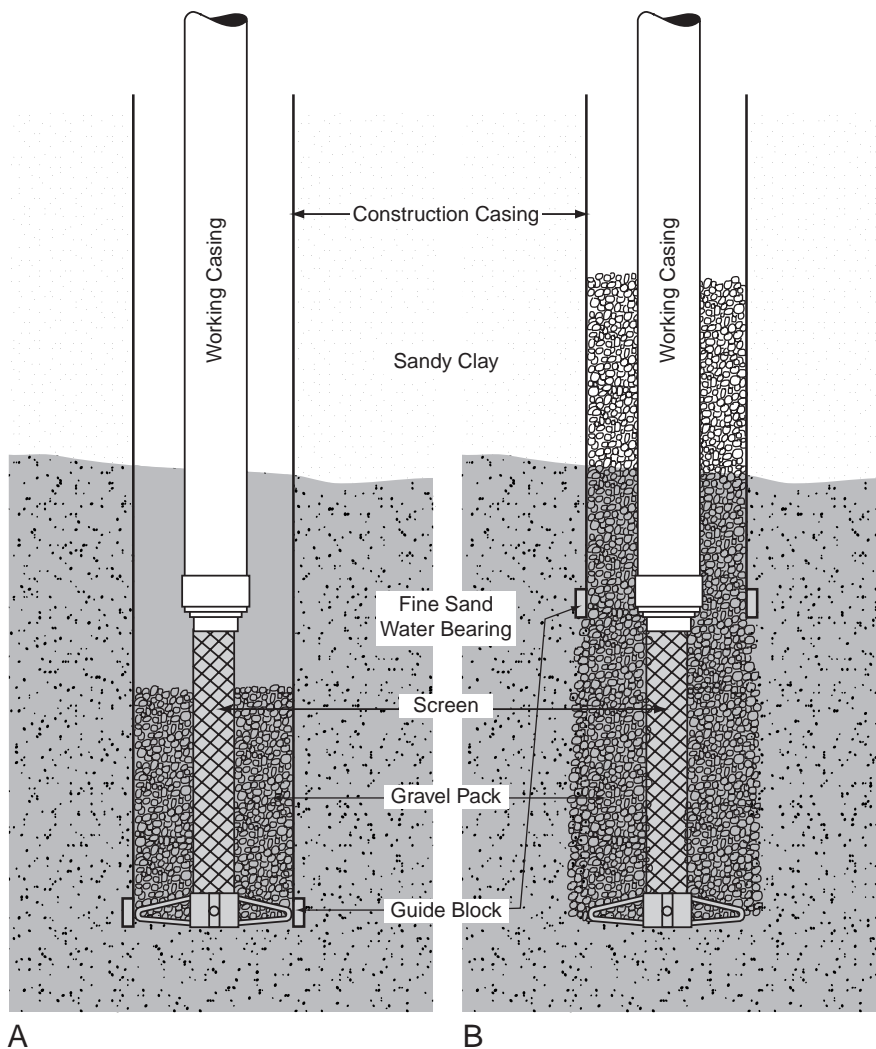

A—gravel-wall well with casing in place; B—completed gravel-wall well.

Figure 5-7 Two phases of gravel-wall well construction—gravel envelope method

Radial Well

The radial, or horizontal collector, well is widely used because it can produce very large quantities of water. In many cases, a radial well is located along the shore of a lake or river because infiltration from the water body can recharge the well.

A radial well is essentially a combination dug well and a series of horizontally driven wells projecting outward from the bottom of its vertical walls. The main well, or central caisson, serves as a collector for the water produced from the individual horizontal wells called *laterals*. The laterals are installed in coarse formations, often in more than one layer or tier. The lateral well screens can be installed and a natural gravel pack developed, or an artificial gravel-pack filter can be constructed around the well screens to accommodate finer-grained formation materials. A general schematic diagram of a radial collector well is shown in Figure 5-8.

Construction. The central caisson of a radial well is constructed of reinforced concrete. It has an outside diameter of 12 ft to more than 20 ft (4 m to 6 m) and an inside diameter ranging between 9 ft and 20 ft (3 m to 6 m). The wall is generally 12 in. to 24 in. (305 mm to 460 mm) thick and is poured in circular sections 8 ft to 12 ft (2 m to 4 m) high. The bottom of the first section, or ring, is formed with a cutting edge to facilitate the caisson's settling in the excavation and to provide a stronger bearing surface for the base of the caisson shaft. Wall ports are usually cast into the first section of the caisson, which are then used to direct the installation of the horizontal well screens.

Material is excavated from within the caisson, keeping the caisson as plumb as possible. Each section is keyed and tied to the previously poured unit for structural stability and watertightness. The final depth of the cutting edge is usually at or several feet (one meter) below the bottom of the water-bearing formation. When the caisson has been sunk to the design elevation, a concrete plug is poured in the bottom.

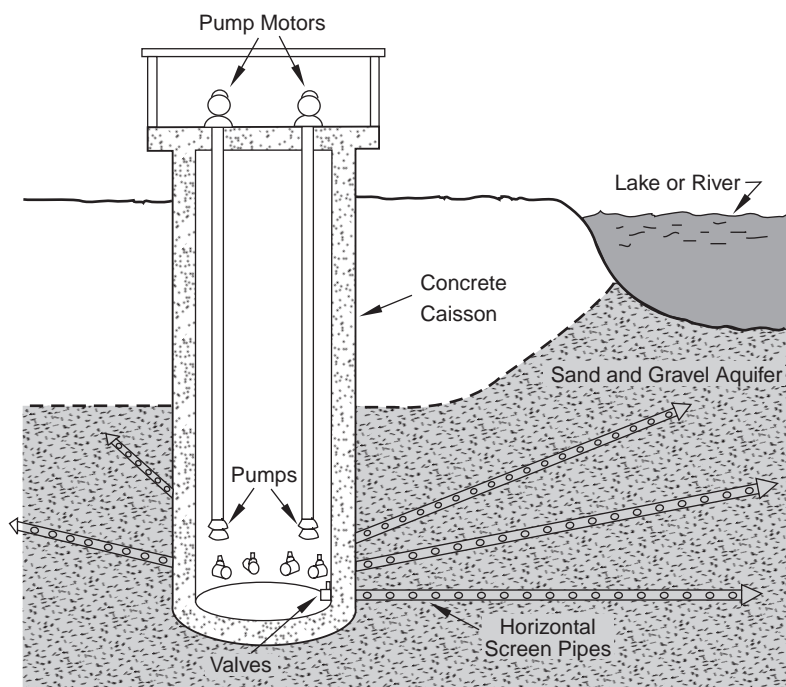

Figure 5-8 Details of a radial well

Laterals are projected horizontally through wall sleeves from the central caisson into the water-bearing formation. The laterals are constructed of slotted or perforated pipe or conventional wire-wound well screens. They are generally positioned near the bottom of the water-bearing formation. In some formations, they may be placed in a selected horizon with efficient hydraulic characteristics. The entire length of a lateral is perforated, with the exception of a 5.10 ft (1.53 m) blank section extending from the outer wall of the caisson. A gate valve is installed on each lateral inside the caisson to make it possible to cut off the flow into the caisson for dewatering. The caisson is typically extended above known or anticipated flood elevations. A superstructure is erected on top of the caisson for housing the pumps, piping, and electrical controls.

The radial well offers several advantages over conventional vertical production wells. A much greater length of well screen can be installed at a given well site because the well screen is typically placed near the base of the aquifer and is not limited to the saturated thickness of the formation. This greater length of screen results in extremely low entrance velocities through the well screen openings, reducing the rate of well screen plugging, and typically reducing well maintenance. The location of the laterals near the base of the formation also allows a greater saturated thickness of the aquifer to be used so that higher yields can be obtained at an individual well site. A higher yield allows a single radial well to replace multiple conventional vertical wells, reducing the number of pumps and well systems to be maintained.

Recently a series of radial collector wells has been interconnected through a deep-rock tunnel, allowing the collector wells to be capped at grade. This allows the pumping facility in Louisville, Ky. to be located remotely from the wells (and out of a flood plain if necessary), and thus reduces the number of pumping facilities for very large capacity systems (in this case 60 mgd). In this type of installation, the caisson is sealed against any surface water intrusion (and is not vented), requiring the caisson to be designed to withstand pressure and vacuum conditions caused by the rising and falling of groundwater and water level in the pumping station. Care must also be taken to seal the bottom of the caisson and drop-tube into the tunnel against the substantial pressure differentials between the collector caisson and the aquifer.

Horizontal Wells/Infiltration Galleries/Riverbank Filtration

Similar to radial wells is a concept called *riverbank filtration* (RBF) or *infiltration galleries*. Sometimes radial collector wells are lumped with other types of intakes under RBF. Riverbank filtration wells began in the 1870s in Germany, and have become a common water production technology in Western Europe. In the industrial regions of Europe where the existing rivers have been degraded with time, RBF provides a solution to obtain higher quality water than the river itself. As a result, it is considered as a pretreatment technology preceding more advanced treatment operations. In the United States, RBF systems have been operating for more than 70 years, and often provide the only treatment other than chlorination and fluoridation prior to consumption.

The concept of RBF is to use the natural porous sand and gravel sediments underlying water bodies to physically, chemically, and biologically remove contaminants. These contaminants include microbial constituents, metals, organics, turbidity and other pollutants from surface water by inducing water flow through the bottom and/or sides of the water body through pumping of groundwater collection devices (wells). The removal is caused by conditions of induced infiltration created by a pumping a vertical or horizontal well. Figures 5-9 and 5-10 show the basic configurations for RBF systems (Figure 5-9 uses a vertical well while Figure 5-10 shows the horizontal well configuration). More recently, in various parts of the United States, RBF has been studied as a pretreatment process prior to conventional or direct filtration and as the primary filtration process combined with

disinfection. The idea has been to use RBF as the primary filtration process in lieu of engineered conventional treatment. Due to the ability of RBF wells to filter such contaminants as turbidity and organics, RBF wells are also used in coastal aquifers to naturally filter seawater prior to reaching desalination treatment plants, possibly eliminating the need for pretreatment.

Table 5-1 summarizes the types of wells included in this chapter.

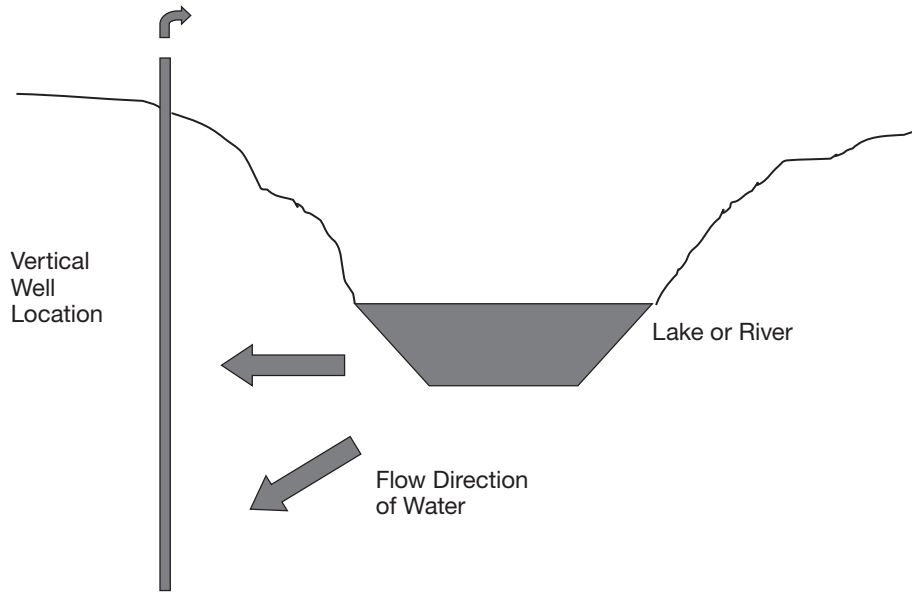

Figure 5-9 Riverbank filtration using vertical wells

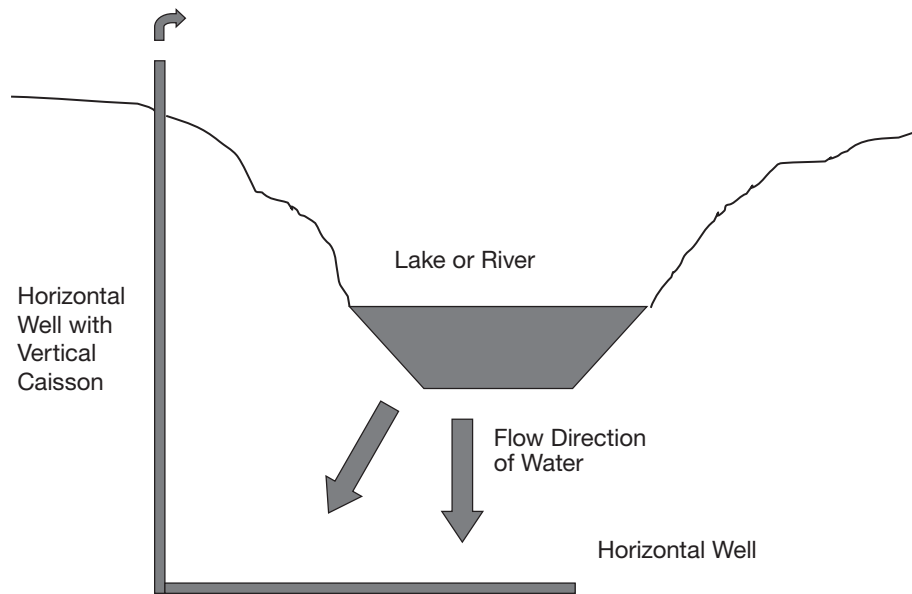

Figure 5-10 Riverbank filtration using horizontal wells

Table 5-1 Summary of well types and notes

Well Type	Diameter	Depth	Construction	Additional Notes
Dug well	8–30 ft (2–9m)	20–40 ft (6–12m)	Circular Concrete curb with beveled edge used to dig Gravel-lined wall	Commonly used in developing countries May be vulnerable to contamination
Bored well	36 in. (1 m) maximum	25–100 ft (8–30m)	Hand or powered auger Casing is driven down Annular space is filled with cement grout	Quick and economical installation Used for glacial outwash till and alluvial or glacial-fluvial valley deposits
Driven well	1.25–4 in. (32–100 mm)	30–40 ft (9–12 m)	Outer casing installed first, followed by removal of material and installation of inner casing Annular space is filled with cement grout	
Drilled wells	2–48 in. (50–1,210 mm)	Up to 2,000 ft depending on method used	Cable tool Rotary Down-the-hole Reverse-circulation rotary Dual rotary California Caisson Jetting	Plumb drill hole
Radial well	12–20 ft (4–6 m)	3 ft (1 m) below water bearing formation	Horizontal laterals through wall sleeves into water-bearing formation Concrete plug placed at bottom of caisson	Access greater saturated thickness of the aquifer Reduced number of pumps to be installed and maintained

COMMON CONSTRUCTION COMPONENTS

Reliable information regarding specific geologic materials and aquifer conditions at the site is necessary to establish the optimum design for a production well. The most accurate way to characterize the formations beneath the site is to drill through them, obtaining samples while drilling, and recording the data collected. In addition to the information derived from test-well drilling and test pumping, there are a variety of geophysical logging methods that can provide useful information. The extent and cost of the exploratory and test drilling programs must be balanced against the difficulty in obtaining potable water in a site-specific area, the quantity and quality of the water sought, the use and nature of the well or wells, and the anticipated cost of the permanent well and appurtenances.

Test wells provide hydrogeologic information on aquifers and, if completed with casing and screen, serve as observation wells. Test wells are pumped to provide information

on aquifer properties and water quality. Step-drawdown tests conducted on test wells facilitate the design of production wells by providing information on the amount of water that can be withdrawn, the amount of drawdown that occurs for a given pumping rate, and the recovery time for the aquifer. This allows the hydrogeologist to recommend a pump that will not deplete the aquifer. Because aquifers change throughout the formation, the step-drawdown test requires good aquifer data. Formation samples should be taken at a maximum interval of 10 ft (3.05 m) and at each change of formation. Particular care should be taken when collecting samples from proposed production zones. Collected samples should be dried and preserved in separate containers of at least 1.1-lb (500-g) capacity for each interval. Containers must be clearly marked with well designation, location, depth, sampling method, sampler type, and the date and time the sample was taken. Water samples should be taken for chemical analyses from each aquifer designated as a possible production zone. The method used to collect samples must not contaminate the aquifer. Temperature, pH, and dissolved gases should be measured in the field at the time the samples are taken.

During drilling and completion of the well, the well driller should maintain a complete log of the following as they apply:

1. Reference point (benchmark or other surface datum point) for all depth measurements.
2. Depth at which each change of formation occurs.
3. Depth at which the first water was encountered, when applicable to the drilling method.
4. Location and thickness of each aquifer.
5. Identification of the stratigraphy and lithology encountered in the borehole.
6. Depth interval from which each water and formation sample was taken.
7. Depth for each casing (NOTE: multiple casings with multiple diameters may be used on deeper wells). All data must be collected for each casing set.
8. Depth to the static water level (SWL) and observable changes in SWL with well depth.
9. Total depth of completed well.
10. Location limits of any formation zones where the drilling mud was lost.
11. Depth of the surface or sanitary seal.
12. Nominal hole diameter of the wellbore above and below the casing seal.
13. Quantity, type, and mixture of the grout installed for the seal.
14. Depth, length, diameter, wall thickness, material, and the type of connection of the well casing.
15. Well-screen type, diameter, wall thickness, material, aperture size and orientation, type of connection, and depth interval in the borehole.
16. For gravel-packed wells, the interval, height, thickness, grain size of gravel material used, and the gravel pack to formation grain-size ratio.
17. Capacity of the well, pump installed, and the observed drawdown during testing.
18. Sealing off of water-bearing strata, if any, and the exact location thereof.

Table 5-2 USGS grain-size classification

	Grain-Size Range	
	<i>in.</i>	<i>(mm)</i>
Boulder	≥ 10.08	≥ 256
Cobble	2.52–10.08	64–256
Very coarse gravel	1.26–2.52	32–64
Coarse gravel	0.63–1.26	16–32
Medium gravel	0.31–0.63	8–16
Fine gravel	0.16–0.31	4–8
Granule (very fine gravel)	0.08–0.16	2–4
Very coarse sand	0.04–0.08	1–2
Coarse sand	0.02–0.04	0.5–1
Medium sand	0.01–0.02	0.25–0.5
Fine sand	0.005–0.01	0.125–0.25
Very fine sand	0.002–0.005	0.063–0.125
Silt	0.0002–0.002	0.004–0.063
Clay	< 0.0002	< 0.004

19. Rate of penetration. During the drilling of the hole, a time log shall be maintained showing the rate of penetration, as well as the types of bits used in each portion of the hole.

20. Any and all other pertinent information specified by the purchaser.

A geologist should be hired to prepare a stratigraphic log to accompany the set of drilling samples, noting (1) depth; (2) strata thickness; (3) lithology, including size, range, and shape of constituent particles, as well as smoothness, rock type, and rate of penetration; and (4) such special notes as might be helpful. The description shall conform to the USGS standard gradation of grain sizes shown in Table 5-2 as applicable (rock cuttings would not be classified this way).

Principal aquifers occurring throughout the depth of a well shall be identified using interpretation of results generated by geophysical borehole logging devices. Identification shall be made by a qualified engineer, hydrogeologist, or well constructor. Differentiation of principal aquifers in a well shall be determined on the basis of formation samples obtained.

Material Requirements

All well construction materials shall comply with the requirements of the Safe Drinking Water Act, American Water Works Association (AWWA) and NSF International standards, and other federal and state or provincial regulations for the intended water use.

Drilling fluid materials. Drilling fluids are used in the process of drilling to facilitate the removal of formation cuttings and to stabilize the borehole during drilling and completion operations. The following types of drilling fluids are acceptable for water-well drilling:

1. Freshwater-based drilling fluids.
2. Air-based drilling fluids.

Acceptable additives to drilling fluids are as follows (all should be suitable for potable water use):

1. Dissolved additives
 - a. mud-thinning agents
 - b. surfactants

- c. drilling detergents (nonphosphate)
 - d. foaming agents
 - e. natural and synthetic polymers
2. Nondissolved additives
 - a. bentonite
 - b. density-increasing materials
 - c. loss-circulation materials (not to be used in the production zone)

Casing materials. The well casing is a lining for the drilled hole that maintains the open hole from the land surface to the water-bearing formation. Casings seal out contaminated water from the land surface and undesirable water from formations above the aquifer. For the casing to be entirely effective, it must be constructed of suitable materials and be properly installed so as to be watertight for its entire depth.

Materials commonly used for well casings are alloyed or unalloyed steel, fiberglass (glass-reinforced plastic—GRP), and polyvinyl chloride (PVC). GRP and PVC have been used extensively in recent years for installations in shallow wells (occasionally to several 100 ft), or where corrosion/bacteria may be an issue. In selecting a suitable material, the strain that the casing experiences during installation and the corrosiveness of the water and soil must be considered. All the materials discussed provide satisfactory service given the correct groundwater environment.

The selection of materials is critical for well casing in locations where there is likelihood the well casing will be exposed to significant concentrations of pollutants consisting of low-molecular-weight petroleum products or organic solvents or their vapors. Research has documented that casing materials such as PVC and elastomers, such as those used in jointing gaskets and packing glands, may be subject to permeation by lower-molecular-weight organic solvents or petroleum products. If well casing extends through such a contaminated area or an area subject to contamination, the manufacturer should be consulted regarding permeation of casing materials.

All casing materials must be new and conform to one of the manufacturing standards listed in Table 5-3. A manufacturer's certification of materials shall be provided to the purchaser by the contractor. Steel casings should not be installed if microbiological issues are present. Casings shall meet the minimum diameter requirements given in Table 5-4.

Lighter-weight materials may be used for test wells or temporary casings. Temporary casings are sometimes used as forms when a grout seal is placed around the outside of the permanent casing. The temporary casing is withdrawn as the grout seal is placed. Under such circumstances, lighter and less expensive material can be used.

Joints for permanent steel casings should have threaded couplings or should be welded to ensure watertightness from the bottom of the casing to a point above grade. This precaution will prevent surface contamination or undesirable underground waters above the water-bearing formation from entering the well. Thermoplastic casing is typically of either bell-and-socket construction, joined by cementing, or joined with spline-lock fittings in diameters relevant to water wells (ASTM F-480).

Casing installation. When drilling a well by the cable-tool method, casing should be driven as soon as it becomes necessary to prevent the ground formation from caving. A drive shoe, attached to the lower end of the pipe, keeps the hole from collapsing. Drive shoes are threaded or machined to fit the pipe or casing, and the inside shoulder of the shoe butts against the end of the pipe. Drive shoes are forged of high-carbon steel, without welds, and are hardened at the cutting edge to withstand hard driving.

Casing is driven using drilling tools, drive clamps, and the drive head. A length of casing is attached to the previous length already set. A drive head is attached to the upper

end of the casing to protect it from the driving blows of the drive clamp, which is attached to the drill stem. When the drill is lowered into the length of casing and subsequently raised and lowered, the action of the dropping clamp on the drive head forces the casing into the drill hole.

Wells constructed using rotary methods are not usually cased until drilling is completed. Because the casing is smaller than the drilled hole, no driving is required. In some instances, a casing is installed concurrently with drilling, such as with the use of dual-rotary or cable-tool drilling methods.

Special casing situations. If the formation being penetrated could likely cave equally throughout the full depth of the well, a single casing is usually sufficient. In these situations, the sand and gravel caves in around the outside of the casing and closes the space between the borehole and the casing. Generally grouting the entire length of the casing is preferred.

Table 5-3 Water-well casing materials

A. Manufacturing standards for single-ply carbon-steel well casing:	
ANSI/AWWA C200	
API Spec. 5LX	
ASTM A53 Grade B	
ASTM A139 Grade B	
B. Manufacturing standards for alternative single-ply well-casing materials:	
<u>Casing Material</u>	<u>Manufacturing Standard</u>
Carbon steel	ASTM A139 Grade B
Copper-bearing steel	ASTM A139 Grade B with the additional requirement that the steel contain a minimum of 0.20% copper
High-strength low-alloy steel	ASTM A606 Type 4
Stainless steel	ASTM A778
Plastic	ASTM F480
C. Two-ply steel casing, material properties:	
<u>Chemical Composition, %:</u>	
Carbon	0.20–0.30
Manganese	0.85–1.30
Phosphorous	0.05 maximum
Sulfur	0.05 maximum
Silicon	0.12 maximum
Copper	0.20 minimum
<u>Physical Properties:</u>	
Yield strength, psi (MPa)	55,000–70,000 (379–483)
Ultimate strength, psi (MPa)	80,000–95,000 (552–655)
Elongation, % in 8 in. (200 mm)	17–25
Rockwell “B” harness	80–90
Elastic ratio	69–73

Source: AWWA Standard A100.

Table 5-4 Standard well-casing sizes for wells

Maximum Diameter of Pump Assembly*		Minimum (Actual) Inside Diameter (ID) of Well Casing	
<i>in.</i>	<i>(mm)</i>	<i>in.</i>	<i>(mm)</i>
4	(101.6)	6	(152.4)
5	(127.0)	8	(203.2)
6	(152.4)	10	(254.0)
8	(203.2)	12	(304.8)
10	(254.0)	13	(330.2)
12	(304.8)	14	(355.6)
14	(355.6)	16	(406.4)
16	(406.4)	20	(508.0)
18	(457.2)	22	(558.8)
20	(508.0)	24	(609.6)
22	(558.8)	26	(652.6)

Source: AWWA Standard A100.

* For pumps larger than 22 in. (558.8 mm) in diameter, casing diameter shall be at least two nominal sizes larger than the diameter of the pump being installed.

If additional protection is desired against corrosion and pollution, an outer casing may be installed and the annular space between the casings filled with cement grout. With this type of installation, the outer casing may be either left in place or withdrawn completely. If withdrawn, the grout is placed as the temporary casing is removed. The temporary casing is generally one pipe size larger in diameter than the outside diameter of the couplings of the protective casing (based on Table 5-4). This type of grouted installation may also be used where the water-bearing formation underlies clay, hardpan, or other stable formations.

Where the well penetrates water-bearing rock underlying unconsolidated material, the casing is driven into the rock to obtain a good seat. Unfortunately, a tight seal that will prevent pollution or the unconsolidated material above from entering the well is not guaranteed. One way to obtain additional protection is to drive the casing down to stable rock. The rock is then drilled and under-reamed to a diameter that is 2 in. (50 mm) larger than the outside diameter of the shoe, to a depth of 10 ft (3 m). The under-reamed portion of the drill hole below the bottom of the casing is filled with cement grout, and the casing is driven to the bottom of the hole. Before drilling is resumed, the cement grout is allowed to set for several days, providing a good seal. Drilling is then continued, and the cement grout drilled out. An open, uncased hole is then constructed in the water-bearing rock below this point.

Fractured formations, such as limestone, that are channeled or creviced frequently yield polluted water or water of poorer water quality than desired. These formations should be considered vulnerable to surface contamination and subject to source water protection efforts (see chapter 3) unless overlain with an adequate thickness of unconsolidated formations or a competent layer of low-permeability rock. Under such circumstances, the well can be protected if it is watertight to a depth greater than that of the deepest existing well of questionable construction in the area and substantially below the lowest anticipated water level. The watertight construction is achieved by drilling the hole in the creviced rock that is 2-in. (50-mm) larger than the outside diameter of the casing couplings and by filling the annular space between the drill hole and the outside of the casing with cement grout. In some areas, such construction may not be realistic because available water is cased off.

Casing wall thickness. As specified by the hydrogeologist or engineer, casing wall thickness must be sufficient to withstand anticipated formation and hydrostatic pressures

and mechanical forces imposed on the casing during installation, well development, and use. The minimum wall thickness tables (Tables 5-5 and 5-6) come from AWWA standards and are recommended as the minimum thickness, absent unusual stress, to be placed on the casing in the course of installation, well development, and use.

Selection of casing wall thickness merits analysis and judgment by experienced, qualified engineers and drilling experts. Actual wall thickness should, in each instance, be based on an analysis of the anticipated stresses to which the casing will be subjected during each phase of construction and any pertinent state or local requirements. The collapse strength of the selected casings should be checked during installation and cementing to avoid casing collapse. An appropriate corrosion allowance shall be included.

Screens

Generally, wells completed in unconsolidated formations, such as sands and gravels, are equipped with screens. Screens allow the maximum amount of water from the aquifer to enter the well with a minimum of resistance and prevent sand entering the well during pumping. Screens are occasionally installed in fractured formations because they may collapse into the borehole, and trap pumps and other equipment in the borehole.

Although a screen prevents sand from entering the well during pumping, a screen also allows fine formation particles to enter the well during the development process so they may be removed by bailing. At the same time, the large particles of sand are held back, forming a permeable, graded natural gravel screen around the well screen itself. In this way, the hydraulic conductivity of the water-bearing formation around the well screen is greatly increased, resulting in lower velocity head loss and higher capacity per foot of drawdown.

Table 5-5 Minimum thickness for steel well casing—single casing

Depth of Casing <i>ft (m)</i>	Nominal Casing Diameter— <i>in. (mm)</i>									
	8 (203)	10 (254)	12 (305)	14 (356)	16 (406)	18 (457)	20 (508)	22 (559)	24 (610)	30 (762)
0–100	1/4 (6.35)	1/4 (6.35)	1/4 (6.35)	1/4 (6.35)	1/4 (6.35)	1/4 (6.35)	1/4 (6.35)	5/16 (7.94)	5/16 (7.94)	5/16 (7.94)
100–200	1/4 (6.35)	1/4 (6.35)	1/4 (6.35)	1/4 (6.35)	1/4 (6.35)	1/4 (6.35)	1/4 (6.35)	5/16 (7.94)	5/16 (7.94)	5/16 (7.94)
200–300	1/4 (6.35)	1/4 (6.35)	1/4 (6.35)	1/4 (6.35)	1/4 (6.35)	5/16 (7.94)	5/16 (7.94)	5/16 (7.94)	5/16 (7.94)	3/8 (9.52)
300–400	1/4 (6.35)	1/4 (6.35)	1/4 (6.35)	1/4 (6.35)	5/16 (7.94)	5/16 (7.94)	5/16 (7.94)	5/16 (7.94)	3/8 (9.52)	3/8 (9.52)
400–600	1/4 (6.35)	1/4 (6.35)	1/4 (6.35)	1/4 (6.35)	5/16 (7.94)	5/16 (7.94)	5/16 (7.94)	3/8 (9.52)	3/8 (9.52)	7/16 (11.11)
600–800	1/4 (6.35)	1/4 (6.35)	1/4 (6.35)	5/16 (7.94)	5/16 (7.94)	5/16 (7.94)	3/8 (9.52)	3/8 (9.52)	3/8 (9.52)	7/16 (11.11)
800–1,000	1/4 (6.35)	1/4 (6.35)	1/4 (6.35)	5/16 (7.94)	5/16 (7.94)	5/16 (7.94)	3/8 (9.52)	7/16 (11.11)	7/16 (11.11)	1/2 (12.70)
1,000–1,500	1/4 (6.35)	5/16 (7.94)	5/16 (7.94)	5/16 (7.94)	3/8 (9.52)	3/8 (9.52)	3/8 (9.52)	7/16 (11.11)	*	*
1,500–2,000	1/4 (6.35)	5/16 (7.94)	5/16 (7.94)	5/16 (7.94)	3/8 (9.52)	3/8 (9.52)	7/16 (11.11)	7/16 (11.11)	*	*
(450–600)	(6.35)	(7.94)	(7.94)	(7.94)	(9.52)	(9.52)	(11.11)	(11.11)	—	—

Source: AWWA Standard A100.

NOTE: Tables 5-5 and 5-6 for steel well casings are provided for example purposes. For casing thickness tables for other materials, consult the manufacturer.

Table 5-6 Minimum thickness for two-ply steel well casing

Depth of Casing <i>ft (m)</i>	Diameter— <i>in. (mm)</i>								
	10 (254)	12 (305)	14 (356)	16 (406)	18 (457)	20 (508)	22 (559)	24 (610)	30 (762)
0–100 (0–30)	12 (2.66)	12 (2.66)	12 (2.66)	12 (2.66)	10 (3.42)	10 (3.42)	10 (3.42)	10 (3.42)	8 (4.18)
100–200 (30–60)	12 (2.66)	12 (2.66)	12 (2.66)	10 (3.42)	10 (3.42)	10 (3.42)	10 (3.42)	8 (4.18)	8 (4.18)
200–300 (60–90)	12 (2.66)	12 (2.66)	10 (3.42)	10 (3.42)	10 (3.42)	10 (3.42)	8 (4.18)	8 (4.18)	8 (4.18)
300–400 (90–120)	12 (2.66)	12 (2.66)	10 (3.42)	10 (3.42)	10 (3.42)	8 (4.18)	8 (4.18)	8 (4.18)	8 (4.18)
400–600 (120–180)	10 (3.42)	10 (3.42)	10 (3.42)	10 (3.42)	8 (4.18)	8 (4.18)	8 (4.18)	8 (4.18)	8 (4.18)
600–800 (180–240)	10 (3.42)	10 (3.42)	10 (3.42)	8 (4.18)	8 (4.18)	8 (4.18)	6 (4.94)	6 (4.94)	6 (4.94)
800–1,000 (240–300)	10 (3.42)	8 (4.18)	8 (4.18)	8 (4.18)	8 (4.18)	6 (4.94)	6 (4.94)	6 (4.94)	6 (4.94)

Source: AWWA Standard A100.

* Values are US Standard Steel Thickness Gauge (mm).

Screen selection. Proper screen selection is important in the design of a well drawing on unconsolidated aquifers. Selection is often a complex process matter that demands a highly specialized knowledge of well construction and operation. Consulting a reliable screen manufacturer and experienced geologist is advised. Most manufacturers maintain a screen selection service and will make mechanical analyses of samples and recommend the proper opening.

Slot size. Depending on the type of well construction, the slot size is selected to permit a percentage of the formation material to pass through it. The size of screen openings, or the slot number, is usually expressed in thousandths of an inch as shown in Figure 5-11. The width of the slot, or slot size, is best determined with a mechanical sieve analysis of a sample of the water-bearing formation.

Representative samples of the formation must be selected for mechanical grain-size analyses. A complete descriptive log of the well should be submitted to the screen manufacturer with the samples. Information concerning the well diameter, aquifer thickness, transmissivity or hydraulic conductivity, and the desired well capacity should be included with the log.

A well may be constructed to allow an increase in screen slot size by using a gravel pack. The gravel pack usually consists of pea-rock or other well-graded small stones. When a well screen is surrounded by a gravel pack, the size of the openings is controlled by the size of gravel used and by the types of screen openings as depicted in Figure 5-12. For select gravel-pack well construction, the passage of water through the packing material usually ranges between 10 and 30 percent, depending on the uniformity and gradation of the adjacent formations.

In the past, when casing slots were cut out with a knife or torch, with very little open area, the water slot velocity was of concern. Many regulatory agencies have adopted design criteria for water entrance through the screen opening to be between 0.1 and 0.2 ft/sec (0.03 and 0.06 m/sec). This design criteria promotes more efficient well construction. By contrast, however, research and testing by D.E. Williams for the Roscoe Moss Company found

that the actual head loss across just the thickness of a manufactured well screen, with the percentage of open area equal or greater than the specific yield of the aquifer, was insignificant until the flow-through velocity exceeded 2 ft/sec (0.6 m/sec). The very low screen velocity criteria promoted the use of large-diameter well screens and more efficient well construction. Of greater importance is determining the degree of turbulent flow that will be generated in the water flow through the formation and gravel-pack material surrounding the well screen.

Head was discussed in chapter 4 but is also relevant when designing screens and gravel packs. Turbulent flow head losses around the well borehole increase with the square of this velocity. In laminar flow conditions, the head loss is linear with the velocity. In properly constructed and developed wells of high capacity, the head loss can be quite significant and can cause turbulent flow in the well screen. Turbulent flow causes movement of sand particles and mechanical plugging of the gravel pack, as well as mechanical blockage and chemical precipitation of minerals around the outside of the well screen.

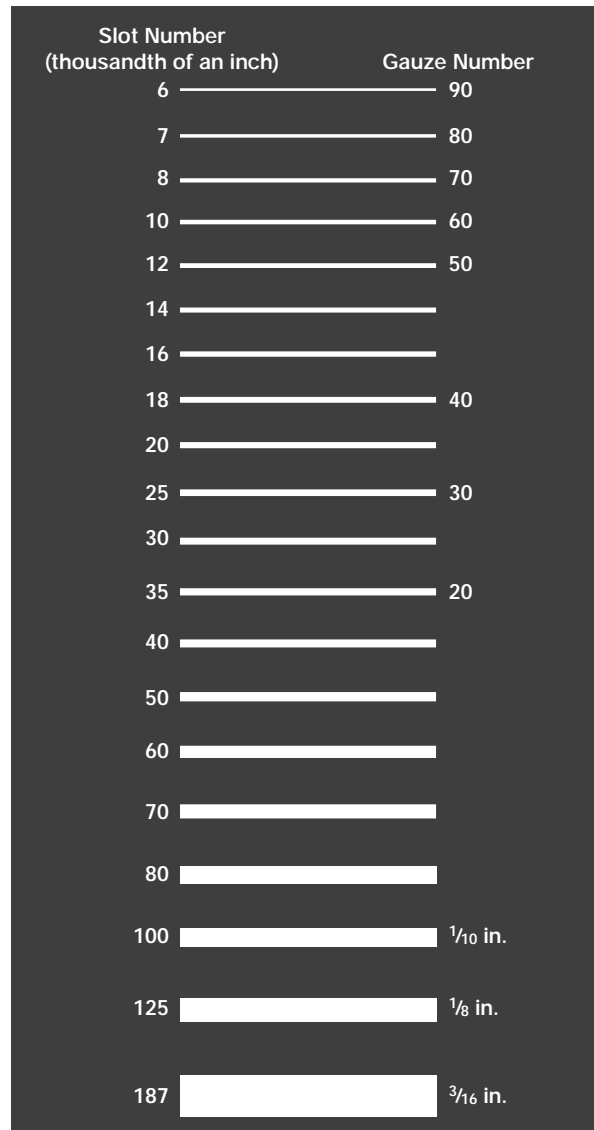
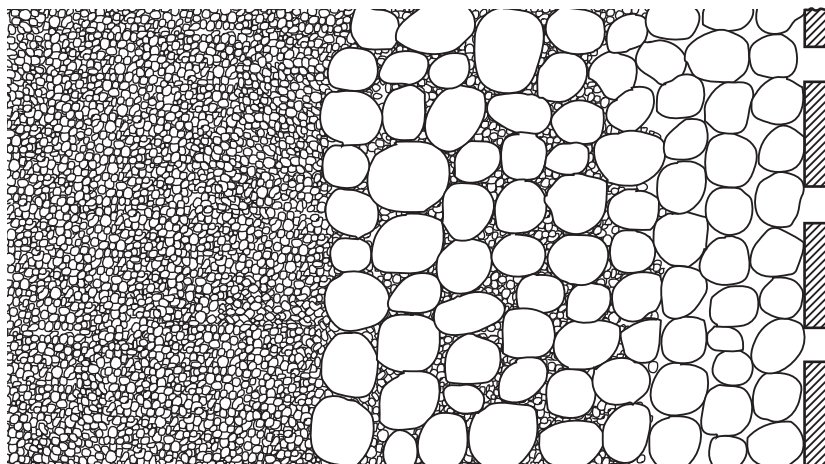
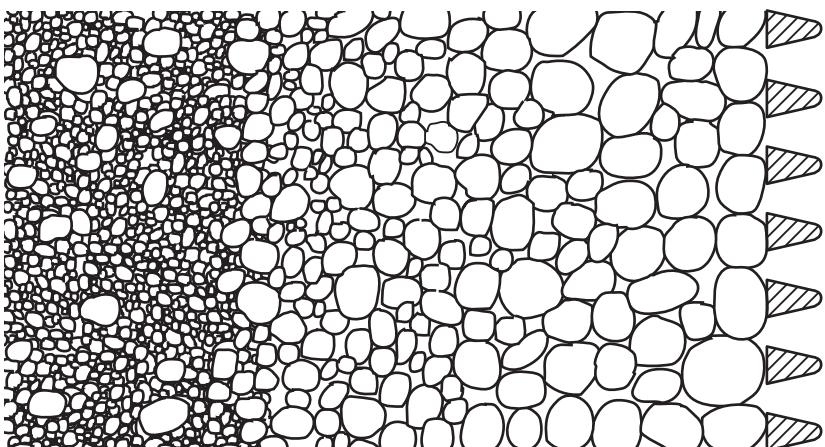

Figure 5-11 Scale of screen-opening sizes



Gravel-wall well



Properly developed drilled well in natural formation

Figure 5-12 Cross-sectional comparison of well walls

Nuzman (1989) accepted that the hydraulic conductivity represents the limit of laminar flow through the formation at a given temperature and viscosity of the water. The limit of laminar flow through the borehole wall could be defined by the following equation:

$$Q = \pi d L k \tag{Eq. 5-1}$$

Where:

- Q = laminar flow
- d = diameter of the borehole
- L = length of screen or thickness of formation
- k = field coefficient of permeability

Converting the units to those commonly used in the field, the equation can be simplified to use the following units:

$$Q_L = \frac{K_g \cdot L_s \cdot D_w}{5,500} \tag{Eq. 5-2}$$

Where:

- Q_L = laminar flow limit in gallons per minute
- K_g = hydraulic conductivity in gpd/ft²
- L_s = length of screen or thickness of formation in feet
- D_w = diameter of the borehole in inches

This equation assumes uniform vertical flow, which does not actually occur in wells. Through field experience, turbulent flow begins through the formation borehole at approximately 2.35 times the laminar flow limit as defined by Eq. 5-2. Again, from field experience, the maximum limits of turbulent flow were found to be approximately 12 times the laminar flow rate as defined by Eq. 5-2.

In the work of Williams (1985), the point where the flow transitions from predominately turbulent flow to predominately laminar flow, assuming a critical Reynolds number of 30, was defined as

$$r_e = 0.9587 \frac{Q/L}{\theta} \quad (\text{Eq. 5-3})$$

Where:

- r_e = critical radius (in.)
- Q/L = specific aquifer discharge (gpm/ft)
- Q = discharge rate (gpm)
- L = length of screen (ft)
- θ = effective porosity

Velocity. Water entrance velocities through the screen openings should be between 0.1 ft/sec and 0.2 ft/sec (0.03 m/sec and 0.06 m/sec). Such velocities will minimize head losses and chemical precipitation. For design of well screens installed in a radial collector well, an average velocity of about 0.033 ft/sec (0.01 m/sec) is used. Screen entrance velocities are computed by

$$V = Q/A \quad (\text{Eq. 5-4})$$

Where:

- V = velocity, in ft/sec
- Q = well capacity, in ft³/sec (1 ft³/sec = 449 gpm)
- A = effective area of screen, in ft²

The effective screen area must be estimated carefully. As much as 50 percent of the screen slots should be assumed to be blocked by particles even after proper well development. The total open area required must be determined by adjusting either the length or diameter of the screen, because the slot is not arbitrary.

Materials. Well screens are available in a wide range of materials, including plastic, mild steel, red brass, bronze, and stainless steel. Selection of a suitable material requires knowledge of soil and water corrosivity, intended use of the well, and anticipated cleaning or redevelopment methods. AWWA Standard A100 gives specific information and specifications for screen selection. To reduce the possibility of corrosion, the well screen and its fittings should be fabricated of the same material. A manufacturer's certification of materials should be provided to the purchaser by the contractor.

Gravel-pack material should generally follow these requirements and impurity limits.

1. *Specific gravity.* The gravel-pack material shall have an average specific gravity of not less than 2.5.

2. *Minimum specific gravity.* Not more than 1 percent, by weight, of the material shall have a specific gravity of 2.25 or less.
3. *Nonround pieces.* Thin, flat, or elongated pieces, the maximum dimension of which exceeds three times the minimum, shall not be in excess of 2 percent, by weight.
4. *Acid solubles.* Not more than 5 percent of the gravel shall be soluble in hydrochloric acid.
5. The material shall be washed and free of shale, mica, clay, dirt, loam, and organic impurities of any kind.

Tests for gradation of gravel-pack material shall be performed according to the method of testing specified in ASTM C136. The ratio of grain size of gravel-pack material to formation material shall range from 6:1 to 4:1. Usually, the 50th or the 70th percentile of the grain sizes retained of both materials is compared. The uniformity coefficient of the gravel pack is typically 2.5.

The minimum thickness to allow for proper placement of gravel-pack material is 3 in. (77 mm), and the maximum gravel-pack thickness usually does not exceed 12 in. (305 mm). Gravel-pack material shall be placed in the annular space adjacent to the well screens and should extend above the screen at least 20 ft (6.10 m), subject to local regulatory requirements.

The selected method for installing gravel pack down-hole should provide a graded envelope of relatively uniform thickness, without segregation or voids, completely filling the annulus within the borehole surrounding the production zone. Gravel packs are installed to maintain the integrity of the borehole to prevent collapse of the aquifer formation materials against the production casing. Gravel pack, properly installed, provides a filter for the formation particles allowing for relatively sand-free water to be pumped from the completed production well. To preserve water quality and prevent contamination of the well, all gravel-pack materials require disinfection with a minimum 50-mg/L free-chlorine strength solution of potable water during installation.

Any of the methods listed, or related variations thereof, may be selected on a site-specific basis suited for the type of well construction used. Each of the methods listed has advantages and disadvantages. More details are provided in the bibliography materials.

A summary of installation methods includes the following:

1. *Poured from surface (shallower wells).* When the assembled casing and screen are centered in the borehole, tubing or drill pipe with two close-fitting swabs can be inserted, one swab located near the bottom of the screen and the other near the surface in the blank casing. Clear water is introduced into the fluid system. The gravel is placed from the surface through the annular space using a funnel or orifice in the annular space between the borehole and casing. Swabbing and circulating is continued during placement until the gravel pack is completely in place.
2. *Pumped with tremie pipe.* When the assembled casing and screen are centered in the borehole, preparations for the installation of gravel pack is performed by pumping through a feed line, or tremie, that extends to the bottom of the casing annulus. The feed line is gradually withdrawn as the filter pack is placed.
3. *Poured from the surface with reverse circulation.* When the assembled casing and screen are centered in the borehole, the return-flow pipe shall be installed with suction near the bottom of the screen. Circulation down the annulus between the casing screen and borehole and back through the return-flow pipe to the surface is started. The velocity of the descending stream should be adjusted to approximately the slip velocity of the particles in the gravel pack.

4. *Pressure pumping.* When the assembled casing and screen are centered in the borehole, the return-flow pipe is installed with suction near the bottom of the screen. The annulus between the return-flow pipe and the casing at the surface is sealed and the filter pack pumped under pressure into the annulus from the surface.

The casing and screen can be installed with a cross-over tool attached to the top of the section and to the drill pipe required for placement. An extension pipe is extended to the bottom of the screen. The gravel pack material is pumped through the drill pipe to the cross-over and into the annulus between the screen and borehole.

Well screen capacity. The physical conditions of aquifers, as well as the experience and practice related to their utilization as groundwater resources, vary between well sites and geographic regions. Historically, a common practice for sizing well screen length and diameter was based on screen open area and inlet velocity (entrance velocity). However, the recommended upper limit for this screen inlet velocity has varied greatly among designers and remains a subject of considerable technical debate. Many designers have, for various technical reasons, limited well screen entrance velocities to 0.1 ft/sec (0.03m/sec) to prevent migration of fines to the well screen. Others have used and demonstrated successful well designs and installations with velocities substantially exceeding 0.1 ft/sec (0.03m/sec). AWWA Standard A100 has previously set this upper limit at 1.5 ft/sec (0.46m/sec); however, velocity depends on the site-specific issues. Subsequent versions of A100 recognize that there is no singular, uniquely defined criterion for permissible velocity through the screen slot openings that is solely suitable for designing a well screen without consideration of the aquifer characteristics and the manner of well construction. In particular, the aspects of flow surrounding the well screen in the aquifer are known to play the primary role in the well's performance.

The diameter of the well screen should be the minimum size that will maintain a vertical velocity within the screen barrel of not greater than 4 ft/sec (1.22m/sec), based on the maximum well flow in gallons per minute specified by the engineer or hydrogeologist. If it is anticipated that the pump setting will be into or below the screen, the minimum inside diameter of the screen shall conform to Table 5-7 (see page 114).

The length of screen most appropriate for the well's construction must be selected with regard to the aquifer's thickness and stratigraphic layering, in addition to the various hydraulic factors affecting a well's performance. Where possible, the portion of the aquifer exposed to the screen should be sufficient to minimize the effects of partial penetration. In unconfined aquifers, the length and position of the screen required to negate partial penetration must be balanced against limiting the available drawdown. Stratigraphic layers varying in coarseness and permeability also may influence the length and position of screen.

Screen apertures, or slot sizes, should be sized according to the following criteria:

1. Where the coefficient of uniformity of the grains of the formation is greater than 6, the screen aperture should be sized to retain 30 to 40 percent of the aquifer sample.
2. Where the uniformity coefficient of the formation is less than 6, the screen aperture shall be sized to retain 40 to 50 percent of the aquifer sample.
3. If the water in the formation is corrosive or the accuracy of the aquifer sample is in doubt, a size should be selected that will retain 10 percent more than is indicated in items 1 and 2.
4. Where fine sand overlies coarse sand, use the fine-sand aperture size for the top 2 ft (0.61 m) of the underlying coarse sand. The coarse-sand aperture size should not be larger than twice the fine-sand aperture size.

5. For gravel-packed wells, the screen-aperture openings should be sized to retain between 80 and 95 percent of gravel-pack material.

Screens should be designed to minimize the possibility of damage during installation, development, and use. Punched or louvered-pipe screen openings must be punched in the casing screens in such a way that no material is removed from the casing wall. The spacing and size of openings should be uniform.

Continuous-slot wire-wound well screens should be fabricated by circumferentially wrapping a triangular-shaped wire around an array of equally spaced rods. Each juncture between the horizontal wire and the vertical rods should be fusion welded underwater for maximum strength. The wire shape must produce inlet slots with sharp outer edges, widening inwardly to minimize clogging. Screen-end fittings should be fabricated of the same material as the screen body to prevent corrosion, and securely welded to each section.

Joints between screen sections and blank casing should be welded or threaded and coupled. If welded, the welding rods should be equivalent to the most noble metal in the well screen. The joint must be water tight, straight, and as strong as the screen.

The screen or screen casing are connected to the well casing by one of the following methods:

1. *Elastomeric seals.* For naturally developed wells, a nonmetallic seal of neoprene or rubber made to fit the casing surrounding the screen should be attached to the screen or screen casing to effect the seal. The screen or screen casing should extend at least 5 ft (1.52 m) into the exterior casing.
2. *Grout seal.* If an elastomeric seal is not used on naturally developed wells, the space between the casing and the formation should be filled with grout to form a seal at least 3 in. (76 mm) thick and 3 ft (0.91 m) in length.
3. *Gravel-pack screen casing seal.* Where the construction of the well is the gravel-packed type, and the screen casing extends at least 50 ft (15.2 m) into the casing above, and the space between the two is filled with gravel, no other seal will be required unless special local conditions warrant it or if it is required by local, state, or federal regulations. When the screen casing does not extend at least 50 ft (15.2 m) into the casing, a grout seal of at least 3 ft (0.91 m) in length should be placed to fill the space between the two casings.

Given that no two wells are exactly the same, placement of the gravel pack should be determined by the hydrogeologist and driller. The gravel-pack materials and the thickness of the gravel pack should be based on all of the information available, including production formation data, well screen, and gravel-pack materials that are practically and economically available. Drillers, hydrogeologists, engineers and others involved in vertical production are urged to consult reference books for more specifics and details than are provided here, such as the National Ground Water Association's* (NGWA's) *Manual of Water Well Construction Practices*, Johnson Screens/Wheelabrator Clean Water's† *Groundwater and Wells*, and Roscoe Moss Company's‡ *Handbook of Ground Water Development*.

Grouting and sealing materials. Water wells are cemented, or grouted, and sealed for the following reasons:

- To protect the water supply against pollution
- To seal out water of an unsatisfactory quality
- To increase the life of the well by protecting the casing against exterior corrosion

* National Ground Water Association, 607 Dempsey Rd., Westerville, OH 43081.

† Johnson Screens, P.O. Box 64118, St. Paul, MN 55164.

‡ Roscoe Moss Company, 4360 Worth St., Los Angeles, CA 90063.

- To stabilize soil or rock formations of a caving nature
- To prevent entry of stormwater runoff around the casing

When a well is drilled, an annular space surrounding the casing is normally, and sometimes purposely, produced. Unless this space is sealed, a channel exists for the downward movement of water. In loose caving formations such as sand, the opening is usually self-sealing. In clay or other stable formations, this space must be cemented to prevent contamination from the land surface or creviced formations connecting with the surface.

When formations located below the depth of the protective casing are known to yield water of an unsatisfactory quality, such formations may be sealed off with liners set in cement grout for their entire length, which may be as much as several hundred feet deep. When a casing is extended to a consolidated formation lying below an unconsolidated formation, the best way to prevent sand or silt from entering the well at the bottom of the casing is by under-reaming and cementing. Under-reaming is used in rotary excavation methods to increase the base-bearing capacity of the piles. The casing exterior is protected against corrosion by encasing it in cement grout, as described previously in the section on casing installation. A minimum grout thickness of 2 in. (50 mm) is recommended and may even be required by some regulatory agencies.

Materials. Materials used for cementing wells should facilitate proper placement and assume a permanent and durable form. Portland-cement grout, properly prepared and handled, meets these requirements adequately.

Proper preparation of the grout mixture is very important. Best results are obtained from neat cement and water mixed in the ratio of one 94-lb (42.6-kg) bag of cement to not more than 5½ gal (20 L) of clean water. Under certain conditions, other materials may be used to accelerate or retard the time of setting, to lubricate the grout mixture, and to provide binders for sealing large crevices. A minimum of 2 percent, and a not-to-exceed maximum of 5 percent, by weight, of bentonite clay should be added to neat cement grout to compensate for shrinkage. Regardless of the materials used, cement, additives, and water must be mixed thoroughly.

The following are commonly used for sealing wells:

1. Neat cement. Neat cement should consist of a mixture of API Spec. 10, Class A (similar to ASTM C150, type 1) or Class B (similar to ASTM C150, type 2) and water in the ratio of not more than 6.0 gal (22.8 L) of water per 94-lb (42.6-kg) sack of cement weighing approximately 118 lb/ft³ (1,880kg/m³). A maximum of 6 percent, by weight, bentonite, and 2 percent, by weight, calcium chloride may be added.
2. Bentonite grout. Bentonite grout should consist of a high-solids bentonite grout and water mixture with a minimum of 20 percent solids, mixed and placed in accordance with the manufacturer's written instructions. Conventional bentonite drilling clay and water mixtures are not allowed.
3. Concrete. Concrete should contain 5.3 sacks of ASTM C150, type 1 or 2 Portland cement per yd³ (0.76 m³) of concrete and a maximum of 7 gal (26.5 L) of water per 94-lb (42.6-kg) sack of cement. The maximum slump should not exceed 4 in. (102 mm). The aggregate should consist of 47 percent sand and 53 percent coarse aggregate, conforming to ASTM C33. The maximum size aggregate should be 0.75 in. (19 mm). Concrete should not be placed in an annular space having a radial thickness of less than 3 in. (76 mm).
4. Sand-cement grouts consist of a mixture of ASTM C150, type 2 cement, sand, and water in the proportion of not more than 2 parts, by weight, of sand to 1 part

of cement with not more than 6 gal (22.7 L) of water per 94-lb (42.6-kg) sack of cement.

Neat cement and bentonite are the most common grouts used. These are discussed further in the following sections.

Bentonite-based grout mixtures. Bentonite grout mixtures (NGWA 1998) have a number of favorable characteristics including:

1. Bentonite, unlike cement-based mixtures, remains plastic when installed as a grout as long as it does not dry out, and can be rehydrated if it does dry. High-active-solids bentonite seals do not crack or separate from surfaces. Low solids (or low-active solids) slurries will crack and separate in the vadose or unsaturated zone.
2. Plastic, hydrated bentonite expands to fill voids, displacing air or water and other fluids.
3. When properly prepared and emplaced, bentonite grout seals have hydraulic conductivities of 10^{-6} cm/sec or less, and reportedly as low as 10^{-12} cm/sec. This very wide range is a result of such variables as placement method (and skill), bentonite type used, conditions of the solids in the mixture, and the environment into which the seal is placed.
4. Bentonite does not generate the heat of hydration experienced with cement, especially with larger annular radii (>2 in.).

Solids content and type. The amount of shrinkage is controlled by the bentonite grout's solids content; with bentonites that have high-reactive solids, content shrinking is far less than with low-solids types used in drilling fluid mixtures. Granular high-solids grades also have more dimensional stability than low-solids slurries (similar in some respects to the difference between neat cement and concrete). For these reasons, high-solids bentonites should be used instead of drilling mud bentonite for borehole sealing applications.

Bentonite solids are more desirable than other solids. Unlike concrete, the preferable solids in bentonite are clays that provide the bulk and dimensional stability (keeping the seal shape and size) in the bentonite gel matrix without increasing the permeability. Rock cuttings and sand have higher specific gravities than bentonite and tend to separate and sink in the hole. However, sand-dry bentonite mixtures (50:50) provide good stiff seals if emplaced so that separation is minimized (i.e., mixed in after the pump discharge and rapidly emplaced) and solids permitted to hydrate down hole.

Bentonite grouts may shrink if moisture is lost. The presence of saline groundwater, strong acids or bases, or some organic compounds in contaminated groundwater may also cause desiccation and shrinkage. At times, a more stiff "set" is preferred than can be provided by bentonite alone, which is plastic and somewhat compressible. Cement is sometimes recommended to be added to a primarily bentonite mixture to provide a stiffer finished product. However, cement constituents can destroy the sealing properties of sodium bentonites. The trade-off for stiffness is generally in the form of a more brittle, more permeable seal. Calcium ions in the cement replace sodium ions by ion exchange, resulting in the clay particles settling closer together. On contact, the calcium ions link the platelets, causing flocculation. These changes are permanent once they are made.

In practice, major problems with cement addition to bentonite seals are the formation of cracks and failure to establish a seal with casing surfaces. This accounts for the generally higher permeability and may cause long paths of migration. For a stiffer, solid set, it is preferable to mix and place a very high-solids bentonite or bentonite-and-sand mixture, instead of adding cement. Mixing water quality should be fresh (not saline) and

approximately of drinking water quality in total dissolved solids and calcium ion content. The water should be sanitary and free of foreign objects.

The grout must be applied in one continuous operation to assure a satisfactory seal and be entirely in place before the initial set. The grout must always be introduced at the bottom of the space to be grouted to avoid segregation of materials, inclusion of foreign materials, or bridging of the grout mixture, and if above the fluid level, to avoid leaving large pockets of air in the annulus.

Neat cement grout mixtures. Neat cement uses Portland cement as the hardening ingredient. Portland cement is composed of powdered calcium silicate obtained from limestone and shale that hardens when water is added. Neat cement grout sets quickly and consists of a mix of 6 gal of water per 94-lb sack of rapid-curing Type III Portland cement. To make neat cement grout less permeable and reduce shrinkage, less water is used. Bentonite is used to increase the bulk of neat cement grout as it dries.

Neat cement grout swells less and shrinks more than bentonite grout, but it hardens more quickly and solidly. Neat cement grout is better than bentonite grout for sealing small openings and the space around rocks and drill casings. It is also better for sealing artesian wells. Neat cement grout should not be used with plastic casing because of the heat produced by the curing cement.

Placing grout. Various methods are used for placing grout, including the dump-bailer method, air or water pressure drive, and pumping. Other proprietary methods of grouting, not discussed in this manual, are used by well cementing companies. There are six ways to place grout. These are:

1. The *dump-bailer method* is perhaps the simplest. The cement grout is lowered in a dump bailer that discharges its load when it reaches the bottom of the hole. After the necessary amount of grout is placed in the well, the casing is pulled up far enough so that the shoe is above the grout. A plug is placed in the bottom of the casing, which is then driven to the bottom of the hole, displacing the grout into the annular space around the outside of the casing.
2. *Tremie method* (most common). Grout material must be placed by tremie pouring (after water or other drilling fluid has been circulated in the annular space sufficient to clear obstructions). When making a tremie pour, the tremie pipe is lowered to the bottom of the zone being grouted and raised slowly as the grout material is introduced. The tremie pipe must be kept full continuously from start to finish of the grouting procedure, and the discharge end of the tremie pipe shall be continuously submerged in the grout, until the zone to be grouted is completely filled.
3. *Positive displacement.* Grout material is placed by the positive-displacement method, after water or other drilling fluid has been circulated in the annular space sufficient to clear obstructions. Grout is injected in the annular space between the inner casing and either the outer casing or the borehole. The grout pipe shall extend from the surface to the bottom of the zone to be grouted. Grout is placed bottom to top, in one continuous operation. The tremie pipe is raised as the grout is poured, but at all times the discharge end of the grout pipe must remain submerged in the emplaced grout until grouting is completed. The grout pipe also must be maintained full until grouting is completed in the entire specified zone.
4. *Interior method without plug.* By this method, grout is placed in the annulus by forcing the grout down a drop pipe that is installed inside the casing, out the bottom of the casing, and then up to the ground surface outside the casing. The drop pipe extends, airtight, through a sealed cap on the casing head of the well casing to a point no more than 5 ft (1.52 m) above the bottom of the casing. The casing head

must be equipped with a relief valve, and the drop pipe equipped at the top with a valve permitting injection of water and grout. The lower end of the drop pipe and the casing remain open. Clean water is injected down the drop pipe until it returns through the casing-head relief valve. The relief valve is then closed, and the injection of water is continued until it flows from the borehole outside of the casing. Sufficient circulation must be established in the annular space to clear obstructions. Without significant interruption, grout is substituted for water and injected, in a continuous manner, down the drop pipe until it returns to the surface outside of the casing. The minimum amount of water necessary should be injected into the drop pipe to flush the grout from it. The valve on top of the drop pipe is closed and a constant pressure maintained on the inside of the drop pipe and casing for at least 24 hr, or until the grout has set.

5. *Positive displacement/drillable plug.* For this method, grout is placed in the annulus through the casing interior (after water or other drilling fluid has been circulated in the annular space sufficient to clear obstructions). A measured quantity of grout, 30 percent in excess of the theoretical volume of the annulus, should be pumped into the capped casing. The casing is left uncapped, a drillable plug inserted on top of the grout, and then the casing is recapped. A measured volume of water, equal to the volume of the casing, is pumped into the casing, forcing the plug to the bottom of the casing and the grout into the annular space surrounding the casing. Pressure is maintained until a sample of the grout indicates a satisfactory set.
6. *Positive displacement through float shoe.* Grout is placed through a drillable float shoe attached to the bottom of the casing (after water or other drilling fluid has been circulated in the annular space sufficient to clear obstructions). Tubing or pipe is run to the float shoe and connected by a bayonet fitting, left-hand thread coupling, or similar release mechanism. Water or other drilling fluid is circulated through the tubing and up through the annular space outside the casing. When the annular space has been flushed, grout is pumped into the annular space surrounding the casing. Pumping should continue until the entire zone to be grouted is filled. Pressure should be maintained until initial set.

Measuring Drill Alignment

All wells should be installed as plumb as possible (except directional drills). As technology has advanced, new methods of checking plumbness and alignment become available, such as gyroscopic or laser methods. Most of these are offered through specialist service companies. However, other methods are available. The alternate-alignment tolerance method is a straightforward, elementary method that is easy to perform in the field. The procedure involves lowering a cylindrical plummet (see Figure 5-13) into the well to the specified depth over which plumbness is to be measured.

The plummet is a rigid spindle with plates on both ends. The outer diameter of the end plates is typically 0.5 in. (13 mm) smaller than the inside diameter of that part of the casing or borehole being tested. The distance between end plates is typically 1.25 times the diameter of that part of the casing or borehole being tested, and heavy enough to keep the plumb-line taut. The plumb line is attached to the plummet at the exact center of the top end plate and shall be of uniform diameter. The other end of the plumb line is attached through an apex on a drill rig, run through a pulley, and attached to a reel (see Figure 5-14) and apex rig. The apex is stationary with a recommended minimum height of 10 ft (3.05 m) above the casing or borehole.

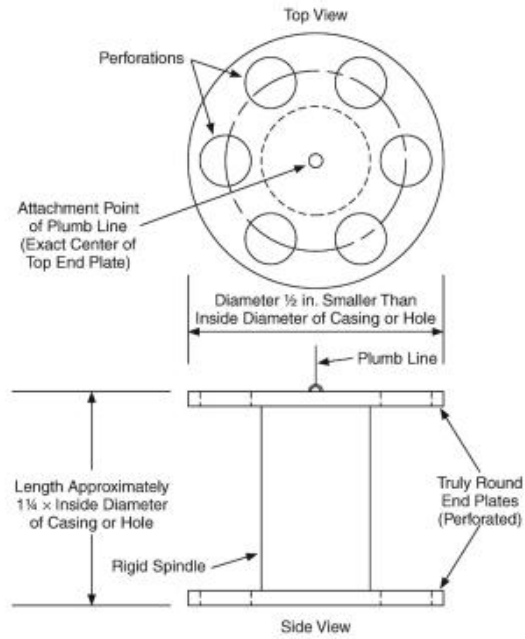

Source: AWWA Standard A-100

Figure 5-13 Details of cylindrical plummet

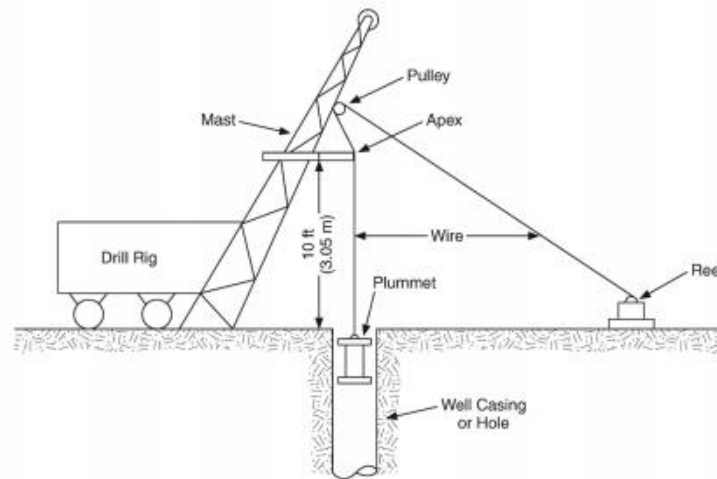

Source: AWWA Standard A-100

Figure 5-14 Suspension of the plummet using drill rig

The pulley needs to be suitable for running the plumb line and plummet. Plumbness and alignment are determined by lowering the plummet a maximum of 10 ft (3.05 m) at a time, or more frequently when approaching the allowable maximum, and measuring the horizontal deflection of the plumb line from the center of the top of the casing or borehole at each interval. The horizontal deflections are measured in two planes, 90° from each other.

The drift (horizontal deviation) of the casing or hole at each recorded depth is calculated using the following formula:

$$\text{drift} = \frac{\text{deflection (height + depth)}}{\text{height}} \tag{Eq. 5-5}$$

Where:

- drift = calculated horizontal deviation of casing or hole from the vertical, in. (mm)
- deflection = measured horizontal deflection of the plumb line from center of the top of casing or hole, in. (mm)
- height = height of apex above the top of casing or hole, in ft (m)
- depth = depth of plummet below the top of casing or hole, in ft (m)

The calculated drift of the casing or hole at the depth intervals recorded in Figure 5-15 should be used to create the calculated drift graphs. The calculated drift of the well at the recorded depth intervals are plotted on cross-section paper in two planes, 90° from each other, as shown in Figure 5-16. First, the calculated horizontal deviations are plotted in one plane, called the *north-south plane*, and then plotted in the other plane 90° from the first, called the *east-west plane*. The lines obtained by connecting the plotted points represent the actual well centerline in each plane.

The following should be provided by the driller as a means to verify well plumbness and alignment:

1. Test sheet—written statement covering details of the plumbness and alignment test data (Table 5-7)
2. Well diagram—longitudinal projections of actual well centerline and proposed pump centerline (see Figure 5-15).
3. Plumbness graph—calculated drift of the well-casing centerline from vertical (see Figure 5-16)
4. Alignment graph—horizontal deviations of actual well-casing centerline from proposed pump centerline (see Figure 5-17).
5. Diagram—a diagram showing the effective well diameter and the determination of the largest pump that can be inserted into the well without bending (see Figure 5-18).

Table 5-7 Plumbness and alignment test data sheet

Details of Plumbness and Alignment Test									
Well No. 1 Date: 3-21-75									
Size of Hole or Casing = 19 ¼ in., ID; Size of Plummet = 18 ¾ in., OD;									
Height of Apex Above Top of Well = 10.0 ft									
Depth of Plummet Below Top of Well	Horizontal Deflection of Plumb Line—ft				Calculated Drift of Well—ft				
	ft	North	South	East	West	North	South	East	West
10	0.010			0	0.0000	0.020		0	0.0000
20	0.100				0.010	0.030			0.030
30	0.010				0.015	0.040			0.060
40	0.010				0.015	0.050			0.075
50	0.010				0.015	0.060			0.090
60	0.005				0.015	0.350			0.105

Source: AWWA Standard A100.

(Table continued next page)

Table 5-7 Plumbness and alignment test data sheet (continued)

Details of Plumbness and Alignment Test									
Well No. 1 Date: 3-21-75									
Size of Hole or Casing = 19 ¼ in., ID; Size of Plumbmet = 18 ¾ in., OD;									
Height of Apex Above Top of Well = 10.0 ft									
Depth of Plumbmet Below Top of Well	Horizontal Deflection of Plumb Line—ft				Calculated Drift of Well—ft				
	ft	North	South	East	West	North	South	East	West
70	0.005				0.015	0.040			0.120
80	0.005				0.020	0.045			0.180
90	0.005				0.020	0.050			0.200
100	0.005				0.020	0.055			0.220
110	0.005				0.010	0.060			0.120
120	0.005				0.010	0.065			0.130
130	0	0			0.005	0	0		0.070
140		0.005	0	0	0	0.075	0	0	
150		0.010	0	0	0	0.160	0	0	
160		0.010			0.005	0.170			0.085
170		0.010			0.005	0.180			0.090
180		0.010			0.010	0.190			0.190
190		0.010			0.010	0.200			0.200
200		0.010			0.010	0.210			0.210

Source: AWWA Standard A100.

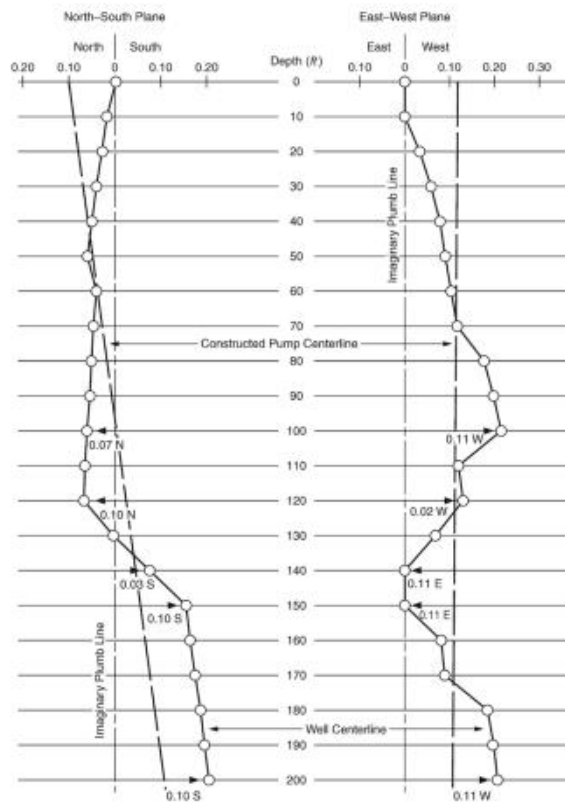

Source: AWWA Standard A100

Figure 5-15 Longitudinal projections of wall and constructed pump centerlines on north-south and east-west vertical planes

AWWA Manual M21

Drift is Greatest at Depths 100 ft and 200 ft

Depth ft	Actual Drift in.	Allowed Drift* in.
100	2.75	12.83
200	3.63	25.66

*For 19.250-in. ID casing.

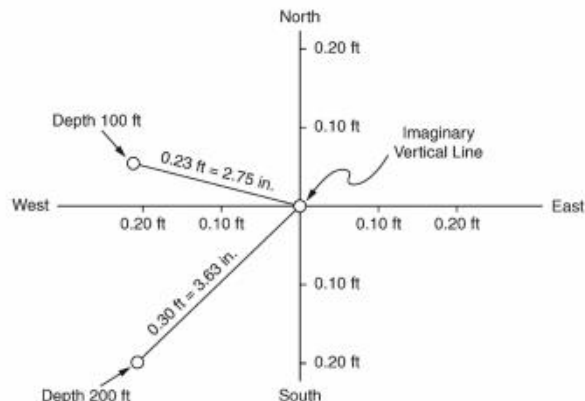

NOTE: This well meets the specifications for plumbness.

Source: AWWA Standard A100

Figure 5-16 Graphic representation of requirements of plumbness in Figure 5-15

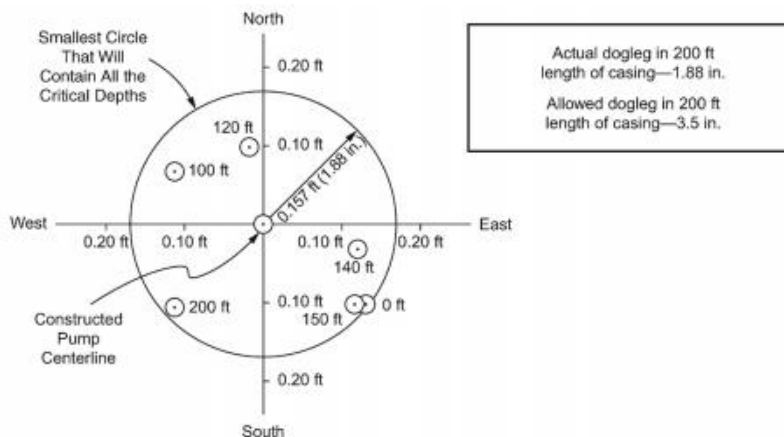

Vertical alignment specification for 19.250-in. ID casing and 12.25-in. OD pump:

Maximum allowable horizontal distance between the actual well centerline and a straight line representing the pump centerline, this line being constructed so as to minimize the horizontal distance between the two centerlines, shall not exceed 3.5 in. (one half the difference between the ID of that part of the well being tested—19.250 in.—and the desired maximum OD of the pump—12.25 in.: $19.250 - 12.25 = 7.0$, one half of 7.0 equals 3.5).

Misalignment Radius = 1.88 in.

This value is the maximum horizontal distance between well centerline and a straight line representing the pump centerline. This line being constructed so as to minimize the horizontal distance between the two centerlines. This value can be considered a measurement of the maximum dogleg of the well.

Misalignment Diameter = 3.76 in.

This value, which is twice the misalignment radius, represents the difference between well ID and the largest pump OD that can be inserted into the well without bending. This value can be considered a measurement of the loss in effective diameter of the well.

Source: AWWA Standard A100

Figure 5-17 Graphic representation of requirements for alignment in Figure 5-15

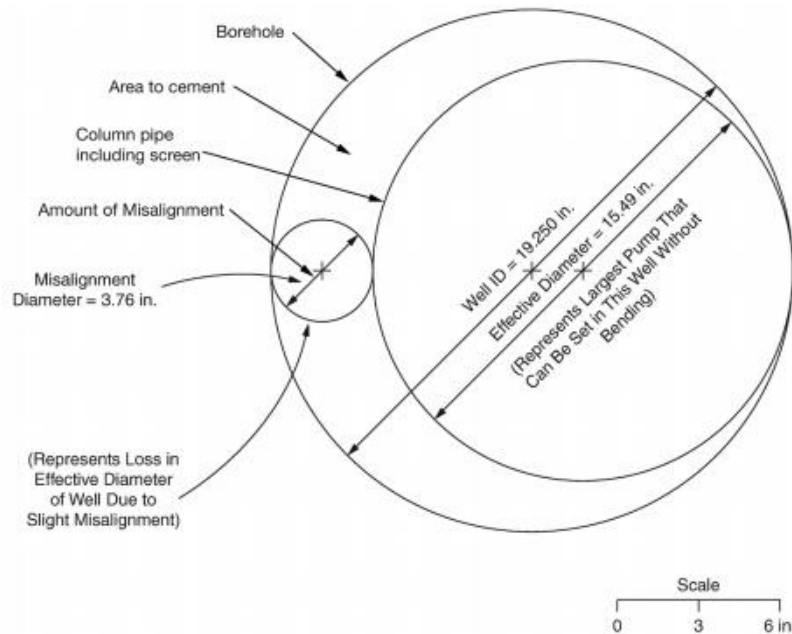

Source: AWWA Standard A100

Figure 5-18 Relationship between misalignment diameter from Figure 5-15, effective diameter of the well, and inside diameter of the well

Well Completion Types

Materials selected for well completion should be designed to meet longevity requirements for the specific environment. As a result there are several kinds of well completion types that can be considered. The well types and those shown in Figures 5-19 through 5-30 are not presented in any order of preference and are not the only types of wells that may be used. The type of well selected must be site-specific and will depend on the intended use, capacity, pump requirements, available aquifers, local and state rules and requirements, and drilling techniques locally available. It is also possible to combine more than one type in a single well. All figures are from AWWA Standard A100.

Type 1 (Figure 5-19) Gravel-packed well with conduct or casing grouted in place and gravel envelope extending to surface.

Type 2 (Figure 5-20) Gravel-packed well with well casing cemented in place and gravel envelope terminated above the top of the screen with gravel feed line.

Type 3 (Figure 5-21) Gravel-packed well with telescoped screen, well casing cemented in place, and gravel envelope terminated above the top of the screen.

Type 4 (Figure 5-22) Naturally developed well with telescoped screen, well pump-housing casing driven or jacked into place, and the conductor sealed as locally required.

Type 5 (Figure 5-23) Naturally developed well with telescoped screen, temporary casing driven or jacked into place, and pump-housing casing sealed in to prevent contamination.

Type 6 (Figure 5-24) Naturally developed well with well casing advanced by driving or jacking and perforated in place.

Type 7 (Figure 5-25) Gravel-packed well with under-reamed borehole for screen and pump-housing casing cemented in place.

Type 8 (Figure 5-26) Gravel-packed well with under-reamed borehole for screens in multiple unconsolidated aquifers.

Type 9 (Figure 5-27) Well with open-hole completion in consolidated rock and well casing cemented in place.

Type 10 (Figure 5-28) Gravel-packed well completed in consolidated rock with well casing cemented in place.

Type 11 (Figure 5-29) Open-hole or screened well completion in an artesian aquifer where piezometric level is above the ground elevation.

Type 12 (Figure 5-30) Naturally developed well with screen and well casing installed in place in an open hole. Blank casing in nonwater-bearing formation is optional.

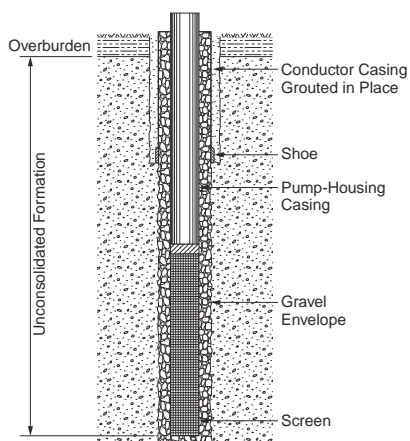

Gravel-packed well with conductor casing grouted in place and gravel envelope extending to surface.

Figure 5-19 Type 1

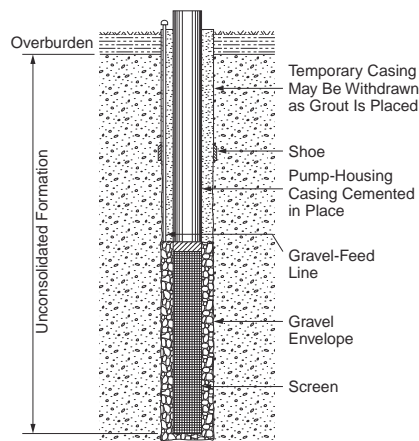

Gravel-packed well with well casing cemented in place and gravel envelope terminated above the top of the screen with gravel feed line.

Figure 5-20 Type 2

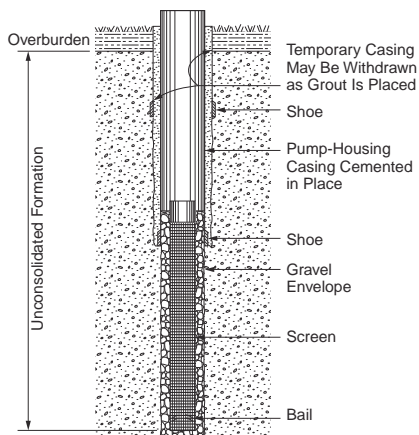

Gravel-packed well with telescoped screen, well casing cemented in place, and gravel envelope terminated above the top of screen.

Figure 5-21 Type 3

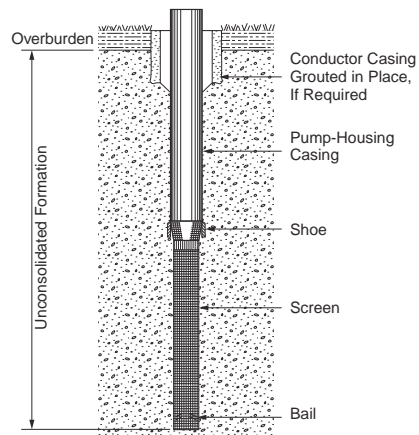

Naturally developed well with telescoped screen, well pump-housing casing driven or jacked into place, and the conductor sealed as locally required.

Figure 5-22 Type 4

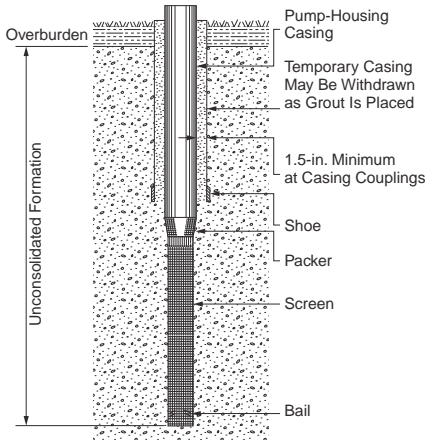

Naturally developed well with telescoped screen, temporary casing driven or jacked into place, and the pump-housing casing sealed in to prevent contamination.

Figure 5-23 Type 5

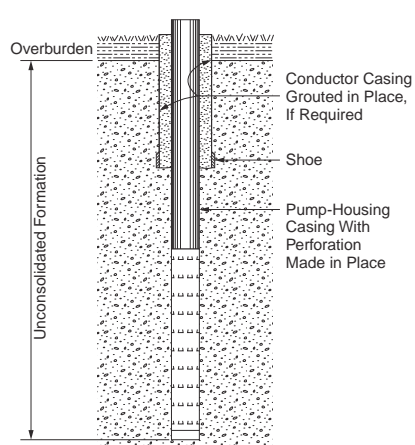

Naturally developed well with well casing advanced by driving or jacking and perforated in place.

Figure 5-24 Type 6

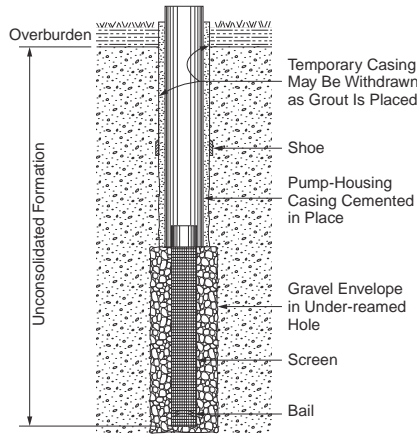

Gravel-packed well with under-reamed borehole for screen and pump-housing casing cemented in place.

Figure 5-25 Type 7

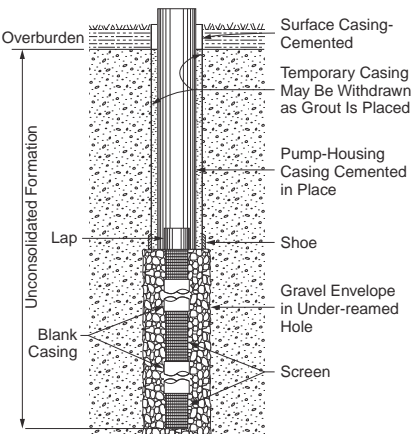

Gravel-packed well with under-reamed borehole for screens in multiple unconsolidated aquifers.

Figure 5-26 Type 8

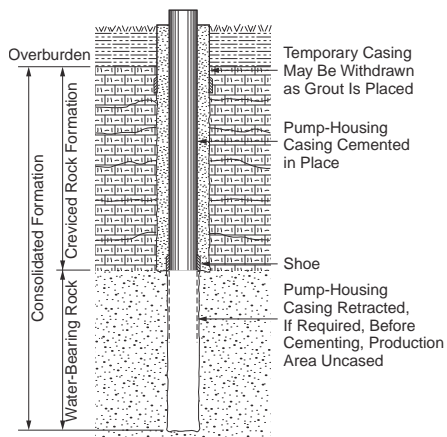

Well with open hole completion in consolidated rock and well casing cemented in place.

Figure 5-27 Type 9

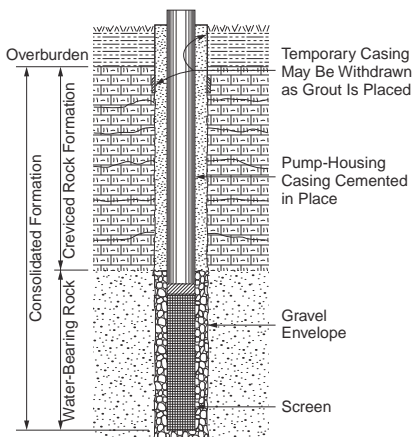

Gravel-packed well completed in consolidated rock with well casing cemented in place.

Figure 5-28 Type 10

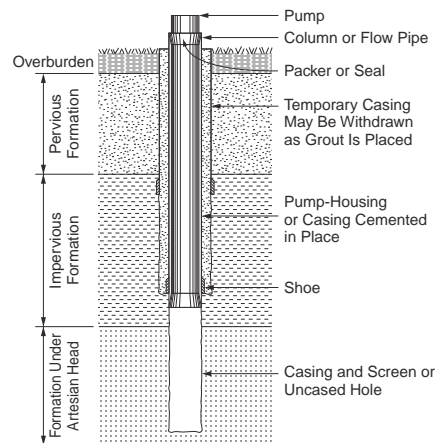

Open hole or screened well completion in an artesian aquifer where the piezometric level is above the ground elevation.

Figure 5-29 Type 11

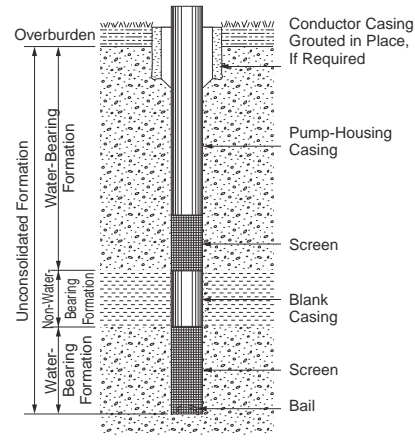

Naturally developed well with screen and casing installed in place in an open hole. Blank casing in non-water-bearing formation is optional.

Figure 5-30 Type 12

Well Development

A variety of methods can be applied for preliminary development of wells, including such commonly used techniques as bailing, surging, flushing, pumping, jetting, and air lifting. Following the use of one or more of these preliminary methods, a well pump should be used for final development and for testing development.

The pump and prime movers should have a capacity in excess of the anticipated lift and final production capacity of the well. The pump should be set to a depth in excess of the anticipated pumping level. The development equipment and method used should permit variable pumping discharge rates.

The discharge piping provided should be of sufficient diameter and length to conduct water to a point designated by the engineer or hydrologist, and should include orifices, meters, or other devices that will accurately measure the discharge rate. The discharge piping should also include a valve or other appropriate device for controlling or regulating the discharge rate. The device used to measure the pump discharge rate shall have a minimum accuracy of 95 percent.

During well development, water elevations in the wells must be measured to the accuracy specified by the engineer or hydrologist. Sand content should also be measured with a sand separator. The installation of the sampler should be according to Figure 5-31.

Complete records of all development work should be maintained. For gravel-pack wells, the quantity of gravel added during development must be recorded. In addition, the following data should also be recorded:

1. Quantity and description of material brought into the well
2. Static and pumping water levels
3. Methods of measurement
4. Duration of each operation
5. Observation of results
6. Pump discharge rates and specific capacity
7. Sand content as a function of pump discharge rate and time

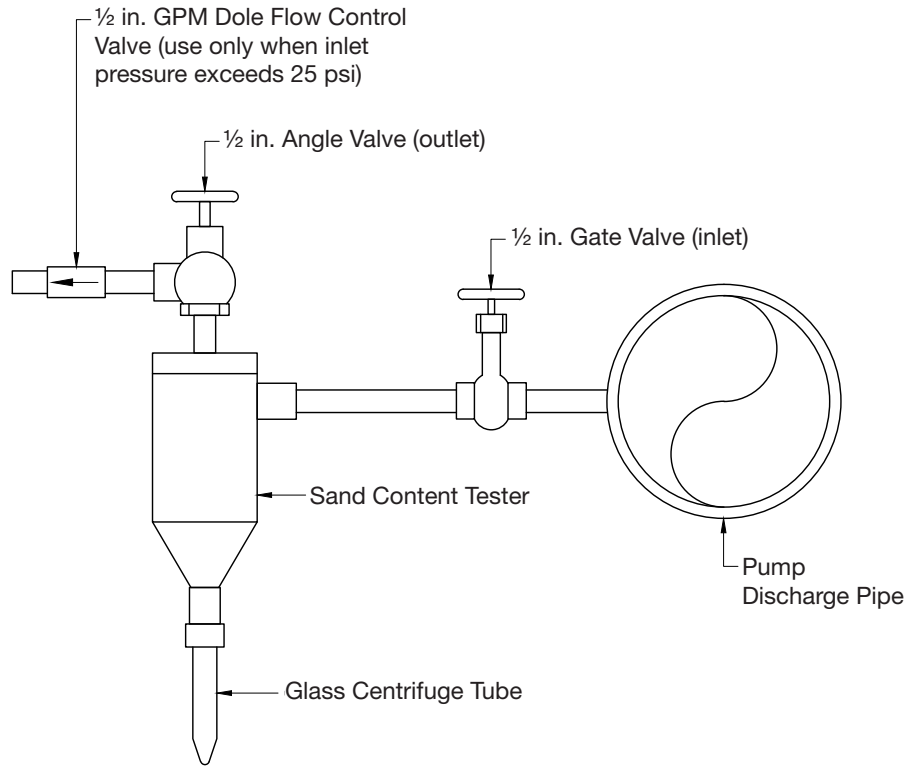

Figure 5-31 Rossum sand sampler

8. Sand content as a function of pump discharge rates and specific capacity
9. Any other pertinent information

During development, a step-drawdown test should be conducted to characterize well performance at varying rates and to determine the general parameters for a constant-rate pumping test. The well shall be pumped at a minimum of at least three progressively increasing rates, and the length of each discharge step should be long enough to indicate a straight-line trend on a plot of drawdown versus logarithm of time from when pumping began.

After the step-drawdown test, the well should be allowed to recover until water levels return to approximately static conditions. After recovery, a constant-rate test should be conducted at a designated capacity to determine the trend of drawdown versus prolonged time of pumping at the pumped well and any observation wells.

Recovery time of the pumping well and any observation wells to be used in the test should be such that a straight-line trend is observed in all of the wells on a plot of water level versus the logarithm of time from when pumping stopped.

Water-level measurements should be obtained before, during, and after the pumping test in order to acquire background information (static water levels), the effects of pumping (pumping water levels), and a profile of the recovery of the water level from the pumping level to the original state. The measurement frequency of water levels during pumping should be adequate to create the drawdown curve.

WELL DESIGN PROCEDURE

The well design procedure starts with some expectations of potential water yield from an aquifer. With many uncertainties, a small-diameter test well should be constructed to ascertain the depth and thickness of the aquifer, a pumping test should be conducted and the data analyzed to determine the transmissivity and hydraulic conductivity, and the water quality should be determined to be satisfactory or if treatment is needed. Typically, the client has a need for a specific water yield, and the well designer must bring these inputs together to design a cost-effective and efficient well.

It is often convenient to start with the well screen diameter, which should be at least one pipe size larger than the largest diameter of the pumping equipment to be installed. If a shroud needs to be installed around a submersible pump and motor, then appropriate allowance in diameter needs to be made. If additional equipment is to be installed such as a transducer or water level controls, an increase of two pipe size diameters may be needed.

If gravel-pack construction is to be used, the borehole should meet minimum thickness requirements of 4 in. (16 mm) as specified in AWWA Standard A100. The purpose of the laminar flow limit equation (Eq. 5-2) is to help select an appropriate borehole diameter for the well construction procedure to be used. If the average hydraulic conductivity, length of well screen and minimum borehole diameter, and the limit of borehole diameter are input, the limit of laminar flow can quickly be calculated. This value may appear to be very low, but most high-capacity wells are operated in the turbulent flow range. Typically, a flow yield of approximately 4 to 6 times the laminar flow rate will be cost-effective. The gravel-pack thickness can be increased to the available yield. Unfortunately, in low-permeability aquifers, the maximum practical well borehole diameter will limit the water yield. Other limitations such as saturated thickness, available drawdown, and static water level depths affect the available yield.

SANITARY PROTECTION

All water supply wells must be provided with adequate sanitary protection through proper construction and disinfection. This includes bentonite seals and protection against surface flooding.

Disinfection

During the process of well construction, the drill hole is subject to contamination from the land surface. Contamination can also be introduced by tools, drilling mud (in the case of the rotary method), the casing, and the screen. Normally, extended pumping would rid the well of this contamination; however, disinfecting the well with chlorine is faster.

Many disinfection methods are available and should be selected by the engineer supervising the installation. As a general rule, sufficient chlorine must be thoroughly mixed with the water in the well casing to produce a concentration of at least 50 mg/L in the well when the disinfectant is pumped into the well. This solution must come in contact with the pump and discharge piping. Disinfection is achieved by adding chlorine in the casing and producing a mix by alternately starting and stopping the pump or by other methods. Contact time is a minimum of 24 hr.

The material used for gravel treatment, even though washed and clean, still carries contamination. Therefore, gravel-wall wells are sometimes difficult to disinfect following construction. In addition to the procedures outlined for disinfection, a tablet or powdered calcium hypochlorite can be occasionally added by hand to the gravel filling tube as the gravel is placed.

Even with disinfection, the water pumped from a well may still show evidence of contamination. Under such circumstances, a chlorinator can be installed at the well to treat all the water discharged to the system. In time (perhaps as long as three or four months), normal pumping will usually rid the well of contamination. During this period, a free chlorine residual will make it possible to use the water. Additional information on disinfection is available in AWWA Standard A100.

Sanitary Construction

Wells must be developed from formations sufficiently deep to be protected from surface contamination. The minimum depth of safe water will vary with soil formations and surrounding conditions. In unconsolidated materials, water from depths of 25 ft to 30 ft (8 m to 9 m) or more is reasonably protected. The well casing should extend at least to that depth, and the screen should be set below it.

If a well must be developed at a depth less than that recommended in previous material, an impervious layer of soil at the land surface can provide some protection. A layer of well-compacted clay at least 2 ft (0.6 m) deep should be placed on the land surface for a radius of 50 ft (15 m) around the well. The clay layer will minimize percolation from surface water and tend to divert it to the edge of the clay and away from the well. Every well casing should be grout sealed from land surface to the full depth of the root zone (30 ft to 50 ft), or standing water levels, whichever is less. Many regulatory agencies require a minimum of a 6 ft × 6 ft concrete pad around the well casing, sloped to 1 in./yd.

Another means of protection is to submerge the well screen below the pumping level of water in the well. The water level should not be drawn down into the screen section for long-term operations. Aeration of the well screen promotes aerobic bacteriological activity in deep wells, while cascading water causes air entrainment and possible cavitation of the pump. However, for emergency use, it may be necessary to lower the pump into the screen section. Pump capacities should be selected to ensure from 5 ft to 10 ft (1.5 m to 3 m) of water over the top of the screen at maximum drawdown.

WELL-FIELD DESIGN

As Brown (1953) indicates, the proper design of wells and well fields is possible through measurable field data. The individual water system requirements, area development, geology, hydrology, and climatology must all be considered. The most desirable spacing between wells in a field, the effects of new wells on existing wells, and the optimum pumping rates and schedules can be made once the thickness and extent of an aquifer, its transmissivity and storage coefficient, and the nature and location of boundaries are known. Furthermore, these parameters are very useful when making an overall appraisal of the groundwater resources of an area and the potential for future water supply development. In all cases, these factors should be considered in a logical order as presented in the following paragraphs.

Pumping Rates

When numerical values have been assigned to transmissivity and the storage coefficient, the drawdown effects of pumping can be determined. These effects are for any quantity of water at any reasonable distance from the pumping well. A graphic representation (Figure 5-32) should be plotted of water levels against the logarithm of distance from the center of pumping for a given time period. A minimum continuous pumping period of 100 days is usually used as a conservative safety factor.

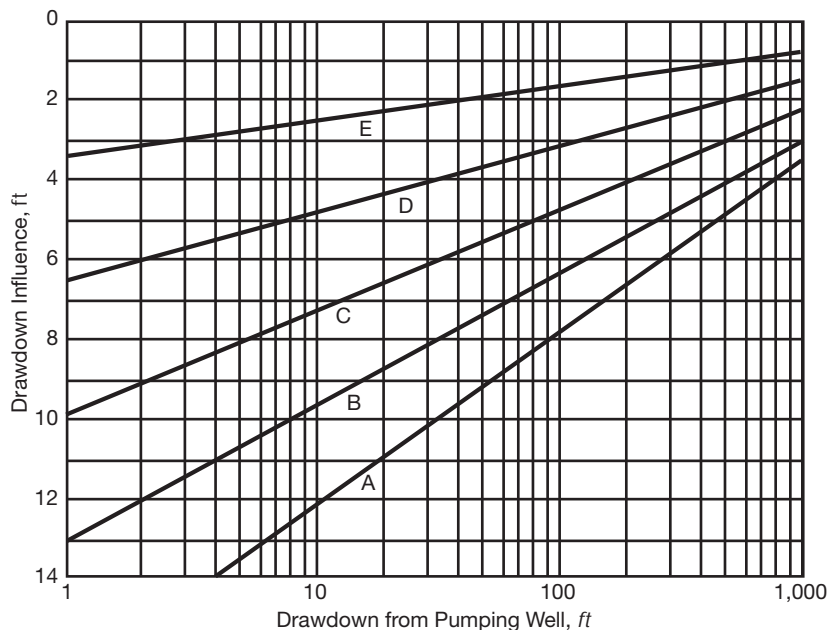

NOTE: Aquifer has a T value of 60,000 gpd/ft and an S value of 0.0055. The Q values (rate of pumping, in gpm) for curve A is 500 gpm, curve B, 400 gpm; curve C, 300 gpm; curve D, 200 gpm; and curve E, 1,000 gpm.

Figure 5-32 Influence for various rates of pumping in an aquifer

To aid in the well design procedure, Nuzman (1989) developed some rule-of-thumb ratios between transmissivity and well specific capacity:

Confined Aquifer $Q/s = T/2,200$ (Eq. 5-6)

Semi-confined aquifer $Q/s = T/1,700$ (Eq. 5-7)

Unconfined aquifer $Q/s = T/1,200$ (Eq. 5-8)

Where

- Q = flow volume
- s = seconds
- T = transmissivity

These ratios were developed for a typical well radius of influence of 1/2 mi, and effective well diameter of 24 in., and assuming a storativity coefficient typical for the aquifer characteristics defined and the general assumptions of a theoretical aquifer (homogenous, isotropic, instant release from storage, infinite areal extent, and no leakage or recharge).

Well-Field Interference

Possible interference between wells in a well field should be determined before locating individual wells or multiple wells in a well field. This step will find the most efficient placement pattern and pumping rates.

As an example, assume that the data given in Figure 5-32 are representative of the hydraulic conditions. The available land for a well field measures 600 ft (182.9 m) on a side. Local health department regulations require a well distance of 200 ft (61 m) from property

Table 5-8 Allowable interference drawdowns for various pumping rates

Pumping Rate <i>gpm</i>	Probable Self Drawdown <i>ft</i>	Allowable Interference Drawdown <i>ft</i>
100	4.4	31.6
200	8.6	27.4
300	12.7	23.3
400	17.2	18.8
500	21.0	15.0

lines and the two most advantageous distributions of wells appear to be either nine wells 100 ft (30.5 m) apart or four wells 200 ft (61 m) apart. From the results of drilling, testing, and calculations, the probable drawdown in the vicinity of a well can be determined for a given pumping rate. The difference between the total available and the calculated drawdown represents the allowable interference drawdown. The total interference drawdowns estimated for various pumping rates are as shown in Table 5-8.

Well-field design is balancing the cost of well and pump installation against the quantity of water produced to get the best returns. An installation with nine wells and pumping rates of 200 gpm (12.6 L/sec) each will serve as an example.

As indicated in Table 5-8, the total interference must not exceed 27.4 ft (8.3 m); in the nine-well pattern, this value is the combined effects of eight other wells. A corner well will be the least affected by the pumping of its companion wells, and the center well will suffer the greatest interference. For the center-well case, the combination of four wells at 100 ft (30.5 m) distance and four wells at 141 ft (43 m) distance will represent the total interference. Referring to the graph in Figure 5-32 and following the 200-gpm line, wells at 100 ft (61 m) will have an influence of 3.1 ft (1 m) per well, and wells at 141 ft (43 m) will have an influence of 2.9 ft (0.9 m) per well. The total interference expected would be $12.4 + 11.6 = 24.0$, which is below the 27.4 ft (8.3 m) maximum allowed over the 100-day pumping period.

Alternatively, a four-well configuration with wells rated at 500 gpm (31.5 L/sec) would require the addition of influences from two wells at 200 ft (61 m) and one well at about 283 ft. The total influence in that case would equal 18.8 ft, which is above the allowable limit. A total of 2,000 gpm (86.3 L/sec) could be produced from this field from a square of eight wells, each pumping 250 gpm (15.8 L/sec), without a center well. The most practical solution, however, would probably be four wells pumping about 425 gpm (26.8 L/sec) each.

Any example can be handled in a similar manner if the transmissivity (T) and submergence (S) values are known and other variables can be reasonably approximated. For very large areas, models and computer calculations may have to be used. A number of field-performance tests for data collection to evaluate T and S for such use increases the reliability of calculated withdrawal effects.

WELL LOSSES

Drawdown values obtained for a single pumping well using the Theis formula (as discussed in chapter 4 and illustrated in Figure 4-17) represent only the head losses suffered by water movement through the formation under laminar flow conditions. The actual pumping level of a particular well cannot be calculated without considering high velocities and turbulence losses during pumping. At and near the well face, fluid velocities usually become so large that turbulent flow conditions exist. The magnitude of turbulence losses varies with each well because of differences in formation characteristics, screen slot

sizes required, degree of well development, well diameter, and quantity of water being pumped. So many unknown quantities are involved in the calculation of these individual factors that they are usually lumped together under the heading of “well losses.”

Calculation

A method of approximating the well losses for a particular well has been presented by Rorabaugh (1953) as follows:

$$s_w = BQ + CQ^2 \quad (\text{Eq. 5-9})$$

Where:

- s_w = observed drawdown in the pumped well
- B = the coefficient of formation losses
- C = the coefficient of well losses
- Q = the pumping rate

The values of B and C may be calculated if proper test data are available. To collect such data, a step-drawdown testing is conducted, during which the finished well must be pumped at three to five increasing rates for equal periods of time and the drawdown measured for each pumping rate and plotted for graphical analysis. A step-drawdown test analysis can differentiate the observed losses in the pumping well. Additionally, this test makes it possible to quickly compare the magnitude of well losses to determine when a well needs cleaning or other repair work. Irregular increasing well loss with increasing pumping rates indicates unsatisfactory development of a new well, or deteriorating aquifer or well conditions in an old well. Small regular increases in well loss or decrease in well specific capacity due to transition to turbulent flow in the aquifer are normal.

A significant factor in well loss for sand and gravel wells is open screen area when the percentage of open area is substantially less than the specific yield of the aquifer. Research by D.E. Williams (1985) has shown that when the open area of the screen is greater than the specific capacity of the formation, the actual head loss across the well screen is insignificant until the velocity through the screen exceeds 2 ft/sec (0.6 m/sec). In an attempt to limit turbulent flow losses around the well bore hole, many regulatory agencies have prescribed velocities from screen openings between 0.1 ft/s and 0.2 ft/s (0.03 m/s and 0.06 m/s) and a minimum thickness of gravel pack resulting in large-diameter well construction. High-velocity turbulent flow through the formation borehole results in higher pumping, clogging, and higher maintenance costs. In this case, velocity is a function of quantity and area and is easily approximated in the design stages.

Because the quantity of water to be pumped from a well Q is more correctly established using formation loss and well interference, the open area of screen is the basic parameter to consider. Screen slot size should be selected for accurate sampling and proper sieve analysis. Thus, the screen diameter and length are the two variables in design.

In choosing a supply-well diameter, the pumping equipment that will be installed in the final well needs to be selected. An 8-in. (200-mm) turbine pump should not be installed in an 8-in. (200-mm) diameter well, for example. The minimum casing and screen diameter should be at least one pipe size larger than the largest diameter of the pumping equipment to be installed. This gap allows adequate space for pump installation and removal, efficient pump operation, and good hydraulic efficiency of the well.

Screen-length selection should incorporate more than a casual recollection of the aquifer thickness. The definition of transmissivity T incorporates flow through the total thickness of water-bearing material. If less than the total thickness is used, the value of T should be decreased. The Theis equation indicates that as T decreases, the formation

drawdown will increase, although not directly proportional. If the screened portion of the formation is significantly less than one half of the formation thickness, the additional drawdown suffered may be significant; therefore, as much of the aquifer as practical should be screened to eliminate losses of yield.

RADIAL-WELL YIELD

A detailed description of a radial well is given in this chapter. Yields of these types of wells depend on a permeable aquifer, a high water table, and an adequate, nearby source of water of acceptable quality. A radial well must be designed to allow the desired volume of water to enter the gallery and prevent fine-grained material from entering the well. Entrance velocities through the screen slot openings should average about 0.1 ft/s (0.03 m/s) or less. Capacities of collectors can vary considerably, depending on aquifer characteristics and well design. Yields may range upward to several hundred gallons per minute (700 to 800 L per minute) per 1,000 ft (300 m) of gallery length.

MODELING TECHNIQUES

A groundwater model represents a field situation. Groundwater modeling efforts predict hydraulic conditions in space and time. Models are valuable tools for addressing groundwater flow, contaminant migration, groundwater resources management, and the behavior of groundwater systems under stress. Three types of groundwater models are physical-scale, analog, and mathematical (analytical, analytical-element, semi-analytical, or numerical) models. This section focuses on the requirements, steps for application, limitations, and uses of the mathematical model. Mathematical models are far more versatile, less costly, and certainly less space-intensive to use than analog models.

A mathematical model is a somewhat simplified representation of a complex hydrogeological system. A *hydrogeological system* is defined as a set of physical, chemical, or biological processes acting on input variables to convert them into output variables. A *variable* is a characteristic of a system that can be measured, and which may have different values when measured at different times. Validity of the prediction depends on how well the model approximates actual field conditions.

Simple analytical models apply the groundwater flow equation across the model domain. Numerical models begin with a basic equation of groundwater flow solved for the hydraulic head distribution in the aquifer, but break the solution up into elements to better mimic the complexity of a hydrogeologic system. Most of the numerical groundwater models currently used are based on the USGS finite-difference groundwater model MODFLOW, although finite-element methods that offer more flexibility in grid design are used. Gridded (finite-difference or finite-element) methods mimic 3-dimensional systems by incorporating layers of grids.

Solute-transport models add an equation for the changes in chemical concentration in the groundwater. These are based on MODFLOW results as well. Aquifer deformation models combine the flow equation with other equations that describe the changes in the physical structure of the aquifer with changes in the hydraulic head. Land subsidence due to groundwater withdrawal has been studied with the use of deformation models.

Accurate and adequate field data are essential when using modeling for predictive purposes. However, a model with inadequate data can be instructive, as it may identify those areas where detailed field data are critical to the success of the model. A mathematical model can manipulate a complex set of equations to provide a useful result at less expense than manual methods.

Computer models are most widely used at regional levels for management decisions. The groundwater issues are of a scale that makes computer modeling economically viable. Most regional groundwater modeling helps planners determine the groundwater flow system and the parameters affecting feasibility, investment, and operations decisions related to particular site-specific problems.

However, numerical models such as MODFLOW are commonly used for well-field-scale planning and associated tasks such as source water protection area delineation. A MODFLOW grid may also be used to model complex well flow systems and other small-scale tasks.

Objectives of Modeling

Some of the objectives of modeling are to

- predict the effect of pumping on groundwater levels
- predict the effect of installing additional pumping wells
- determine the effects of natural/artificial recharge
- determine the effects of recharge and barrier boundaries
- determine the effect of lithologic and stratigraphic variations (the transmissivity in x and y directions)
- predict the variation of concentration of contaminants from source to observation point
- determine the effects of retarding factors of contamination concentration (dilution, dispersion, adsorption, time-decay)
- predict the effects of remediation at different locations, both horizontally and vertically

Steps in Modeling

Before groundwater modeling is undertaken, it is important to define the problem to be modeled, the scope of the project, the acceptable level of confidence, and the scale of model.

Steps in groundwater modeling include (Figure 5-33)

- defining the problem to be addressed
- collecting and processing data on water flow, topographic information, aquifer characteristics, and leakance.
- designing a conceptual model (the physical setting)
- formulating a model
- selecting the computer model to be used for the simulation
- specifying the structure of the model, including its geometric features, dimensions and internal parameters, boundary conditions, and the initial conditions
- testing the sensitivity of the model
- calibrating and verifying the model with field conditions
- designing and executing simulations
- analyzing simulation data (including calibration)
- presenting results

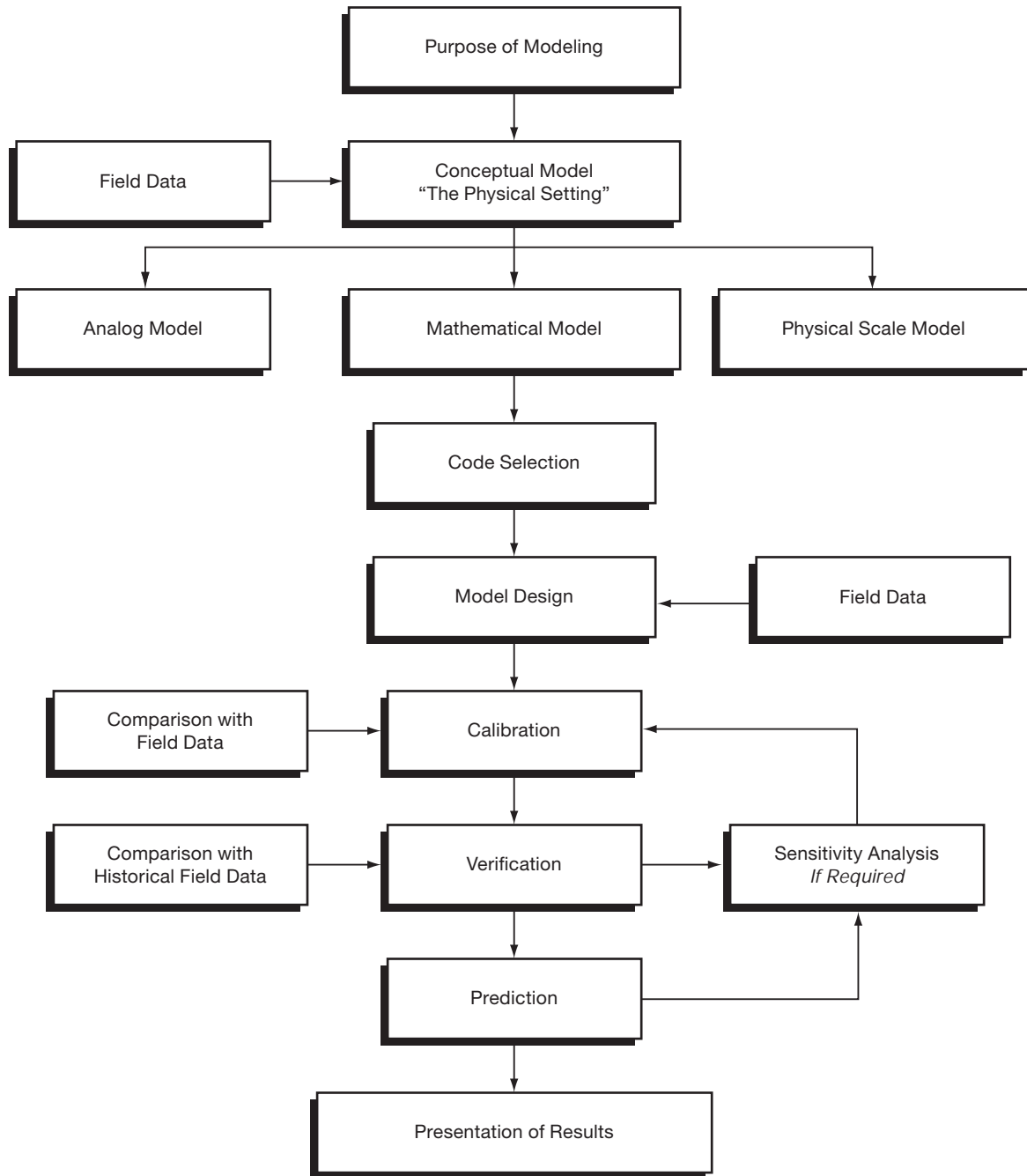

Figure 5-33 Steps for model application

Conceptual Models: Prerequisite Data

To convert a conceptual model into a mathematical model, a database of accurate information must be developed. The configuration of the aquifer to be modeled is required, including the following:

- the location
- areal extent of the aquifer to be modeled

- the thickness of the aquifer and confining units
- the locations of surface-water bodies and streams
- structural features in rock-aquifer systems such as linear faults or grabens
- the boundary conditions of all aquifers

Required hydraulic properties include the following:

- the variation of transmissivity or hydraulic conductivity and storage coefficient of the aquifer and confining units
- the variation of hydraulic conductivity and specific storage of the confining layers
- the hydraulic connection between the aquifers and surface-water bodies
- hydraulic properties of fracture zones or fill zones in rock bodies
- hydraulic head, as indicated by water-table or potentiometric-surface maps
- amounts of recharge to the aquifer by precipitation and natural stream flow

To simulate stresses on a natural groundwater flow system, the locations, types, and amounts of any artificial recharge through time, such as impacts from recharge basins and wells or return flow from irrigation must be known. Also, the amounts and locations, through time, of groundwater withdrawals from wells need to be calculated. Changes in the amount of water flowing in streams and changes in the water levels of surface-water bodies should also be known.

The flow model is used to compute the direction and the rate of fluid movement. The solute-transport equations are used to determine movement of contaminants. The information required for solute-transport models includes

- the distribution of effective porosity
- aquifer dispersivity factors
- fluid-density variations
- concentrations of solute(s) distributed throughout the aquifer
- the locations and concentrations of the contaminants
- the retardation factors for the specific solutes with the specific rocks and soils of the area

Model Calibration

When a model is calibrated, it will produce field-measured hydraulic heads at nodal points in the grid for a given combination of parameters and boundary conditions. Calibration requires adjusting the input data until computed values match the field values. Input data are hydraulic conductivity, transmissivity, storage coefficient, and recharge.

A mathematical model is calibrated by taking the initial estimates of the aquifer parameters, solving the equations, and comparing the results to known conditions of the aquifer under steady-state groundwater head. A water-table or potentiometric-surface map is used for calibration. Water-level data are recognized as more accurate than the distribution of aquifer parameters and/or amount of recharge. The values for the aquifer parameters and recharge are varied until the model closely reproduces the known water-table or potentiometric-surface condition. The calibration process can take as many as 50 or more trial-and-error simulations before a desired level of calibration is achieved.

The ability of a calibrated model to duplicate current groundwater system behavior does not necessarily verify its ability to predict future cause and effect relations. A calibrated model must be verified for any historical changes (transient conditions) before it can be used to predict.

Model Verification

A mathematical model must be capable of simulating historical hydrologic events for which field data are available. A model is verified by comparing results to historical records. A transient response of the model is obtained and compared with a known transient condition in the aquifer. If the water levels through time and the locations and withdrawal rates from wells are known, the model should reproduce the known water-level changes. If the historical records are not reproduced to a desired degree of accuracy, the model parameters can be adjusted and the verification repeated. This process should eventually result in a verified model. Once the model has been verified against a transient event, it should be checked against the steady-state condition to ensure that it is still calibrated. Unfortunately, most mathematical models are not field verified, as this is time-consuming and expensive.

Limitations

While analytical modeling groundwater flow and transport of a single nonreactive contaminant in saturated porous media is a relatively simple process, it measures the mean of the average conditions. It is far more difficult to replicate exact conditions because the model parameters are by nature, averages over large areas. This makes calibration more difficult. Modeling becomes more complicated in aquifers of partial saturation, where there is fracturing or the existence of reactive contaminants, or if several mobile fluids are involved. Expert application of gridded numerical models allows much closer approximation to “real” conditions, especially with software that permits refinement of grid size and in some cases, shape.

Groundwater flow in fractured media is complex and can be difficult to predict at a given site unless extensive information is available about the fracture network. Recent research has made some advancement in the understanding of fracture and matrix flow in fractured media. Over-simplification, such as assuming that the effects of individual fractures will “average out,” can produce errors, particularly when models are used in predicting the flow and movement of contaminants. However, long experience with extensively fractured aquifer media such as older North American mid-continent rock aquifers shows that they behave as quasi-porous media at the regional scale. At the well-field scale, defining structural influences (and certainly karstic features) is essential.

Modeling contaminant transport depends on the compound and its phase. Transportation of dilute, nonreactive aqueous phase solutes is well understood, with the exception of the effects of temporal and spatial variability within the aquifer. Studies indicate that real-world contaminant plumes have complex and difficult-to-predict three-dimensional structures in soils that are heterogeneous. Modeling reactive solutes is more complex because chemical rather than hydrologic process may govern the behavior and movement of plume.

It is easy, with modern software packages, to underestimate the task of aquifer modeling. This work should be conducted by qualified hydrologic modelers. Without a modeler’s adequate understanding of the hydrogeologic setting, the groundwater system, chemical characteristics, and movement of contaminants, modeling results will provide uncertain predictions. Uncertainty in modeling includes

- numerical errors
- inability to precisely describe the natural variability of model parameters (e.g., hydraulic conductivity) from a finite and usually small number of measurement points
- inherent complexity of geologic and hydrogeologic processes over the long term

- inability to measure or otherwise quantify certain critical parameters (e.g., features of the geometry of fracture networks)
- conceptual deficiencies
- biases or measurement errors that are part of common field methods
- establishing values of controlling parameters such as velocity, effective porosity, diffusion coefficient, and dispersivity, which are difficult to measure or estimate because these features vary spatially

Because of these uncertainties, any single source of information should not be relied on when formulating regulations, evaluating water resources, cleaning up an aquifer, or protecting public health. The model provides results based on the conditions entered. Regulatory and groundwater protection have higher risks during more extreme conditions. Careful field work and confirmation of conditions are required to perform a quantitative and defensible assessment of the model's accuracy.

Applications

Properly applied models are useful tools to

- assist in problem evaluation
- conceptualize and study flow processes
- recognize limitations in data and guide collection of new data
- design remedial strategies
- provide additional information for decision making

Groundwater models are valuable tools that can be used to help understand the movement of water and chemicals in the subsurface. The results of model application are dependent on the quality of the data used as input for the model. Generally, site-specific data are required to develop a reliable model of a site. There are inherent inaccuracies and simplifying assumptions in the theoretical equations, the boundary and other conditions, and in the computer codes. Therefore, the results must be evaluated with other information about site conditions to make decisions about groundwater development and cleanup.

Federal and state or provincial and other regional agencies have guidelines that encourage the proper use of mathematical models. Some government regulations require modeling for long-term predictions of water resources and potential chemical migration. Models used in regulatory or legal proceedings should be available for evaluation to determine the application of the model to a particular site and quality of the model. Issues such as the extent to which equations describe the actual processes and the steps taken to verify that the code correctly solves the governing equations and is fully operational (i.e., code verification) should be considered.

Lists of published models are available that can be selected for a particular application and site. Government officials may be reluctant to accept a model that has not been approved previously by the agency. Getting governmental approval of an alternate model may be a lengthy process.

Published Mathematical Models

Many mathematical models have been developed, debugged, and applied to field situations. An existing appropriate model is more cost-effective than developing new models. Groundwater models do, and should, vary in complexity because of the variation in hydrogeology. While more complex models increase the range of situations that can be described, increasing complexity requires more input data, requires a higher level and

range of skill of the modelers, and may introduce greater uncertainty in the output if input data are not available or of sufficient quality.

For more information on published models in the public domain and readily available, go to www.usgs.gov or www.epa.gov.

REFERENCES

- Australian Drilling Industry Training Committee. 1997. *Drilling: The Manual of Methods, Applications, and Management*. Boca Raton, Fla.: CRC Press/Lewis Publishers.
- Bloetscher, F., A. Muniz, and J. Largey. 2007. *Siting, Drilling, and Construction of Water Supply Wells*. Denver, Colo.: American Water Works Association.
- Brown, R.H. 1953. Selected Procedures for Analyzing Aquifer Test Data. *Jour. AWWA*. 4518–2844.
- Driscoll F.G. 1986. *Groundwater and Wells*. St. Paul, Minn.: Johnson Division.
- National Ground Water Assn. 1998. *Manual of Water Well Construction Processes*. Westerville, Ohio: National Ground Water Association.
- Nuzman, C.E. 1989. Well Hydraulic Flow Concept. In: *Recent Advances in Groundwater Hydrology*. Minneapolis, Minn.: American Institute of Hydrology.
- Rorabaugh, M.I. 1953. Graphical and Theoretical Analysis of the Step Drawdown Test of Artesian Wells. *ASCB*. No. 362, 79.
- Roscoe Moss Co. 1990. *Handbook of Groundwater Development*. New York, N.Y.: Wiley InterScience.
- Williams, D.E. 1985. Modern Techniques in Well Design. *Jour. AWWA* 77(9).
- Williams, E.B. 1981. Fundamental Concepts of Well Design. *Ground Water* 19(3): 527–542.

This page intentionally blank.

Well Pumps and Pumping

Pumps produce flow by transforming mechanical energy to hydraulic energy. Pump designs and applications are numerous, and energy specifications and ratings for pumps range from less than one to thousands of horsepower per pump. To understand pumps and how they work, understanding the basic terminology is helpful.

Capacity is the rate of flow delivered by a pump, in units such as gallons per minute, cubic feet per second, or barrels per hour. To calculate the power needed or the size of prime mover required to produce a desired capacity, the rate of flow and total dynamic head must be determined (Hicks and Edwards 1971; Jones 2006).

Dynamic head is resistance to flow produced by a system, equal to the sum of static head, velocity head, and friction head (Jones 2006).

- *Static head* is the sum of the static suction head and the static discharge head (Figure 6-1; Jones 2006). To calculate static head, all measurements in pumping are vertical and the maximum drawdown is used as a reference. Measurements above this level are positive; those below, negative. The same measuring procedure can be used for both submersible and surface-mounted pumps.
 - *Static suction head* is the vertical measurement, in feet, of the distance from the water level in a well to the pump centerline.
 - *Static discharge head* is the distance measured vertically from the pump centerline to the water level in storage.
 - *Velocity head* is the height through which a buoy must fall freely to attain its velocity. In most cases, the velocity head is small and can be ignored. Table 6-1 provides a way to determine velocity head.
 - *Friction head* is the loss of energy due to fluid motion along the inner surfaces of pipe and through fittings (Dougherty and Franzini 1977). With no change in

elevation, friction head is the amount of head necessary to push fluid through pipe and fittings at the required velocity. Table 6-2 can be used to determine friction head when various steel pipe sizes and different flow rates are used. Friction head loss through fittings must be included (Table 6-3). Head losses for fittings are expressed in equivalent feet of pipe (Dougherty and Franzini 1977). For example, the loss through a regular 4-in. 90° elbow is equivalent to the loss through 13 ft of 4-in. pipe at the measured flow rate.

To accurately calculate head loss, pressure expressed in pounds per square inch (psi) must be converted to pressure expressed in feet of head

$$\text{head, in feet} = \text{psi} \times \frac{144}{w} \tag{Eq. 6-1}$$

Where:

w = specific weight, in pounds per cubic foot

The specific weight of water at temperatures less than 85° F is 8.34 lb/gal or 62.4 lb/ft³; each foot of water causes a change in pressure of 0.433 psi. To change from feet of water to pounds per square inch, multiply by 0.433 or divide by 2.307. For example, the pressure in pounds per square inch at the bottom of a storage tank containing a 10-ft depth of water is

$$\begin{aligned} \text{pressure, in psi} &= 10 \times 0.433, \text{ or} \\ &= 10 \div 2.307 \\ &= 4.33 \text{ psi} \end{aligned}$$

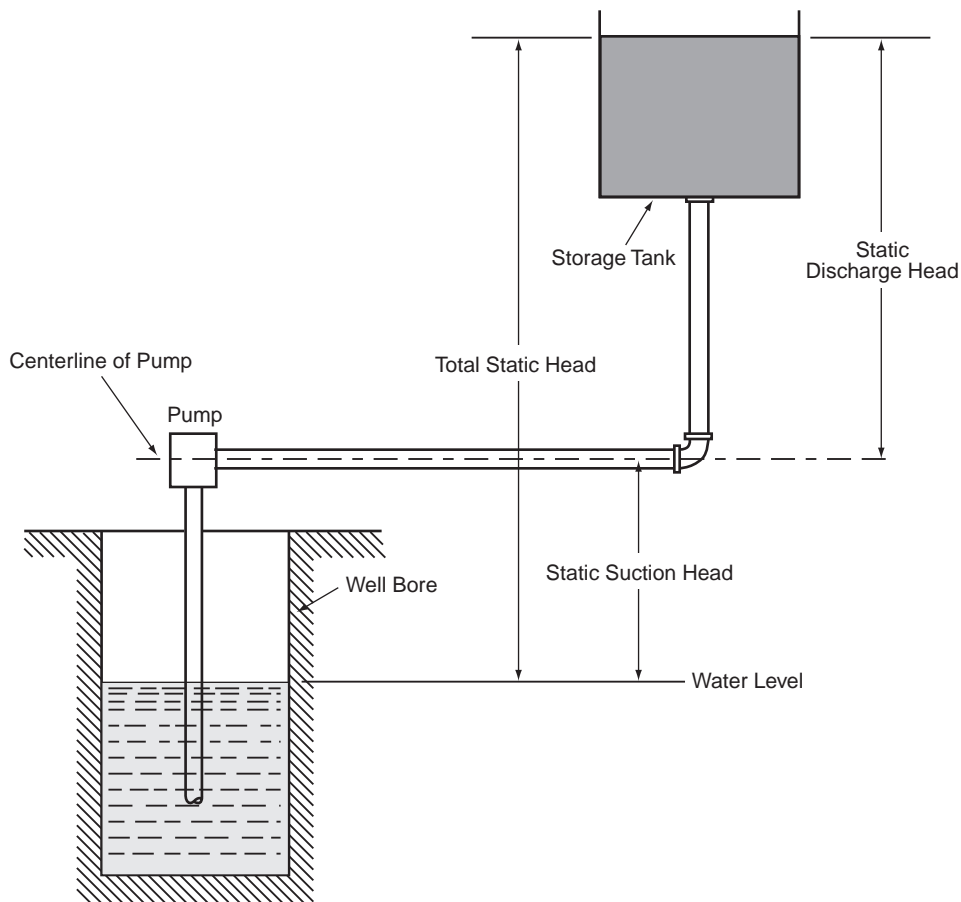

Figure 6-1 Schematic illustrating total static head

Table 6-1 Velocity-head data

Velocity (<i>V</i>) <i>fps</i>	Velocity Head (<i>h_v</i>)* <i>ft</i>	Velocity (<i>V</i>) <i>fps</i>	Velocity Head (<i>h_v</i>)* <i>ft</i>
1	0.02	11	1.87
2	0.06	12	2.24
3	0.14	13	2.62
4	0.25	14	3.04
5	0.36	15	3.49
6	0.56	16	3.97
7	0.76	17	4.44
8	1.00	18	5.03
9	1.25	19	5.61
10	1.55	20	6.21

* $h_v = V^2/2g$; g = acceleration due to gravity.

The net positive suction head (NPSH) is the amount of pressure that prevents water from vaporizing. The NPSH can cause cavitation (the formation and collapse of water vapor bubbles in the flowing water) and damage a pump. The required or minimum NPSH usually is stated by the pump manufacturer. The available NPSH is approximately equal to the distance from the eye of the pump impeller to the water level in the well while pumping. The available NPSH must be at least equal to the required NPSH to prevent cavitation. If necessary, the required NPSH can be satisfied by lowering the pump in the well.

PUMP CLASSIFICATIONS

Several types of pumps are used today. Only those pumps generally used to pump water from wells are described in the following sections. Table 6-5 at the end of this section (p. 152) provides a summary of the types of pumps discussed in this chapter.

Centrifugal Pump

The most important and most common pump for transmitting water from wells is the centrifugal pump (Driscoll 1986). A centrifugal pump uses centrifugal force to move a liquid through a change in elevation or against a total dynamic head. The pump consists of a suction nozzle, an impeller eye, an impeller (rotating element), a volute, and a discharge nozzle. As fluid is drawn through the suction nozzle to the impeller eye, rotation of the impeller gives the fluid a high-velocity radial motion. Centrifugal force throws fluid from the outer tips of the impeller into the volute or diffuser and into the discharge line.

In both volute and diffuser types of centrifugal pumps, velocity head and, consequently, pressure are developed entirely by centrifugal force. In the volute-type pump (Figure 6-2), the impeller discharges fluid into a gradually expanding case (Stewart 1977). The volute efficiently changes part of the velocity head of the fluid leaving the impeller to pressure head (Stewart 1977). In the diffuser-type pump (Figure 6-3), the impeller is surrounded by progressively expanding passages of stationary guide vanes. The diffuser pump does a more complete job of converting velocity head to pressure (Hicks and Edwards 1971), and consequently, is more efficient than the volute type.

Table 6-2 Friction loss for water in ft per 100 ft (Schedule 40 Steel Pipe)

Flow <i>gpm</i>	2 in.		2 ½ in.		3 in.		4 in.	
	<i>V</i> <i>ft/s</i>	<i>h_f</i> Friction	<i>V</i> <i>ft/s</i>	<i>h_f</i> Friction	<i>V</i> <i>ft/s</i>	<i>h_f</i> Friction	<i>V</i> <i>ft/s</i>	<i>h_f</i> Friction
25	2.39	1.29						
30	2.87	1.82						
35	3.35	2.42	2.35	1.00				
40	3.82	3.10	2.68	1.28				
45	4.30	3.85	3.02	1.60				
50	4.78	4.67	3.35	1.94	2.17	0.662		
60	5.74	6.59	4.02	2.72	2.60	0.924		
70	6.69	8.86	4.69	3.63	3.04	1.22		
80	7.65	11.4	5.36	4.66	3.47	1.57		
90	8.60	14.2	6.03	5.82	3.91	1.96		
100	9.56	17.4	6.70	7.11	4.34	2.39	2.52	0.624
120	11.5	24.7	8.04	10.0	5.21	3.37	3.02	0.877
140	13.4	33.2	9.38	13.5	6.08	4.51	3.53	1.17
160	15.3	43.0	10.7	17.4	6.94	5.81	4.03	1.49
180			12.1	21.9	7.81	7.28	4.54	1.86
200			13.4	26.7	8.68	8.90	5.04	2.27
220			14.7	32.2	9.55	10.7	5.54	2.72
240			16.1	38.1	10.4	12.6	6.05	3.21
260					11.3	14.7	6.55	3.74
280					12.2	16.9	7.06	4.30
300					13.0	19.2	7.56	4.89
350					15.2	26.1	8.82	6.55
400							10.10	8.47
450							11.4	10.65
500							12.6	13.0
550							13.9	15.7
600							15.1	18.6

NOTE: The table shows average values of pipe friction for new pipe. For commercial installations it is recommended that 15 percent be added to these values because no allowance for aging of pipe is included.

NOTE: Tables shown for Schedule 40 steel pipe are provided for example purposes only. For friction loss tables for other materials, consult the manufacturer.

Table continues on next page.

Table 6-2 Friction loss for water in ft per 100 ft (Schedule 40 Steel Pipe) (continued)

Flow <i>gpm</i>	5 in.		6 in.		8 in.	
	<i>V</i> <i>ft/s</i>	<i>h_f</i> Friction	<i>V</i> <i>ft/s</i>	<i>h_f</i> Friction	<i>V</i> <i>ft/s</i>	<i>h_f</i> Friction
160	2.57	0.487				
180	2.89	0.606				
200	3.21	0.736				
220	3.53	0.879	2.44	0.357		
240	3.85	1.035	2.66	0.419		
260	4.17	1.20	2.89	0.487		
300	4.81	1.58	3.33	0.637		
350	5.61	2.11	3.89	0.851		
400	6.41	2.72	4.44	1.09	2.57	0.279
450	7.22	3.41	5.00	1.36	2.89	0.348
500	8.02	4.16	5.55	1.66	3.21	0.424
600	9.62	5.88	6.66	2.34	3.85	0.597
700	11.2	7.93	7.77	3.13	4.49	0.797
800	12.8	10.22	8.88	4.03	5.13	1.02
900	14.4	12.9	9.99	5.05	5.77	1.27
1,000	16.0	15.8	11.1	6.17	6.41	1.56
1,100			12.2	7.41	7.05	1.87
1,200			13.3	8.76	7.70	2.20
1,300			14.4	10.2	8.34	2.56
1,400			15.5	11.8	8.98	2.95
1,500					9.62	3.37
1,600					10.3	3.82
1,700					10.9	4.29
1,800					11.5	4.79
1,900					12.2	5.31
2,000					12.8	5.86
2,100					13.5	6.43
2,200					14.1	7.02

NOTE: The table shows average values of pipe friction for new pipe. For commercial installations, it is recommended that 15 percent be added to these values because no allowance for aging of pipe is included.

Table continues on next page.

Table 6-2 Friction loss for water in ft per 100 ft (Schedule 40 Steel Pipe) (continued)

Flow <i>gpm</i>	10 in.		12 in.		14 in.	
	<i>V</i> <i>ft/s</i>	<i>h_f</i> Friction	<i>V</i> <i>ft/s</i>	<i>h_f</i> Friction	<i>V</i> <i>ft/s</i>	<i>h_f</i> Friction
650	2.64	0.224				
700	2.85	0.256				
750	3.05	0.294				
800	3.25	0.328				
850	3.46	0.368				
900	3.66	0.410	2.58	0.173		
950	3.87	0.455	2.72	0.191		
1,000	4.07	0.500	2.87	0.210	2.37	0.131
1,100	4.48	0.600	3.15	0.251	2.61	0.157
1,200	4.88	0.703	3.44	0.296	2.85	0.185
1,300	5.29	0.818	3.73	0.344	3.08	0.215
1,400	5.70	0.940	4.01	0.395	3.32	0.217
1,500	6.10	1.07	4.30	0.450	3.56	0.281
1,600	6.51	1.21	4.59	0.509	3.79	0.317
1,700	6.92	1.36	4.87	0.572	4.03	0.355
1,800	7.32	1.52	5.16	0.636	4.27	0.395
1,900	7.73	1.68	5.45	0.704	4.50	0.438
2,000	8.14	1.86	5.73	0.776	4.74	0.483
2,500	10.2	2.86	7.17	1.187	5.93	0.738
3,000	12.2	4.06	8.60	1.68	7.11	1.04
3,500	14.2	5.46	10.0	2.25	8.30	1.40
4,000	16.3	7.07	11.5	2.92	9.48	1.81
4,500			12.9	3.65	10.7	2.27
5,000			14.3	4.47	11.9	2.78
6,000			17.2	6.39	14.2	3.95
7,000					16.6	5.32
8,000						

NOTE: The table shows average values of pipe friction for new pipe. For commercial installations, it is recommended that 15 percent be added to these values because no allowance for aging of pipe is included.

Table continues on next page.

Table 6-2 Friction loss for water in ft per 100 ft (Schedule 40 Steel Pipe) (continued)

Flow <i>gpm</i>	16 in.		18 in.		20 in.		24 in.	
	<i>V</i> <i>ft/s</i>	<i>h_f</i> Friction	<i>V</i> <i>ft/s</i>	<i>h_f</i> Friction	<i>V</i> <i>ft/s</i>	<i>h_f</i> Friction	<i>V</i> <i>ft/s</i>	<i>h_f</i> Friction
1,400	2.54	0.127						
1,600	2.90	0.163						
1,700	3.09	0.183						
1,800	3.27	0.203	2.58	0.114				
1,900	3.45	0.225	2.73	0.126				
2,000	3.63	0.248	2.87	0.139	2.31	0.0812		
2,500	4.51	0.377	3.59	0.211	2.89	0.123		
3,000	5.45	0.535	4.30	0.297	3.46	0.174	2.39	0.070
3,500	6.35	0.718	5.02	0.397	4.04	0.232	2.79	0.093
4,000	7.26	0.921	5.74	0.511	4.62	0.298	3.19	0.120
4,500	8.17	1.15	6.45	0.639	5.19	0.372	3.59	0.149
5,000	9.08	1.41	7.17	0.781	5.77	0.455	3.99	0.181
6,000	10.9	2.01	8.61	1.11	6.92	0.645	4.79	0.257
7,000	12.7	2.69	10.0	1.49	8.08	0.862	5.59	0.343
8,000	14.5	3.49	11.5	1.93	9.23	1.14	6.38	0.441
9,000	16.3	4.38	12.9	2.42	10.39	1.39	7.18	0.551
10,000			14.3	2.97	11.5	1.70	7.98	0.671
11,000			15.8	3.57	12.7	2.05	8.78	0.810
12,000					13.8	2.44	9.58	0.959
13,000					15.0	2.86	10.4	1.42
14,000					16.2	3.29	11.2	1.29
15,000							12	1.48
16,000							12	1.67
17,000							13.6	1.88
18,000							14.4	2.10
19,000							15.2	2.33

NOTE: The table shows average values of pipe friction for new pipe. For commercial installations, it is recommended that 15 percent be added to these values because no allowance for aging of pipe is included.

Table 6-3 Equivalent length of new straight pipe for valves and fittings for turbulent flow only

Fittings	Pipe size, <i>in.</i>																							
	1/4	3/8	1/2	3/4	1	1 1/4	1 1/2	2	2 1/2	3	4	5	6	8	10	12	14	16	18	20	24			
Regular 90° Ell	Steel	2.3	3.1	3.6	4.4	5.2	6.6	7.4	8.5	9.3	11	13	—	—	—	—	—	—	—	—	—	—		
	C.I.	—	—	—	—	—	—	—	—	—	9.0	11	—	—	—	—	—	—	—	—	—	—		
Flanged	Steel	—	—	.92	1.2	1.6	2.1	2.4	3.1	3.6	4.4	5.9	7.3	8.9	12	14	17	18	21	23	25	30		
	C.I.	—	—	—	—	—	—	—	—	—	3.6	4.8	—	7.2	9.8	12	15	17	19	22	24	28		
Long Radius 90° Ell	Steel	1.5	2.0	2.2	2.3	2.7	3.2	3.4	3.6	3.6	4.0	4.6	—	—	—	—	—	—	—	—	—	—		
	C.I.	—	—	—	—	—	—	—	—	—	3.3	3.7	—	—	—	—	—	—	—	—	—	—		
Flanged	Steel	—	—	1.1	1.3	1.6	2.0	2.3	2.7	2.9	3.4	4.2	5.0	5.7	7.0	8.0	9.0	9.4	10	11	12	14		
	C.I.	—	—	—	—	—	—	—	—	—	2.8	3.4	—	4.7	5.7	6.8	7.8	8.6	9.6	11	11	13		
Regular 45° Ell	Steel	.34	.52	.71	.92	1.3	1.7	2.1	2.7	3.2	4.0	5.5	—	—	—	—	—	—	—	—	—	—		
	C.I.	—	—	—	—	—	—	—	—	—	3.3	4.5	—	—	—	—	—	—	—	—	—	—		
Flanged	Steel	—	—	.45	.59	.81	1.1	1.3	1.7	2.0	2.6	3.5	4.5	5.6	7.7	9.0	11	13	15	16	18	22		
	C.I.	—	—	—	—	—	—	—	—	—	2.1	2.9	—	4.5	6.3	8.1	9.7	12	13	15	17	20		
Tee-Line Flow	Steel	.79	1.2	1.7	2.4	3.2	4.6	5.6	7.7	9.3	12	17	—	—	—	—	—	—	—	—	—	—		
	C.I.	—	—	—	—	—	—	—	—	—	9.9	14	—	—	—	—	—	—	—	—	—	—		
Flanged	Steel	—	—	.69	.82	1.0	1.3	1.5	1.8	1.9	2.2	2.8	3.3	3.8	4.7	5.2	6.0	6.4	7.2	7.6	8.2	9.6		
	C.I.	—	—	—	—	—	—	—	—	—	1.9	2.2	—	3.1	3.9	4.6	5.2	5.9	6.5	7.2	7.7	8.8		
Tee-Branch Flow	Steel	2.4	3.5	4.2	5.3	6.6	8.7	9.9	12	13	17	21	—	—	—	—	—	—	—	—	—	—		
	C.I.	—	—	—	—	—	—	—	—	—	14	17	—	—	—	—	—	—	—	—	—	—		
Flanged	Steel	—	—	2.0	2.6	3.3	4.4	5.2	6.6	7.5	9.4	12	15	18	24	30	34	37	43	47	52	62		
	C.I.	—	—	—	—	—	—	—	—	—	7.7	10	—	15	20	25	30	35	39	44	49	57		
180° Return Bend	Steel	2.3	3.1	3.6	4.4	5.2	6.6	7.4	8.5	9.3	11	13	—	—	—	—	—	—	—	—	—	—		
	C.I.	—	—	—	—	—	—	—	—	—	9.0	11	—	—	—	—	—	—	—	—	—	—		
Reg. Flanged	Steel	—	—	.92	1.2	1.6	2.1	2.4	3.1	3.6	4.4	5.9	7.3	8.9	12	14	17	18	21	23	25	30		
	C.I.	—	—	—	—	—	—	—	—	—	3.6	4.8	—	7.2	9.8	12	15	17	19	22	24	28		
Long Rad. Flanged	Steel	—	—	1.1	1.3	1.6	2.0	2.3	2.7	2.9	3.4	4.2	5.0	5.7	7.0	8.0	9.0	9.4	10	11	12	14		
	C.I.	—	—	—	—	—	—	—	—	—	2.8	3.4	—	4.7	5.7	6.8	7.8	8.6	9.6	11	11	13		
Globe Valve	Steel	21	22	22	24	29	37	42	54	62	79	110	—	—	—	—	—	—	—	—	—	—		
	C.I.	—	—	—	—	—	—	—	—	—	65	86	—	—	—	—	—	—	—	—	—	—		
Flanged	Steel	—	—	38	40	45	54	59	70	77	94	120	150	190	260	310	390	—	—	—	—	—		
	C.I.	—	—	—	—	—	—	—	—	—	77	99	—	150	210	270	330	—	—	—	—	—		

Table continues on next page.

Table 6-3 Equivalent length of new straight pipe for valves and fittings for turbulent flow only (continued)

		Pipe size, in.																				
		1/4	3/8	1/2	3/4	1	1 1/4	1 1/2	2	2 1/2	3	4	5	6	8	10	12	14	16	18	20	24
Gate Valve	Fittings																					
	Screwed	Steel .32	.45	.56	.67	.84	1.1	1.2	1.5	1.7	1.9	2.5	—	—	—	—	—	—	—	—	—	—
Flanged	C.I.	—	—	—	—	—	—	—	—	—	1.6	2.0	—	—	—	—	—	—	—	—	—	—
	Steel	—	—	—	—	—	—	2.6	2.7	2.8	2.9	3.1	3.2	3.2	3.2	3.2	3.2	3.2	3.2	3.2	3.2	3.2
Angle Valve	C.I.	—	—	—	—	—	—	—	—	—	2.3	2.4	—	2.6	2.7	2.8	2.9	2.9	3.0	3.0	3.0	3.0
	Steel	12.8	15	15	15	17	18	18	18	18	18	18	—	—	—	—	—	—	—	—	—	—
Flanged	C.I.	—	—	—	—	—	—	—	—	—	15	15	—	—	—	—	—	—	—	—	—	—
	Steel	—	—	15	15	17	18	18	21	22	28	38	50	63	90	120	140	160	190	210	240	300
Swing Check Valve	C.I.	—	—	—	—	—	—	—	—	—	23	31	—	52	74	98	120	150	170	200	230	280
	Steel	7.2	7.3	8.0	8.8	11	13	15	19	22	27	38	—	—	—	—	—	—	—	—	—	—
Coupling or Union	C.I.	—	—	—	—	—	—	—	—	—	22	31	—	—	—	—	—	—	—	—	—	—
	Steel	—	—	3.8	5.3	7.2	10	12	17	21	27	38	50	63	90	120	140	—	—	—	—	—
Screwed	C.I.	—	—	—	—	—	—	—	—	—	22	31	—	52	74	98	120	—	—	—	—	—
	Steel	.14	.18	.21	.24	.29	.36	.39	.45	.47	.53	.65	—	—	—	—	—	—	—	—	—	—
Bell-Mouth Inlet	C.I.	—	—	—	—	—	—	—	—	—	.44	.52	—	—	—	—	—	—	—	—	—	—
	Steel	.04	.07	.10	.13	.18	.26	.31	.43	.52	.67	.95	1.3	1.6	2.3	2.9	3.5	4.0	4.7	5.3	6.1	7.6
Square-Mouth Inlet	C.I.	—	—	—	—	—	—	—	—	—	.55	.77	—	1.3	1.9	2.4	3.0	3.6	4.3	5.0	5.7	7.0
	Steel	.44	.68	.96	1.3	1.8	2.6	3.1	4.3	5.2	6.7	9.5	13	16	23	29	35	40	47	53	61	76
Reentrant Pipe	C.I.	—	—	—	—	—	—	—	—	—	5.5	7.7	—	13	19	24	30	36	43	50	57	70
	Steel	.88	1.4	1.9	2.6	3.6	5.1	6.2	8.5	10	13	19	25	32	45	58	70	80	95	110	120	150
Sudden Enlargement	C.I.	—	—	—	—	—	—	—	—	—	11	15	—	26	37	49	61	73	86	100	110	140
	Steel	—	—	—	—	—	—	—	—	—	—	—	—	—	—	—	—	—	—	—	—	—

$$h = \frac{(V_1 - V_2)^2}{2g} \text{ feet of liquid; if } V_2 = 0 \quad h = \frac{V_1^2}{2g} \text{ feet of liquid}$$

NOTE: Tables shown for steel pipe and cast-iron pipe are for example purposes only. For equivalent head loss through valves and fittings for other materials, consult the manufacturer.

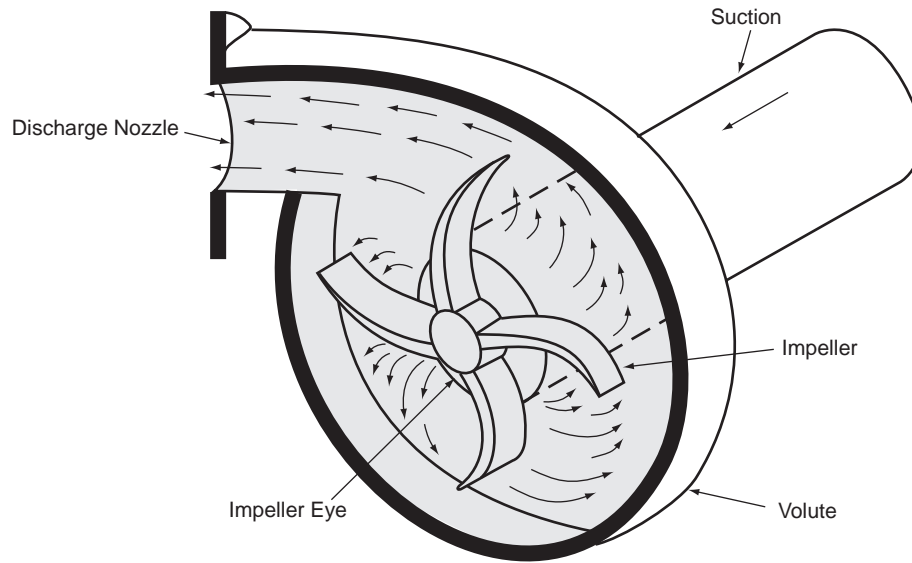

Figure 6-2 Volute-type centrifugal pump

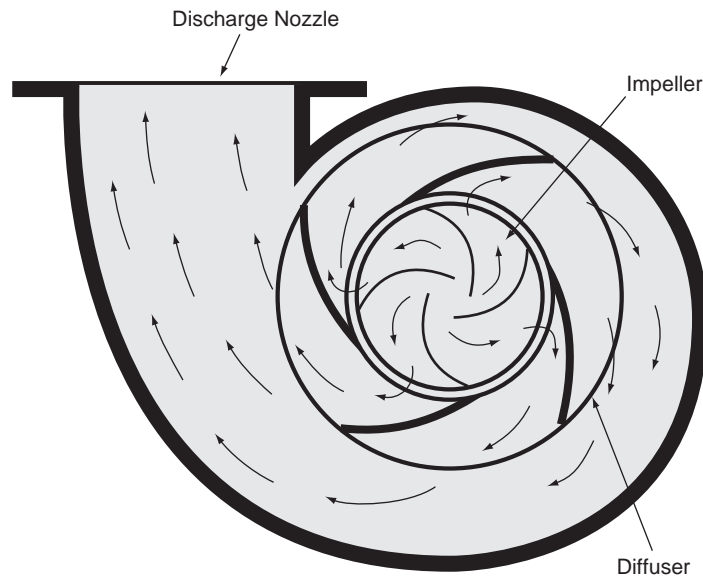

Figure 6-3 Diffuser-type centrifugal pump

Rotation of the impeller creates centrifugal force that moves liquid to the pump's outer case. Low pressure is created at the eye of the impeller (Dougherty and Franzini 1977). If this pressure is lower than atmospheric pressure, the water will be pushed into the space between the blades of the impeller and fluid can be pumped.

The total suction lift, or well depth below the pump centerline, that can be pumped is regulated by the atmospheric pressure. Using Eq. 6-1, when atmospheric pressure is 14.7 psi and a perfect vacuum is present, this pressure could support a column of water

Table 6-4 Maximum practical suction lift, in ft, for single-stage centrifugal pump

Elevation Above Sea Level <i>ft</i>	Maximum Practical Suction Lift, <i>ft</i>										
	Temperature of Water, °F										
	60	70	80	90	100	110	120	130	140	150	160
0	22	20	17	15	13	11	8	6	4	2	0
2,000	19	17	15	13	11	8	6	4	2	0	
4,000	17	15	13	11	8	6	4	2	0		
6,000	15	13	11	8	6	4	2	0			
8,000	13	11	9	6	4	2	0				
10,000	11	9	7	4	2	0					

equal in length to $14.7 \times 2.307 = 33.9$ ft (Stewart 1977). If the centrifugal pump could produce a perfect vacuum, the total theoretical lift would be 33.9 ft. Because a perfect vacuum at sea level is impossible to produce with a pump, the practical suction height varies from 60 percent to 85 percent of the theoretical possible distance, depending on the efficiency of the installation. As altitude increases, the suction lift decreases. Typically 24.7 ft is the maximum assumed (Stewart 1977). Table 6-4 presents values of the practical suction lift, in feet, for a single-stage centrifugal pump operating at different elevations. Because the use of a single-stage centrifugal pump is restricted to shallow wells (less than 20-ft [6-m] depths), multiple stages or different configurations are used. Other types of pumps are needed for deeper wells. On the discharge side, centrifugal pumps can be used to overcome 1,000 ft of head at high capacity.

Reciprocating Pump

The oldest type of deep-well pump is the reciprocating or plunger-type pump (Figure 6-4). The reciprocating pump consists of a belt- or gear-driven head located above the highest water level in the well. A pulley drives a pinion shaft and, through suitable gearing, the plunger rod works up and down in the well (Driscoll 1986). The prime mover is connected to the working, or pumping, barrel by pump rods.

The working barrel may be single or double acting. In the single-acting type, a check valve is located at the bottom of the cylinder and a similar valve is located in the plunger. The water flows into the working barrel through the check valve while the plunger is making its upstroke. On the downstroke, this water is held in the working barrel by the foot valve, and the plunger descends to the bottom of the barrel while the water passes through the valve in the plunger (Stewart 1977). On the next upstroke, the valve in the plunger closes, and the water above it is raised into the discharge pipe. At the same time, the foot valve opens and the cylinder again fills with water.

In small-diameter wells, a check may be set in the casing below the water level and the plunger sized to the casing, which then becomes the working barrel cylinder. In this case, the rods work through a stuffing box at the top of the casing, and water is discharged out of a side-opening tee.

Double-acting cylinders discharge water on each downstroke and upstroke of the working head. Double-acting pumps are capable of producing about 60 percent greater flow than pumps equipped with single-acting working barrels.

The capacity of this type of pump depends on the displacement of the liquid in the working barrel and the number of strokes per minute of operation. The pump is theoretically suitable for pumping wells of any depth, such depth being dictated by strength of material, power source, and economics.

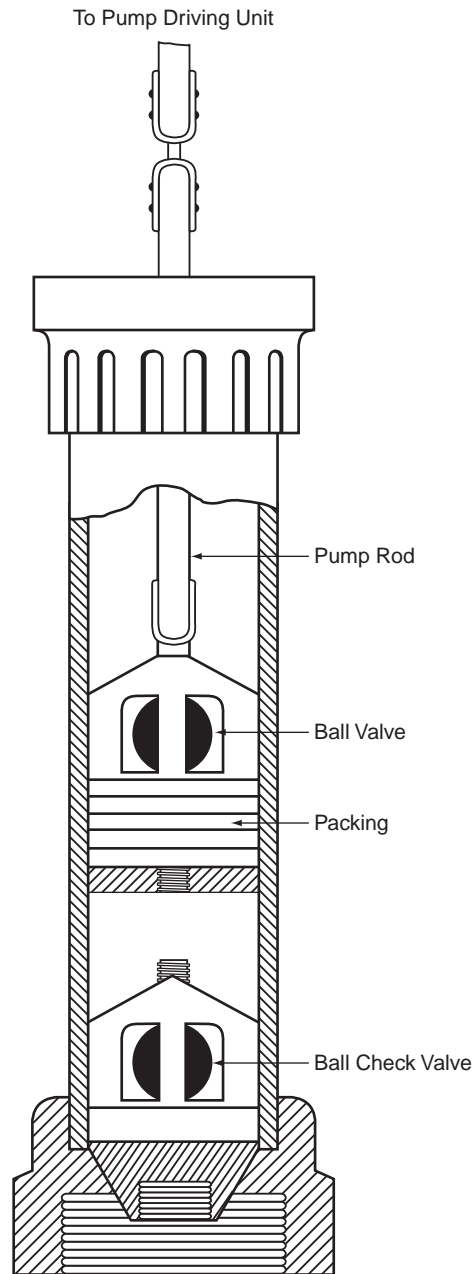

Figure 6-4 Plunger-type pump

Deep-Well Turbine Pump

Suction limited the use of centrifugal pumps until it was realized that these pumps more efficiently “pushed” water. As a result, centrifugal pumps can be used for high head and high capacity (Driscoll 1986). Consequently, the centrifugal pump has replaced the reciprocating pump as increased water volumes from deeper wells became necessary. Diminishing water tables, excessive costs of developing the deep pits that are used to place centrifugal pumps within reasonable suction lifts, and difficulty in providing efficient drivers fostered development of the deep-well turbine pump. The deep-well turbine

pump is not truly a turbine, but a combination of several stages of centrifugal impellers connected in series to a common shaft. The deep-well turbine pump as illustrated in Figure 6-5 consists of the following:

- a prime mover
- a suitable shaft and bearings connecting the power source on the surface to impellers located under the well water
- a series of impellers mounted in the bowl assembly at the lower end of the column that produces the required pressure head
- a discharge column pipe that channels water to the surface and acts as a housing and guide for the bearings and shaft assembly

The deep-well turbine pump was designed for capacities as low as 10 or 15 gpm (40 or 60 L/min) and as high as 25,000 gpm (95,000 L/min) or more, and for heads up to 1,000 ft (300 m). Most applications involve smaller capacities.

The pump illustrated in Figure 6-5 is a three-stage design. Each stage consists of a bowl, impeller, and diffuser manufactured as a standard unit. The number of bowls required for a particular installation depends on the dynamic head. The head determines the number of stages that must be provided. For large capacities, more than one pump may be needed. The capacity of the pumps used for bored wells is limited by the physical size of the well casing and by the rate at which water can be drawn without lowering its level to a point of insufficient pump submergence.

Submersible Pump

A submersible pump is actually a turbine pump with its motors close-coupled beneath the bowls of the pumping unit (Driscoll 2006; Driscoll 1986). The entire unit is installed under water. This construction eliminates the need for the surface motor, long drive shaft, shaft bearings, and lubrication system of the conventional turbine pump. Submersible pump motors are cooled by water flowing vertically past the motor to the pump intake. The motor is usually longer and of smaller diameter than a surface motor of the same horsepower (Driscoll 1986). Generally, the flow capacity for submersible pumps ranges from 1,000 gpm to 4,500 gpm; however, when a large-capacity submersible pump is needed, the manufacturer should be consulted for specific design and installation recommendations. Submersible pumps are used in wells more than 20 ft deep. Driscoll (1986) notes that submersible pumps are used at depths of over 2,000 ft at high capacities.

The purchase and installation costs for a submersible pump may be higher or lower than for a conventional pump, depending on setting depth, required head and capacity, water corrosivity, and other factors. Operating costs may also be higher or lower, based on motor efficiency, column bearing, hydraulic losses, cable losses, setting depth, and similar factors. A thorough analysis of all factors should be performed to compare surface and submersible motor-driven deep-well pumps for a specific installation.

Some inherent advantages of submersible pumps include (Driscoll 1986)

- use in crooked well casings that are unsuited for other types of pumps
- use in wells subject to flooding; the wells can be completely sealed
- minimization of surface equipment
- silent operation

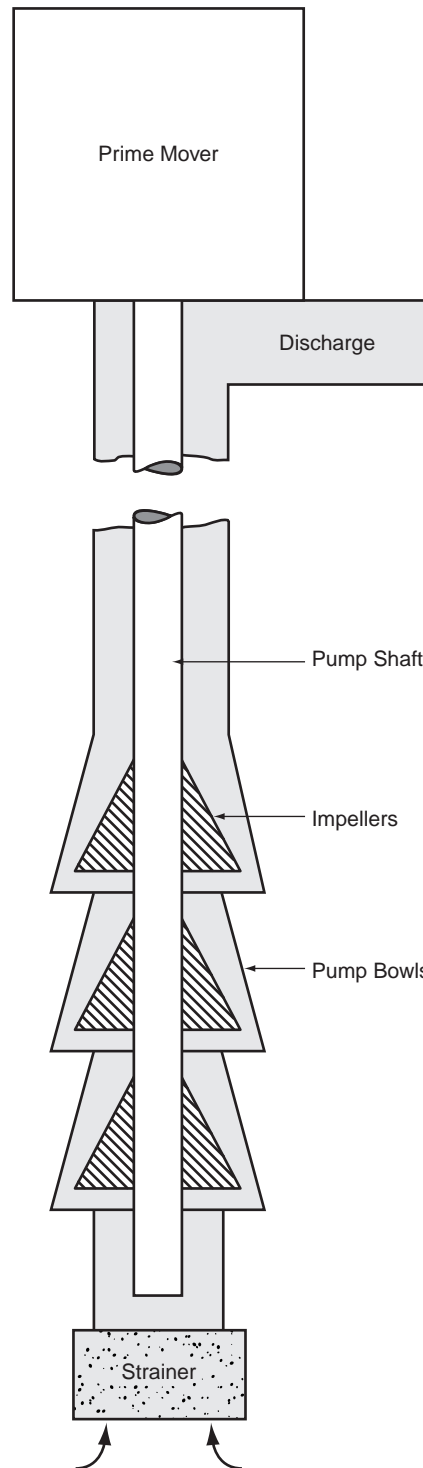

Figure 6-5 Vertical deep-well turbine pump

Propeller and Mixed-Flow Pumps

Propeller, axial flow, mixed flow, screw, and spiral type pumps have found limited use in shallow wells. These designs have open impellers, similar to a ship's propeller, and can be installed where flow is generally greater than 300 gpm (1,100 L/min), but where heads are under 40 ft (10 m). These pumps are used mostly for mixing chemicals as opposed to pumping water.

Rotary Pump

A rotary pump combines the positive-discharge characteristics of the reciprocating pump with the constant, steady discharge of a centrifugal pump. Although a rotary pump uses a rotating element and appears similar to a centrifugal pump, positive-displacement causes the pumping action. Specially designed runners squeeze the water between them as they rotate, building direct water pressure.

A well-designed rotary pump will create a relatively high vacuum, comparable to a centrifugal pump. However, rotary pumps are usually not as efficient as centrifugal pumps. Rotary pumps need to be well-designed and constructed of the best material or they will wear much faster. However, the rotary-type pump is widely used.

Rotary- or Positive-Displacement Pump

A rotary-displacement pump (a positive-displacement pump) is designed especially for relatively low capacities and for cased wells that are 4 in. and 6 in. (100 mm and 150 mm) or larger. Displacement of a piston in a cylinder of indefinite length causes the fluid flow (Driscoll 1986). Figure 6-6 illustrates the pumping element, which consists of a main body made up of a stator and rotor, both of helical form, and the driveshaft assembly. The helices are worm threads; the stator has a double thread, and the rotor a single thread.

As the rotor rolls on the inner surface of the stator, liquid is squeezed ahead by the rolling action, with minimum turbulence. The rotor is made of heat-treated stainless steel that has a hard, chrome surface to resist corrosion and abrasion. A one-piece bronze strainer with a rubber-seated foot valve keeps the column full of water, and no prelubrication is necessary (Stewart 1977). The stator is made of cutless rubber and is highly resistant to abrasion. Grit momentarily depressed into the rubber by the rotors is washed away by water, when the rotor is released.

Rotary-Gear Pump

A rotary-gear pump consists of two moving parts, which are the pumping gears (Stewart 1977) (see Figure 6-7). These gears rotate in an accurately fitted case with close tolerance to ensure efficiency. The teeth of the pumping gears move away from each other and pass the inlet port at point A in Figure 6-7. This movement produces a partial vacuum by withdrawing air into the pump, where it is carried between the teeth of the pumping gears around both sides of the pump case at point B. The action of the teeth meshing at point C results in a condition similar to a valve forming a seal that forces the water into the discharge line.

Water flow is continuous and steady in a rotary-gear pump. The size of the pump and the rotational speed of the pump shaft determines the quantity of liquid pumped per hour. All internal parts, including the bearings, are lubricated by the flow of water. The rotary-gear pump is suitable for suction of 22 ft to 25 ft (7 m to 8 m).

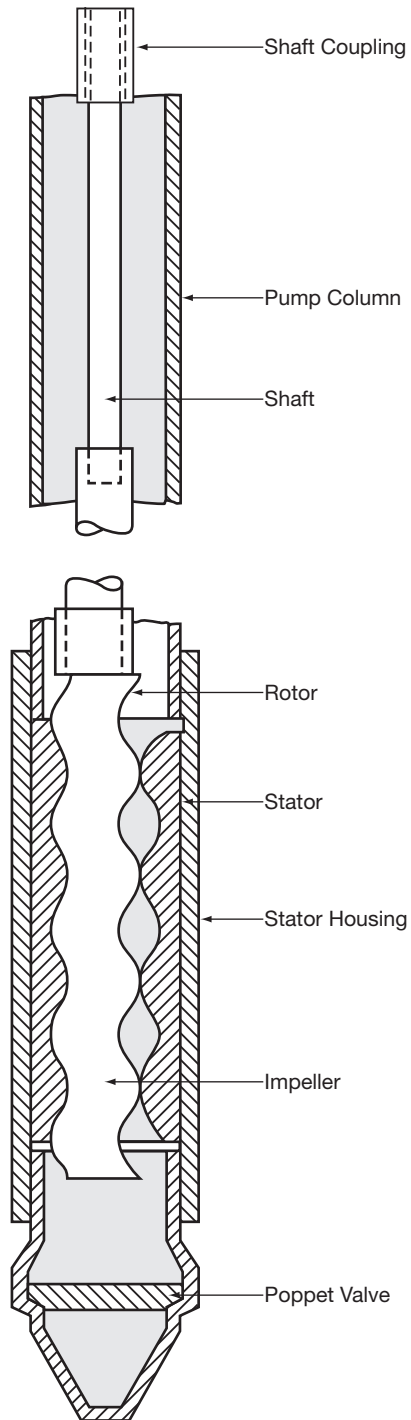

Figure 6-6 Rotary-displacement pump

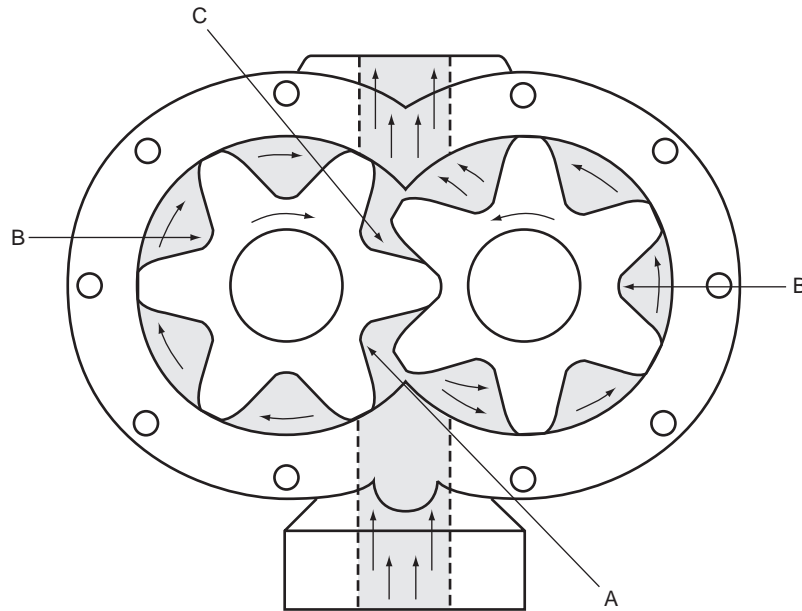

Figure 6-7 Rotary-gear pump

Impulse Pumps

Impulse pumps produce pumping action by directly applying pressurized air or water. Airlift and jet impulse pumps are discussed in the following paragraphs.

Airlift pumps. Airlift pumps have capacities up to 2,000 gpm (8,000 L/min) and head to 1,000 ft (300 m). They are rarely used in water wells, except those containing sandy or corrosive fluids. The pump consists of a vertical pipe submerged in the well and an air-supply tube that feeds compressed air to the pipe at a considerable distance below the static water level. The mixture of air bubbles and liquid, lighter in weight than the liquid outside the pipe, rises in the pipe. A continuous flow of mixed water and air emerges at the top of the pipe, and new liquid from the well enters the pipe at the bottom (Figure 6-8).

Because the only head-producing mechanism is the difference in specific weight of the water-air mixture inside the pipe and the water outside the pipe, the head that can be obtained from an airlift pump depends on the distance between water level in the casing and the elevation at which air is introduced. If head, H , is measured from the discharge pipe to water level and submergence, S , is measured from water level to introduction of air, the ratio H/S is approximately 1 for most applications. The ratio can reach 3 for high heads (and low flows) and be as low as 0.4 for low heads (and high flows).

The volume of water pumped depends on the amount of air supplied. The pumping capacity increases with the amount of air supplied, up to an optimum. Because the discharge is a mixture of liquid and air, more air than optimum actually decreases the volume of water. Table 6-5 indicates approximate amounts, in cubic feet per minute, of free air required to pump 1 gpm of water against the heads of relative submergence shown.

The advantages of airlift pumps include

- no moving parts
- usability for corrosive and erosive fluids
- gentle action (has been used to remove sand from buried undersea objects)
- operation on air (can be used in explosive atmospheres)

- ability to be placed into wells of irregular shape where regular deep-well pumps cannot fit

The disadvantages of airlift pumps include low efficiency (less than 40 percent) and the need for very large submergences compared to conventional pumps (Driscoll 1986).

Jet pumps. The jet impulse pump is shown in Figure 6-9. Water is forced down through a nozzle, forming a jet, and is discharged into the throat of a venturi diffuser at high velocity (Driscoll 1986). The jet, or ejector nozzle, converts the pressure into velocity. Water discharges into the diffuser, causing a low-pressure area. Water then flows in from the well and mixes in the diffuser with the driving water. While passing through the tube, most of this high velocity is transformed into pressure, and this delivers both the driving water and the water draw from the well to a high elevation (Driscoll 1986).

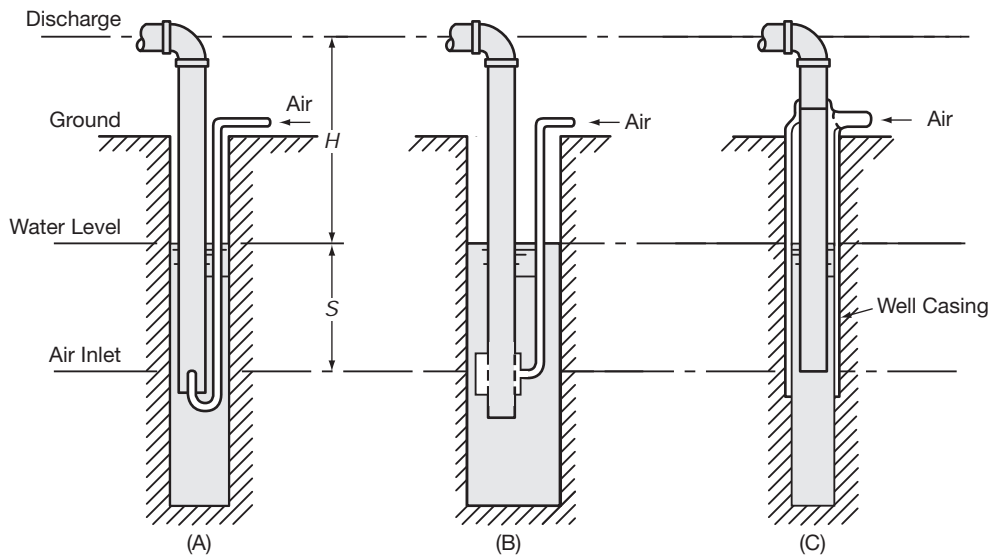

Figure 6-8 Airlift pump: (A) bottom inlet; (B) side inlet; and (C) casing inlet

Table 6-5 Air requirements* for airlift pumps

$H \setminus H/S^\dagger$	3	2	1	0.67	0.4
20				0.22	0.15
50				0.3	0.2
100				0.4	0.3
150			0.7	0.5	
200			0.8	0.6	
300		2.1	1.0		
400		2.3	1.2		
500	3.25	2.6	1.4		
650	3.75	3.0	2.1		
800	4.2	3.5			
950	4.7	3.9			

*Number of cubic feet per minute of free air required to pump 1 gpm of water.

[†] H = head; S = submergence, in feet.

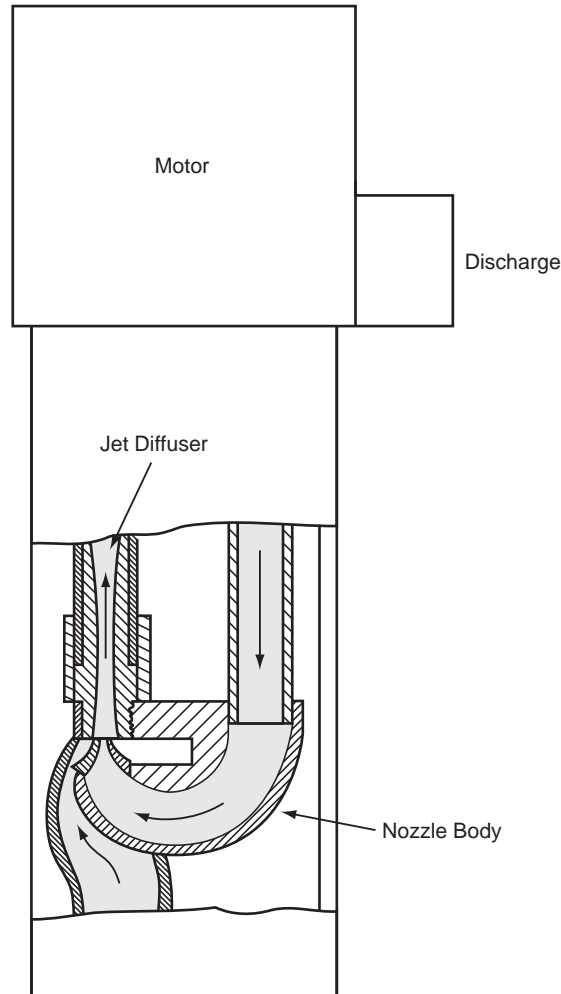

Figure 6-9 Jet-type deep-well pump

The efficiency of this type of pump is rather low, about 25 to 30 percent, but the pump has no moving parts submerged in the well and is efficient where high capacities are not required. A jet pump is best used for a lift of 25 ft (8 m) or more and capacities less than 50 gpm. This pump is often used for 120 to 150-ft (40 to 50-m) lifts. In deeper wells, jet-pump efficiency becomes very low and another type of pump should be used. Jet pumps are light and can pump very muddy or sand-loaded water. Centrifugal-jet pump combinations have been used to pump wells as deep as 400 ft (120 m); centrifugal pumps alone usually are limited to 20- to 25-ft (6- to 8-m) well depths.

Table 6-6 summarizes the types of pumps discussed in this chapter.

OPERATING CONDITIONS

Continuous operation of a pump is generally preferable to intermittent operation, but varying water demand usually requires some combination of off and on time. For improved well performance and pump life, system components and storage capacity should be designed to minimize the number of pump starts and stops per day. While pump starts

Table 6-6 Summary of pump types and applications

Pump Type	Flow Capacity	Maximum Head	Application	Additional Notes
Centrifugal	Can be almost any flow volume	Suction 24.87 ft (7 m) SI charge head— 1,000 psi	Shallow wells unless additional stages are added	60–85% efficiency
Reciprocating	Depends on liquid displacement	Depends on material and power source	Shallow, typical chemical feed	
Turbine	10–25,000 gpm (40–95,000 L/min)	1,000 ft (300 m)	Deep wells	Has replaced the reciprocating pump for increased water volumes from deeper wells
Submersible	10–25,000 gpm (40–95,000 L/min)	2,000 ft	Deep wells/underwater installation	No surface motor, long drive shaft or lubrication system
Propeller and mixed flow	300 gpm (1,100 L/min)	40 ft (10 m)	Limited use in shallow wells	Open propeller system
Rotary	Low	High	Widely used	Less efficient than centrifugal
Rotary displacement	Low capacities	High	Chemical feed	
Rotary gear	Depends on size of pump and rotational speed of shaft	Suction: 22–25 ft (7–8 m) Discharge 1,000 psi	Varies	Internal parts are lubricated by flow of water Water flow is continuous and steady
Impulse				No moving parts, gentle action, fit irregularly shaped wells, low efficiency
Air lift	2,000 gpm (8,000 L/min)	1,000 ft (300 m)	Water wells containing sandy or corrosive fluids	
Jet pump	50 gpm	25–150 ft (8–50 m)	Individual wells, or well drilling	

should be minimized, starting a pump several times per day or more than once per hour adds only slightly to power consumption and normally gives acceptable life to pumps, motors, and controls.

For continuous running, a pressure-regulating valve or variable-speed drive is used that can match the pump output with the system demand. Such systems usually run at very low efficiency during low-demand periods. The overall cost of equipment and operation should be thoroughly analyzed before adopting such a system.

To achieve the lowest-cost operation, a system must run its pump and motor or engine in the best efficiency ranges. Proper system components can assure this, but changing conditions sometimes justify altering or reselecting components to maintain economical operation.

For each type of pump and prime mover, the operating conditions must be checked against manufacturers' application information to ensure reliable operation. These operating conditions include the ambient air and water temperature ranges, pressures, flow, corrosive and abrasive factors, power supply variation, duty cycle, and protective devices.

PUMP SELECTION

Pump selection primarily depends on economics. The type of pump selected should give the best and most economical service over a prescribed number of years, when pumping under specific conditions. Before selecting a pump, different types of pumping arrangements should be investigated. For each arrangement, the design engineer should tabulate the initial cost, cost of installation, cost of operation, cost of maintenance, and expected equipment life. The combination that offers minimum investment and operational costs and fulfills system requirements should be obvious from the design engineer's table.

Factors in Pump Selection

Some factors that must be considered before selecting a particular pump include the following (Driscoll 1986):

- Capacity
- Depth of well and pumping level
- Inside diameter of well
- Condition of borehole (straight or crooked)
- Chemical and abrasive properties of the water (water quality)
- Total head
- Type of available power
- Costs

After a well has been tested for yield, operation requirements are dictated by demand. For some wells, a constant drawdown prevents issues such as sudden changes in water quality or occurrence of sand. The size and condition of the well borehole are very important. For example, if a well is too crooked for efficient operation of a deep-well turbine pump and use of a plunger-type pump is not desirable, a submersible pump may be economical, even though initial installation might be more expensive. A chemical analysis will determine if the pump needs to be built with materials to resist corrosion. Total head must be determined to lift or push the water to ground-surface elevation and to storage or delivery. Sufficient head needed to perform both tasks determines the pump horsepower required for accurate cost estimation.

Measuring pump performance. Energy cost is one of the principal expenses in pump operations. Pumps should be monitored to ensure that they are operating at or near peak efficiency. Total head, input horsepower, and quantity of water pumped must be measured.

The total dynamic head is the vertical distance from the water level in the well, while pumping, to the center of the free-flowing discharge, plus all losses between the point of entry of the water and the point of discharge. Losses in pipe can be obtained from Table 6-2, and pump-column losses are available from pump manufacturers' catalogs.

Water horsepower is the work required to lift a weight of water to a defined height per unit of time. The water horsepower required to pump water can be determined by the following equation (AWWA 2010):

$$\text{whp} = \frac{Q \times H_T}{3,960} \quad (\text{Eq. 6-2})$$

Where:

- Q = the flow rate, in gpm
- H_T = total head, in ft

The horsepower calculated using Eq. 6-2 is for all equipment (pumps, prime mover, and the like) operating at 100 percent efficiency. Because 100 percent efficiency cannot be attained, the brake horsepower, or horsepower necessary at the pump shaft, is used. Brake horsepower can be obtained from manufacturers' data tables or performance curves. The pump efficiency E_p can be calculated from Eq. 6-3 (AWWA 2010):

$$E_p = \frac{\text{whp}}{\text{bhp}} \quad (\text{Eq. 6-3})$$

The total horsepower required to operate the system is motor horsepower from Eq. 6-4:

$$\text{mhp} = \frac{\text{bhp}}{E_M} = \frac{Q \times H_T}{3,960 \times E_p \times E_M} \quad (\text{Eq. 6-4})$$

Where:

E_M = the efficiency of prime mover

The efficiency of an electric motor as a prime mover is usually between 60 percent and 95 percent, depending on size and type, but an exact value can be obtained from manufacturers' information.

The overall efficiency of a pump system depends on many factors, such as specific speed, relative size, service materials, and physical characteristics of fluid. Large centrifugal pumps have developed more than 92 percent efficiency. The efficiency of smaller pumps may, in some instances, be only 20 or 25 percent.

To determine the overall efficiency of a pumping system, the efficiency of the pump, prime mover, and drive need to be included. The overall efficiency E can be determined with Eq. 6-5.

$$E = E_p \times E_M \times E_D \quad (\text{Eq. 6-5})$$

Where:

E_p = efficiency of the pump

E_M = efficiency of the prime mover (motor)

E_D = efficiency of the drive, as given in manufacturer literature

After determining the overall efficiency, E , the actual power required can be determined as follows (AWWA 2010):

$$\text{power required} = \frac{\text{theoretical power required}}{E} \quad (\text{Eq. 6-6})$$

If an electric motor is used to drive the pump, the actual power required will be equal to the result of Eq. 6-6, divided by the electrical motor efficiency (see manufacturer literature). The result is that the wire to pump power is the pump power divided by both pump and motor efficiency. The wire demand can be substantially higher than the water pumping requirement for small systems, but should be 1.3 to 1.5 times water power needs for larger, more efficient systems.

To determine the cost of operation, one must convert horsepower to watts. One horsepower is equivalent to 746 W and 1 kW is equal to 1,000 W; thus,

$$\text{kW}\cdot\text{h demand} = \frac{Q \times H_T \times 0.746}{3,960 \times E} \quad (\text{Eq. 6-7})$$

Power is usually sold in units of kilowatt-hours, and when Eq. 6-7 is multiplied by number of hours used, Eq. 6-8 is created

$$\text{kW}\cdot\text{h} = \frac{Q \times H_T \times 0.746 \times \text{hours}}{3,960 \times E} \quad (\text{Eq. 6-8})$$

Total costs can be determined by multiplying Eq. 6-8 by cost per kilowatt-hour.

$$\text{total cost} = \frac{Q \times H_T \times 0.746 \times \text{hours} \times \text{cost/KW}\cdot\text{h}}{3,960 \times E} \quad (\text{Eq. 6-9})$$

or

$$\text{power cost per hour} = \frac{Q \times H_T \times 0.746 \times \text{cost/KW}\cdot\text{h}}{3,960 \times E} \quad (\text{Eq. 6-10})$$

If a different type of power is used, cost per hour can similarly be calculated. Standby equipment also should be provided.

In general, pumps are driven by direct connection to prime movers or through right-angle drives or belts. Electric motors and gasoline or diesel engines usually are prime movers for water-well pumps.

Operational Limits of Pumping Units

In a well that is clean and free of sand or grit, a rotary-type pump may perform as satisfactorily as a centrifugal pump, but rotary units are applicable only for operations that present low flow rates. Suction-lift specifications for rotary-type pumps are the same as for centrifugal pumps.

A centrifugal and jet, or ejector, combination pump can produce low rates of flow and suction lifts to 120 ft (37 m). In deeper wells, jets sometimes are used in combination with positive-displacement pumps.

For capacities exceeding a few gallons per minute (10 or 11 L/min) and settings deeper than 30 ft (9 m), a multiple-stage deep-well turbine pump that is driven directly by a submersible motor or through shafting by a surface-mounted motor or engine is usually selected. The choice between submersible and surface-driven turbines should be based on the following:

- Analysis of initial costs and operating costs
- Acceptability of aboveground structures and noise
- Likelihood of vandalism
- Well conditions
- Available power
- Other factors specific to a particular installation

Except for positive-displacement pumps, the discharge head increases as the rate of flow or capacity decreases, and the discharge head decreases as the rate of flow or capacity increases. If constant discharge under a varying head is to be maintained by a centrifugal pump, a variable-speed drive must be used. No problem is encountered when a positive-displacement pump is used because the capacity depends on the speed of the pump. The pressure that can be developed by a plunger-type pump is limited only by the size of the power unit and strength of materials.

ELECTRIC MOTOR SELECTION

Electric motors are usually selected according to National Electrical Manufacturers Association standards, which include requirements for enclosures and cooling methods. An electrical specialist should be consulted for advice and assistance in selecting electric motors. AWWA Manual M2, *Instrumentation and Control*, also provides information on electric motors.

PUMP INSTALLATION

Proper pump installation increases pump efficiency, minimizes maintenance, and prolongs the life of piping. This section covers installation of pumps and associated piping.

Aboveground Installation

A good foundation, preferably concrete, should be constructed for pump placement. Foundation bolts should be placed according to the dimensions that are usually furnished by pump manufacturers. The pump must be easily accessible for regular inspection. Room should be provided for use of a crane, hoist, or tackle. Pits in which pumps are placed should be safeguarded against flooding.

Alignment. Pumps should be properly aligned by leveling the base with shims. Most pump bases, no matter how rugged, will spring and twist to some degree during shipment. Consequently, alignment is crucial when the unit is being installed.

Piping should line up naturally and be supported independently of the pump to eliminate strain on the pump casing; it should not be forced into place with flange bolts. The piping should be isolated from the pump head with a dresser coupling near the head. After the piping has been installed, alignment should be rechecked. On unusually long discharge lines, a packed slip joint should be installed to compensate for elongation of pipe that might result from pressure or temperature changes.

Piping. To protect the pump, a gate valve and check valve should be installed in the discharge pipe close to the pump. The check valve should be placed between the pump and a gate valve. If pipe connections are used on the discharge end of the pump to increase the size of discharge piping, the connections should be placed between a check valve and the pump. The selection of the discharge piping should be made with due reference to expected friction losses.

After the piping has been completed, alignment should be checked again using a straight edge and thickness gauge. The manufacturer's installation checklist and adjustment directions should be closely followed and double checked before applying power to the pump unit. When pumping units have been aligned before piping is completed, piping strains that develop are probably the cause of any misalignments. Changes should be made accordingly. If stuffing boxes are adjusted properly and the pump and drives are aligned properly, the unit can usually be operated by hand with ease.

Deep-Well Installation

A deep-well pump driven by either a submersible motor or an aboveground driver must be installed according to the manufacturer's instructions. The pump must be sized and set so that it will never run for a few minutes with no delivery, which could occur if excessive drawdown is present or if the pumping level is lowered to the intake area. Running with little or no delivery is likely to damage the pump bearings (if they run long enough to heat up and boil) and cause overheating failure of a submersible motor. If the well drawdown or the delivery system could cause the pump to run with little or no delivery, protection

should be provided to ensure flow. Such protection could be in the form of a flow switch or well-level switch that would shut off the pump or sound an alarm if flow or water level dropped below a safe minimum. The minimum water level above the pump intake should always be kept greater than the required suction head (NPSH) specified by the manufacturer.

The materials used in the pump and delivery system must be resistant to significant corrosion caused by normal water conditions in the well or any periodic chemical cleaning operations performed with the pump in place. Additionally, the well must be properly designed and developed before installing the production pump to minimize sand pumping. Most pump and submersible-motor warranties do not cover failures from abrasive damage and corrosion.

Check valve. Unless some unusual requirement prevents it, a check valve should always be installed within 25 ft (8 m) of a deep-well surface-driven or submersible pump. The check valve prevents problems that may occur when water in the delivery pipe flows back into the well when the pump is turned off. These problems include the following:

- Backwashing, which can disturb the stabilized particles located outside screens and perforations, often increasing sand and turbidity in the well.
- Backflow, which may spin the pump at high speed in reverse, causing damage or shortened life. This problem will not occur if the pump is designed to withstand high speed or if it is equipped with a device to prevent backspin. Attempting to restart a pump during backspin decreases bearing life and may cause tripping of protective devices with prolonged starting current.
- Refilling of the delivery pipe at each start, which wastes power.
- Creation of a vacuum and water hammer. Aboveground check valves and shut-off valves near the pump, which are often required, can create a vacuum in a section of the delivery pipe after the pump turns off. This occurs because atmospheric pressure can only support water in the pipe to less than 34 ft (10 m) above the level in the well. When this evacuated section refills on starting, the moving water striking the stationary water at the closed valve creates a severe hydraulic shock (water hammer), which can cause pipe, valve, pump, or motor failure. An air and vacuum release valve should be installed between the pump head and the check valve.

Additional check valves may be required, depending on setting depth, valve rating, and aboveground equipment. A check valve in the delivery pipe of a submersible pump will hold the pipe full of water if the pump is removed from the well. Special check valves are often used in which a small replaceable plug can be broken off to create a drain by dropping a weight down the well before pulling the pump.

The manufacturer's installation documentation for surface-driven, deep-well pumps includes information about the following:

- Column pipe assembly
- Bearings and shafting
- Lubrication
- Alignment
- Mounting and aligning of the aboveground drive
- Setting of the impeller position
- Use of proper controls

The manufacturer's installation documentation for submersible pumps includes information about the following:

- settings that prevent motor burial in sand or silt
- water temperature and flow past the motor to provide proper cooling
- use of cable and splices that meet the amperage and voltage requirements
- pipe tightening to prevent unscrewing by motor-starting torque
- clamping of cable to delivery pipe
- proper controls and protections
- necessary checks before, during, and after installation

REFERENCES

- American Water Works Association (AWWA). 2010. *WSO: Basic Science Concepts and Applications*, 4th Ed. Denver, Colo.: AWWA.
- Daugherty, R.L. and J.B. Franzini. 1977. *Fluid Mechanics with Engineering Applications*. New York, N.Y.: McGraw-Hill Book Company.
- Driscoll, 1986. *Groundwater and Wells*, 2nd Ed. Minneapolis, Minn.: Johnson Filtration Systems.
- Hicks, T.Y. and T.G. Edwards. 1971. *Pump Application Engineering*. New York, N.Y.: McGraw-Hill Book Company.
- Jones, G.M., ed. 2006. *Pump Station Design*, 3rd Ed. Burlington, Mass.: Butterworth-Heinemann/Elsevier.
- Stewart, H.L. 1977. *Pumps*. Indianapolis, Ind.: Theodore Audel & Co.

Operations Problems, Well Plugging, and Methods of Correction

Wells usually provide relatively consistent, maintenance-free water supplies over many years, however, maintenance is an ongoing issue. While water supply wells provide good service to most utilities for many years, wells are subject to fouling and other performance problems. These concerns include

- mechanical failures, including failures of electrical motors and pumps, and failures of valves.
- poor operating and maintenance procedures.
- poor well design and construction practices including insufficient placement of grout, improper design of pumps, valves, fittings, and excessive drawdown allowances.
- hydrogeologic constraints that are unassessed at the time of design or change over time, such as sand, clay, or rock layers that are unstable and collapse into the borehole; naturally occurring or induced fracturing and faulting; long-term water quality changes caused by changes to the hydraulic regime such as dams; water hammer to the aquifer; effects due to mining of the water or introduction of chemicals and microorganisms; and naturally occurring phenomena (such as sinkholes, karst terrain features, or faults).
- high silt or sand content caused by failure to develop the wells fully or intercepting sand or silt layers that have not or cannot be sealed off in the borehole or corrected in well design.

- plugging or fouling as a result of hydrogeologic, geologic, biological, geochemical, engineering, and construction factors. Natural deterioration may be exacerbated by operational choices and geochemical conditions.

These problems may exist in conjunction with, or as a result of, microbiological fouling problems in wells. Microbiological problems are often ignored by operational personnel because they are disguised by more obvious issues like corrosion and deteriorated equipment. Microbial issues can be controlled but not eliminated. Operators need to be cognizant of these issues and plan for ongoing maintenance.

The regular maintenance can increase the life of wells. As treatment technologies advance, and as the economics and sustainability of water facilities gains greater consideration, the need to review and correct well performance problems, especially fouling concerns, has become more significant.

This chapter provides a basic discussion of well performance and fouling problems, their causes, options for correction, and the economics of rehabilitating old wells. Three case studies are included at the end of the chapter that discuss fouling problems in detail, and corrective actions that were, or were not, taken.

EVALUATING WELL PERFORMANCE

Specific capacity may be the single most informative factor in routine evaluation of well performance. The specific capacity is the pumping rate (e.g., gallons/minute or liters/second) per unit (e.g., foot) of drawdown. When plugging problems occur, the drawdown increases and therefore, the specific capacity decreases despite the fact that the total yield of the well may not decrease significantly.

Specific capacity and changes in specific capacity are related to well performance parameters revealed by well performance analysis. These are the well and aquifer loss components of drawdown, which are derived during analysis of step-drawdown pumping tests (Krusemann and de Ridder 1994, or Bruin and Hudson 1955). Changes in these loss components can be used to determine whether well clogging is deep-seated (formation) or surficial (gravel pack and screen).

A related factor is the entrance velocity at which water passes through the well screen or the edge of the formation (depending on the type of well). As the entrance velocity increases, sand, silt, and colloidal matter can more readily enter the flow stream. Most rock wells that obtain water from fractures in aquifer rock have inherently high entrance velocities due to the small apertures of fractures. Screened wells developed in unconsolidated aquifers can be designed to provide a desired entrance velocity profile. A common screen design doctrine developed from experience with wire-wound screens (e.g., Sterrett 2007) is to design screens so that average entrance velocities are less than 0.1 ft/s on the assumption that flow at that velocity is essentially laminar to minimize the following:

- turbulence around the well screen
- precipitation of iron, manganese, and calcium
- particulates at the well screen

Other investigators (E.B. Williams 1981) have provided guidance regarding such concepts as entrance velocity. In general, a low entrance velocity can reduce pressure changes in the well and the release of dissolved gases in wire-wrapped well screens. However, in the West, D.E. Williams (1985) notes that wells using shutter screens with higher entrance velocities may not necessarily increase fouling problems. These higher velocities may be possible without increasing fouling problems due to site-specific water quality differences.

Investigators such as Williams (1981) have also discussed concepts such as approach velocity, which can also affect well and formation plugging. In any event, careful attention to these well design concepts can impact future well screen and formation fouling.

In addition, a low entrance velocity minimizes pressure changes in the well and facilitates the release of dissolved gases. Conversely, higher entrance velocities may reduce some fouling problems. Higher entrance velocities are seen as desirable in the engineering of long shutter-type screens common in the western United States.

POOR WELL PERFORMANCE

Several performance problems are caused by fouling or sand and silt production in wells. These problems and their likely causes are outlined below (Borch et al. 1993; Smith and Comeskey 2009):

1. Water level decline in the well
 - a. reduced hydraulic efficiency in the well, most commonly plugging or incrustation of the borehole, screen, or gravel pack
 - b. regional water level declines
 - c. well interference or plugging of a gravel pack by sand, silt, or clay
2. Lower specific capacity
 - a. drop in pumping water level, due to microbiological fouling, chemical precipitation, formation plugging, and pump corrosion
 - b. well field or regional water level declines (drought, reduced recharge, locally unsustainable pumping). Specific capacity is affected by change in aquifer transmissivity in unconfined aquifers, so if the static water level drops, transmissivity, and therefore specific capacity, drop.
3. Lower yield
 - a. dewatering or caving in of a major fracture or other water-bearing zone
 - b. insufficient development (resulting in lower specific capacity and higher well and aquifer loss)
 - c. lack of connection to water-bearing fractures (see '3b')
 - d. pump wear
 - e. impeller detachment from shaft
 - f. microbiological fouling, plugging, or corrosion and perforation of pump and column pipe
4. Sand/silt pumping
 - a. presence of sand or silt in fractures intercepted by well-completed open hole
 - b. leakage around casing bottom
 - c. inadequate screen and filter-pack selection or installation
 - d. screen corrosion
 - i. collapse of filter pack due to excessive vertical velocity and washout
 - ii. insufficient development
5. Silt/clay infiltration
 - a. inadequate seal around the well casing or casing bottom
 - b. infiltration through filter pack
 - i. "mud seams" in rock
 - ii. insufficient development

Many of these performance problems can be traced to inadequate design and/or construction (including lack of adequate development) of the well. Several operational conditions that are warnings of design problems are overpumping (which results in lowering of the water table), clogging or collapse of a screen or perforation of a screen section, corrosion, incrustation, and wear aggravated by excessive intake velocities. Other design and construction errors include

- poor selection of materials that lead to significant corrosion or collapse
- incorrect specification of pumps
- poor construction: casing cracks or leaks, leaking or missing grout, misplacement of screens and gravel pack, misalignment
- lack of well development: poor well yield, turbidity and sand pumping, biofouling, incrustation, and excessive drawdown

The well production rate is usually determined by the hydrogeologist, based on well performance and aquifer tests performed at the time of drilling (or shortly thereafter—see chapters 4 and 5). The hydrogeologist's recommendation should be respected. Overpumping an aquifer can damage the well by reducing the storage and production capacity of a groundwater system. Wells that are too close together increase drawdown and pressure loss in the formation. In compactible granular formations, the water-bearing formation will consolidate. As a result, compaction and consolidation result in a lower water table, less water storage space, reduced yield from individual wells, and collapse of the well casing.

It should be noted that an observed decrease in the capacity from a well may also be due to fouling/growth accumulation within the conveyance pipeline from the well that can restrict the effective pipe diameter, increasing head losses and reducing carrying capacity.

COMMON PUMP OPERATING PROBLEMS

Breaking Suction

No pump should operate at a rate at which it breaks suction, or actually exceeds its design net suction pumping head (NSPH). Besides damage to the pump (including cavitation that begins as the design NSPH is exceeded), the water level fluctuates violently when a pump breaks suction. The fluctuation creates a surge in the well and in the water-bearing formation outside the well. The force may collapse the well if it was not properly stabilized. A surge can also cause sand pumping. With the loss of suction, air is entrained with the water and causes it to appear milky. Air bubbles may also damage the distribution system piping by causing air pockets. A surge can dislodge corrosion products, slime layers, or other incrustated materials from the inside of the column or transmission pipes.

If a pump does break suction and cavitation starts or pumping stops, the discharge must be reduced by partially closing the discharge gate valve until the pumping level in the well remains above the pump bowls. Closing the valve increases the head loss in the system, causing the pump to work against a greater total dynamic head and decreasing flow. This procedure also wastes power. To regain efficiency, the pump is usually set deeper (if conditions permit) or one bowl and impeller is removed from the pump assembly to change the operating characteristics of the pump.

Causes

A lower pumping level in a well that has previously operated satisfactorily may result from the following:

- The water table (nonpumping level) in the vicinity of the well may have dropped so that the pumping level was correspondingly lowered.
- The intake portion of the well may have become clogged with incrusting material, so that greater drawdown had to be created to cause water to flow from the formation into the well at a given rate.

Lowered water table. The aquifer level in the vicinity of a well may recede seasonally or during long dry periods when recharge to the aquifer is at its minimum. An aquifer level is reduced if the stored groundwater is gradually depleted by pumping. The successive installation of additional wells in an area with overlapping cones of depression can also cause the water table to recede. A receding water table will cause significant mutual interference between wells, and the overlapping cones of depression would reduce the water levels of the wells. Consequently, water levels in the aquifer will be lowered to a point that is lower than that found in a single operating well.

Figure 7-1 illustrates the operating problem that results from a drop in the water table caused by any of these occurrences. Curve 1 represents the relationship between well yield and pumping level. Curves 2 and 3 represent lower pumping levels caused by recessions of the water table. The drawdown in each case is the difference between the depth to water at zero discharge and any other point on one of these curves. The limiting yield occurs where increase in yield ceases to be approximately proportional to increase in drawdown.

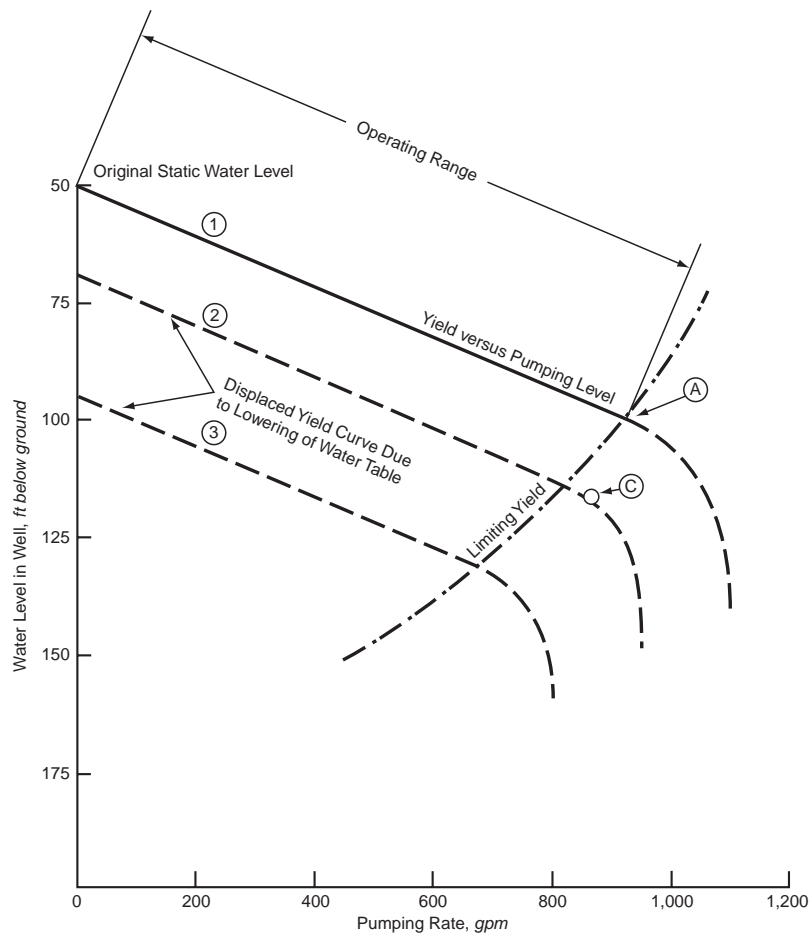

Figure 7-1 Operating problems resulting from a drop in the water table

With a pump operating at point A on curve 1 and a drop in water level that changes the well performance to curve 2, the same pump may operate at about point C. This undesirable situation can be improved only by cutting back the pumping rate to less than 800 gpm (3,000 L/min).

Clogged intake. When a pump cavitates or breaks suction, the water level fluctuates violently, producing a surge in the well and in the water-bearing formation outside the well. In very soft sandstone or a screened well not completely stabilized during construction, the surging action may dislodge fine materials and cause sand pumping.

If suction is lost, air becomes entrained with the water, causing it to appear milky. The discharge pulses, plus expansion of the entrained air bubbles, can reach the distribution system. Corrosion products or other incrustations can be dislodged from the inside of pipes and color the water. A loss of suction will interrupt the cooling effect of the water flow, resulting in the pump bearings heating up and eventually seizing.

Solutions

Water levels in all wells should be measured and recorded periodically or continuously. A continuing record of both nonpumping and pumping levels should be maintained. If the pumping level recedes in any well, the cause should be determined. The pumping equipment should be adjusted if danger of breaking suction becomes apparent.

PHYSICAL CAUSES OF WELL DETERIORATION

Water supply operators should evaluate any well failure or long-term decline in performance to determine if physical or mechanical problems are causing the decline. A review includes

- long-term drawdown trends
- changes in viscosity or water temperature from the baseline data
- pumping that exceeds the recharge rate
- interference of other well fields that are lowering the water levels
- pumping that exceeds the design capacity
- nonuniform flow through the well screen

The only way to determine if any of these factors is occurring is to monitor the aquifer levels and to perform specific capacity analyses on a regular basis. The specific capacity should be determined at least annually on each well, and the analysis should occur only after the well is allowed to fully recover. Then, the well should be run for an hour to determine specific capacity. The result is compared to the original data and plotted to show trends.

Evidence of a physical problem when the specific capacity declines include

- increased air in the discharge
- increased sand, colloids, or other turbidity in the water pumped
- excessive wear on the pump
- increased color or settlement around the well, which may indicate large quantities of sand removal

Particulates, incrustation, calcium carbonate, or corrosion are the main causes of these visible changes.

Particulate Plugging

Sand, silt, or colloidal matter drawn into a well or well screen will plug the screens and gravel versus filter packs (if present), providing less open area through which to draw the water. Plugged screens increase the entrance velocity of the raw water, which can increase particle movement as well as drawdown. Particulates in the water tend to wear out well screens, increase pump wear, and decrease water quality.

In most cases, particulate plugging is caused by poor well design, including insufficient development of the well or inadequate formation sampling that leads to poor screen location and/or pumping the well at rates that increase the entrance and approach velocities that can mobilize sand and silt particles within the formation lying outside the well screen and gravel-pack filter. In some cases, the logging may not have been sensitive to thin layers of sand, silt, or colloidal matter that now may be exposed. In wells with gravel packs, incomplete development or over-pumping may be indicated by plugging of the gravel pack and the screens. Consistent production of sand or silt in a well can collapse the formation above the screen, or worse, at the surface. Particulates also form a nucleus for chemical incrustation on a screen or column.

Plugging by Iron and Manganese

At a pH less than 5.0, iron (Fe) and manganese (Mn) remain dissolved as Fe^{+2} and Mn^{+2} in the water supply. As pH increases, however, at high redox potentials or with the presence of dissolved oxygen (2–3 mg/L), these constituents convert to Fe^{+3} and Mn^{+4} . These metals can collect around the well screen in an insoluble mass as metal oxide mineral deposits. This precipitation will form nodules that collect additional ferric or manganic precipitates. Oxygenated water (used to lubricate pumps) or increased turbulent flow in the well screen vicinity aggravates iron precipitation and encourages the growth of iron-related bacteria around the well screen. Mn is oxidized from MnII to MnIV almost exclusively by microbial action (see following) in potable groundwater, as the necessary oxidative redox potential is seldom encountered in such water.

Acidic groundwater (pH less than 7.0) may dissolve calcium carbonate from the formation materials (to create calcium bicarbonate), causing the calcium ions to become dissolved and migrate toward the well screen. High dissolved solids can also create color and turbidity in the water. The reduced pressure in the well and gravel pack caused by pumping, causes precipitation and scaling of calcium carbonate and may encourage iron and manganese precipitation as well.

Corrosion

Three general types of abiotic corrosion (microbially induced corrosion is discussed in the following section) involved in water wells are hydraulic, electro-chemical, and oxygen-cell. Hydraulic corrosion is caused by turbulent flow, hard particulates, or wearing flow velocities, which abrade well components. Hydraulic corrosion is generally due to particulate matter from incomplete well development, or fine material within the formation that is not screened out. Corrosion enlarges screen slots or open holes in the casing or pump column pipe, which allows even larger particles into the casing, and the deterioration accelerates. In time, the casing material reduces, and potentially collapses. Cavitation caused by turbulent flow will aggravate corrosion by flaking off pieces of metal. Pumping at rates higher than screen design flow is the primary cause of hydraulic corrosion in wells.

Electro-chemical corrosion is the dissolution of metal, typically zinc or iron, into solution through carbonation or oxidation reduction reactions. Electro-chemical corrosion is more of a problem in older wells because of materials used in the past. Chloride ions that

exist in raw water can form weak acids that attack metals. Sulfide ions also create acids in certain environments that may attack metal surfaces.

Oxygen concentration (oxygen-cell) corrosion is the most common abiotic mechanism in groundwater wells. Oxidation and reduction reactions occur in groundwater environments and cause electron gradients between areas of relatively higher and lower oxygen. These can accelerate corrosion in a well initiated by some other mechanism. Although galvanic corrosion does occur in fresh groundwater, it is rare and low in intensity compared to that occurring in sea water. Most corrosion of bi-metallic connections described as *galvanic* is also attributable to oxygen-cell gradients. The presence of highly dissolved oxygen may accelerate desiccation of brass or other pipe.

Galvanic corrosion is caused by the generation of electric currents in dissimilar metals. Galvanic corrosion is often a problem with stainless steel pumps that are connected to steel column pipes with bronze centralizers in a steel casing. Newer technologies and the use of fiberglass, bronze, and plastics have reduced galvanic corrosion. The higher the conductance that exists between two metals, however, the greater the potential for galvanic action. This corrosion is typically found where casing screen is joined, where the submersible pumps are joined to the column pipes, or where bronze spiders exist. Poor pump alignment, stressed threadings, or poor welds may encourage this type of corrosion.

Of increasing concern is the feedback of electrical currents from high-voltage power lines on water wells. These power lines create induced voltage on an underground pipe distribution system via the ground. This activity may be intermittent in effect. Because of soil resistance conditions, the effect may only be apparent during drought conditions and progressive damage may develop over several years. It may be necessary to electrically isolate the pump from the distribution system and install a sacrificial anode or automatic electrical compensating device on the system.

Reducing Physical Causes

Proper design will reduce potential excessive entrance velocities or improper screen placement that can allow fine-grained formations to migrate into the wells. Proper materials such as plastics or fiberglass instead of steel or stainless steel should be used in many situations. Dissimilar metals should not be used in close proximity. Improper construction, poor grouting, excessive screen or casing damage, or the removal of protective sealants can lead to physical deterioration of the well. The improper application of certain chemical reagents, especially chlorine, and sequestering reagents, or those used during redevelopment, may exacerbate deterioration. Finally, overly aggressive pumping for redevelopment, over-pumping of the system, or the improper use of surging, may cause structural damage to the well in the long term.

SAND PUMPING

Amounts of sand as little as 0.3 ft³/mil gal of water can cause many operational problems. In addition to causing excessive wear in pumps and valves, control orifices can become plugged, water meters stopped, and sprinkler heads clogged.

In a few rare instances, sand pumping cannot be eliminated, even if a well is properly designed and constructed. Reduced pumping rate by increasing head through valving may give some relief. Where water is discharged from the well into a large tank or reservoir, the sand may settle out and should not cause excessive problems, except for pump and valve wear.

If sand pumping cannot be entirely eliminated, a centrifugal sand separator, as shown in Figure 7-2, may be used. Water enters the body of the device at a tangent immediately

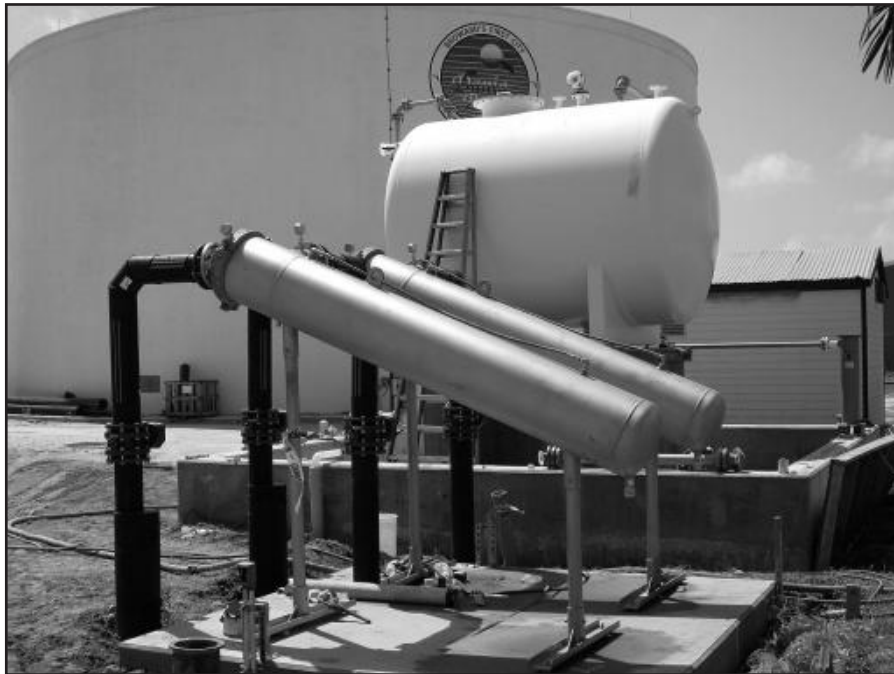

Figure 7-2 Lakos sand separator

below the baffle. The small radius and high velocity create a large centrifugal acceleration, which throws the sand to the side of the device. The sand falls down the side and is collected in the centrifuge tube, while the sand-free water flows out through the hole in the center of the baffle.

The flow is maintained at a constant rate, independent of the inlet pressure, with a flow control valve rated at 0.5 gpm (2 L/min). This patented flow control valve uses a rubber orifice that contracts with increasing inlet pressure. The valve is designed for a pressure variation from 15 to 150 psi (100 to 1,000 kPa).

At suitable intervals, the volume of sand collected is recorded, together with the number of hours of operation. From these data, the average sand concentration may be computed, because the flow through the tester is known. Any significant increase in sand production is noted immediately, and corrective action can be taken before appreciable quantities of sand have entered the distribution system. One tester for each well suspected of producing excessive sand can be provided if economically feasible.

Sand flow into a well occurs only during turbulent flow unrestrained by the gravel pack or screen. Shifting the position of the pump suction, pipe or intake, or installing a suction flow control device (e.g., Aquastream devices) between the screen and pump intake may be more cost-effective than a sand separator device.

MICROBIOLOGICAL FOULING

Microbiological fouling is generally interrelated with physical and chemical processes. Microorganisms can incrust or corrode the system, enhancing physical and chemical deterioration. All well deterioration problems involve some microbiological fouling. The typical symptoms of microbiological fouling problems are

- a decrease in the water quality

- increased drawdowns
- reduced specific capacity
- a change in the amount of iron or manganese in the water supply
- an apparent increase in microbiological densities such as an observance of slimes or staining from the raw water

Microbiological fouling encourages changes in the electrical potential and pattern of the well surface by creating anodes on metallic surfaces to transfer ions. Biofilms are formed that eventually clog screens. The bacteria absorb nutrients and minerals such as iron, manganese, arsenic, nitrogen, and oxygen within the biofilm matrix, leading to the formation of tubercles and films that reduce capacity of the pumps and casings. Wells with water-lubricated vertical turbine pumps are subject to severe microbial action.

Aquifers are ideal environments for many microflora adapted for these conditions. There is tremendous surface area for colonization, the temperatures are relatively constant and moderate, the flow of water provides a consistent nutrient supply, and, except for the immediate pumping zone, the water is not disturbed. The cycling of a pump on and off with the exchange of atmospheric air in the casing provides the oxygen supply to maintain low aerobic conditions sufficient to maintain growth of certain bacteria in the well. All spaces within the formation are potential areas for colonization. Vugular formations (rock with air pockets) or those with significant fracture surfaces are ideal for creating large biofilms within the aquifer, but never indicate severe plugging because of the size of the organisms in comparison to the opening aperture size.

A biofilm is an entire active ecosystem, providing an environment for survival to a variety of microorganisms by storing and transporting nutrients. The biofilm protects the bacteria cells from external reagents such as chlorine, but traps iron, sulfur, manganese, and other nutrients. Precipitates of the iron, sulfur, arsenic, and manganese occur within the biofilm.

The most commonly described bacteria are often referred to as *iron bacteria* (an archaic term for *neutrophilic iron-oxidizing bacteria*) which tend to precipitate iron and create a characteristically colored slime—generally rust colored. They precipitate iron, which can create iron oxide tubercles, and remove iron from groundwater and the casing surface in other areas. Variations include manganese and sulfur-depositing bacteria. Functionally related bacteria (manganese oxidizing bacteria), often of the same general groupings within the proteobacteria, are the primary (possibly sole) cause of Mn precipitation in aquifers and wells. Sulfur-depositing bacteria include a wide range of filamentous and nonfilamentous bacterial types. Sulfur-reducing bacteria (SRB) reduce sulfates or elemental sulfur to sulfides by respiration. The mineralization of iron and sulfur (forming FeII sulfides) caused by SRB with low redox conditions will cause a slime matrix that is generally black in color that may consolidate into hard clogging deposits. Eventually these minerals crystallize as pyrite. As is the case in the sulfur cycle, Fe- and Mn-reducing microflora serve to reduce FeIII to FeII and MnIV to MnII, which can become soluble again. These microflora interrelate in intersecting geochemical cycles. Besides these minerals, nitrogen, arsenic, uranium, gold and other important minerals are subject to biogeochemical cycling. Ehrlich and Newman (2009) provide a comprehensive discussion of microbiologically mediated geochemical cycles common in the environment.

Slime-forming bacteria come in many varieties. They can live symbiotically with other bacteria by providing a protective slime coating. One of the more common genera of the slime-formers is the *Pseudomonas* and related types of gram-negative proteobacteria, some of which are opportunistic pathogens. Sulfur oxygenating bacteria form light-colored filamentous slime biofilms where sulfides are present in groundwater. One genus

is *Thiothrix*. As they grow, these biofilms may form filaments that serve to reinforce the biofilm and protect the underlying bacteria.

When a biofouling problem has begun, little can be done to remove it permanently. Preventing consolidation of biofilm formation and accumulation of deposits is the best strategy and the sooner biofouling is detected, the sooner treatment can begin. Methodologies to detect and manage biofouling through maintenance have improved significantly in recent years and are described in a variety of available literature, notably Smith and Comeskey (2009).

Several steps should be followed to look for bacteria. A down-hole camera should be used to look for the visible signs of biofilm deposits. Any equipment that is pulled out of the wells can be examined and sampled for analysis, and then should be thoroughly cleaned so other wells are not contaminated.

Biofouling can be detected early via indicators of increased bioaccumulation. Since the early 1990s, relatively effective and simple-to-use field tests of biological activity have been developed. Among those available are cultural enrichment methods, including the widely used *biological activity reaction test* (BART) developed by Droycon Bioconcepts Inc. (Regina, Saskatchewan) and a similar method developed independently by practitioners in Argentina at Laboratorio Microbiologia Industrial, La Plata (MAG). Their theory and use are summarized in Cullimore (2008) and Gariboglio and Smith (1993), respectively. Evaluations of BART methods and comparison to other culturing methods by independent users are available (Smith 1992; SWWI 2000). BART and MAG tests are now included in *Standard Methods* (Section 9240, from the 22nd edition). These tests are type-specific (tests detect particular functions such as sulfate reduction) and require the collection of a water sample and exposure to the media used in the test. If present in the sample, the organisms will grow.

Culturing methods such as BART or MAG tests (or other cultural methods described in Section 9240) are limited to use in detecting bacteria that can be cultured (a minority of those present) and do not permit a direct observation of biofilm properties. Microscopy (which has its own limitations) provides the capacity for direct observation of biofilms. This is best conducted using relatively intact biofilm examples. For this reason, biofilm collection methods have been developed to aid in providing high-quality biofilm samples. Borch et al. (1993), Smith (1992), and Smith and Comeskey (2009), as well as Section 9240, describe many of these.

Collectively, these tests (plus some others) permit a qualitative-to-semiquantitative evaluation of the microbial ecology of wells and water systems that is useful in planning rehabilitation and maintenance. Experience in their use for this purpose is evolving rapidly. Proper sampling and systematic application are essential (Smith 1992; Smith 1996; Cullimore 2008; Smith and Comeskey 2009).

If BART shows bacteria are present, a microbiological lab capable of identifying bacterial and fungal species may be consulted. Another analytical step that may be employed in understanding the conditions of an aquifer or well field zone is to employ biochemical methods that can provide a rapid and more comprehensive inventory of microbial types present in BART or MAG testing. If conducted systematically, these biochemical methods can provide a maintenance condition indication to guide the scheduling of testing (Cullimore 2008; Smith and Comeskey 2009). Such monitoring programs should be initiated under the guidance of an environmental microbiologist familiar with these methods. Repeat samples are beneficial as they indicate the changes that may be occurring in the formation. A common but unrecognized benefit of the test for coliform bacteria is that it can reveal additional bacterial strains—they are the pink dots that grow on the filter test media that are not coliforms.

TREATMENT OF FOULING PROBLEMS

Many older wells were installed with methods no longer currently in use and do not meet current standards. In these cases, some work can be done, but the problems may not be fully corrected. For many older wells, acidification, typically using hydrochloric acid, can improve performance. Hydrochloric acid solution will remove or loosen incrustation in the screens or the column pipe, although it will not remove much biofouling, and it can cause screen failure in older wells, especially if repeatedly treated.

Physical agitation or surging (redevelopment) is necessary to remove dislodged deposits during well treatments. At times redevelopment may be used alone to remove incrustation or reduce fine material entering the well screen or gravel pack. Methods used are essentially identical to those used for original well development and are described in detail in Driscoll (1986), Roscoe Moss (1990), Borch et al. (1993), Smith and Comeskey (2009) and other references on well construction and rehabilitation.

In cable-tool surging, tools are used that push water down into the well and pull it out, just as old hand-pump well systems worked. Initially, the surge device is operated at less than three strokes per minute at 6 in. to 10 in. per stroke. Over time, the frequency and the stroke should be increased (up to about 2 ft/sec over a 3-ft stroke), which increases the surging. If the casing or the formation is weak, or the screens damaged, the well structure can collapse during surging.

Other redevelopment methods include various kinds of jetting and gas-percussion methods, and carbon dioxide (CO₂) injection.

Chemicals are commonly added to the well to enhance the effectiveness of redevelopment. Chemical choices for rehabilitation and maintenance cleaning depend on the clogging problem and the water quality, and may differ in type and concentration depending on whether rehabilitation or maintenance is the objective. For example, chlorine is used as a biocide for sanitation. In the past, chlorine was widely specified for control of microbiological fouling, although in most cases it does not kill all the bacteria; it only serves to control the biofilm. Recent experience indicates that chlorine only “caramelizes” the biofilm and may actually aid biofilm microbial survival. For sanitation, a 12 percent sodium hypochlorite solution (preferred over calcium hypochlorite unless pH and alkalinity are low) provides the chemical strength needed to control the bacteria. In some cases, hydrogen peroxide may be used to address mild slimy biofouling problems, but certain bacteria (e.g., *Pseudomonas* species) may be able to use the oxygen to their benefit, increasing biological activity. There is a major revolution in the practice of well chlorination in recent years, concisely described in Schneiders (2003) and Smith and Comeskey (2009).

Another option is acidification, which may drop the well bore pH to less than 2. Hydrochloric, sulfamic, acetic, glycolic, phosphoric, or nitric acid are used, but these chemicals must be used with very deliberate care. Deterioration of the well materials must be weighed against the removal of the biofilm or the incrustation. Hydrochloric acid (HCl) use should be confined to solution enhancement of limestone rock. In many cases, solid sulfamic-based acids can replace HCl use more safely. If biofouling removal is the objective, a solution of 10 to 15 percent acetic acid or 5 to 10 percent glycolic acid, amended with sulfamic acid to achieve a pH of 2, is commonly used, often with dispersant-wetting agents. This type of solution attacks biofilm integrity without the aggressiveness of hydrochloric, nitric, or phosphoric acid solutions. Phosphoric acid is sometimes recommended for this purpose (e.g., Schneiders 2003; Sterrett 2007) but strongly contested based on other experience (e.g., Smith and Comeskey 2009). The addition of phosphates has been used, as it makes water “more slippery” and increases total well capability. However, the phosphates *may* provide a scarce nutrient for biofilm, and alternative chemicals that do not contain phosphates are now widely available. The problem with phosphoric acid, which has

many good deposit-removal properties, is the possibility of oxidation of phosphoric acid to phosphate by groundwater microflora and subsequent growth promotion. Guidance in chemical choice is supplied in Smith and Comeskey (2009) and other publications, as well as on Web sites such as Ground Water Science. In all cases with chemical use, a plan for handling hazardous material and disposing must be made. None of these chemicals should be discharged in an uncontrolled way to the ground; they must be hauled to an approved disposal site, such as a sanitary sewer.

Commercial blends of chemicals have become available, and often have the advantage of being listed by NSF International and meeting the requirements of many jurisdictions for chemicals used in contact with potable water. These blends often have improved properties and provide the advantage of simple, detailed instructions and improved availability.

Heating chemicals greatly increases their activity, which is valuable in cool groundwater, and increases penetration of chemicals into the formation. Less concentrated solutions can be used. Additionally, heat aids in shocking and disrupting biofilms and aiding in their removal. Heat-amended chemical treatments with redevelopment are among the *best* documented of more recent treatments. Two related processes, blended chemical heat treatment (BCHT™, developed by ARCC Inc., Fort Orange, Fla., and still provided by limited contractors) and the ultra acid base process developed in Canada (SWWI 2000), represent the most systematic application of mixed methods involving heat.

Another method, CO₂ injection, uses gaseous CO₂ and liquid CO₂ under 100 psi of pressure. This technique causes the CO₂ to enter the formation, dropping the pH through a conversion of the CO₂ to carbonic acid. If liquid CO₂ is used, the water freezes in the formation, causing cracking and loosening incrustation. The formation may also crack and loosen, which can free the fractured zones or crack the bedrock formations and potentially increase yield. After the CO₂ is injected, the well is surged and redeveloped. A chemical treatment and development step is frequently used in addition to the CO₂ treatment. This method is not especially effective on biofilms. The most complete independent description of the use of this technique is found in Lennox (2007).

Sonar jetting and other gas-charge percussive techniques involve deploying a sequence of small blasting caps suspended in the screen or exposed borehole and set off, sending shock waves and gas through the screen and into the formation. The goal is to blast incrustations off of the well screen, formation, and casing. After sonar jetting, surging and full redevelopment of the well must occur to remove all of the excess debris. Acidification improves the process to some extent. Potential problems with this process may be the inability to get permits to do the blasting and the potential damage that may occur to the casing or the screens. An example case history of combined sonar jet and chemical treatment use is found in Ground Water Science (2000), and it is described in Smith and Comeskey (2009).

Based on experience with terrestrial seismic borehole surveying, the process was tried as a well rehabilitation process by employing air or gas-powered signal guns, in which experts noticed that they loosen deposits in the boreholes. ARCC Inc. and the University of Mississippi experimented with it in the early to mid-1990s in the United States, and groups in Germany, Israel, and the United States developed variations on the technique in the same time frame.

In each case, pressure pulse sequences are created by pulsing inputs of gas or water portions under high pressure using a pulse generator that is inserted in the well attached to the pressure hose. The pulse generator is provided with a valve system that is able to rapidly release the energy that is accumulated in the generator in the form of highly compressed gas (or in the case of the hydropuls tool in certain cases, water) within a very short time (milliseconds). The fluid vents from the tool (air displacement of about 1 m in

1 millisecond). This action creates hydraulic shock waves moving outward, and then a cavitation and negative-pressure effect is caused as the expanding bubble collapses suddenly. The alternating effect of the pressure load and the pressure relief loosens fines, encrustation, etc. on the screen, borehole face, and in filter pack. The return flow transports loosened material into the well, where it can be pumped off. These have proven to be effective and repeatable redevelopment tools. They are further described in Smith and Comeskey (2009) and on the Ground Water Science website.

A newly devised variation on the common jetting tool has been developed that jets at very high pressure (up to 20,000 psi) but rapidly and randomly rotated. These have demonstrated effectiveness in rapidly removing hardened solids and residual mud and drilling damage around well screens, even at great depth.

Other methods that show some promise in certain specific cases are suction flow control devices and inner sleeve installations within the casing using entrained air to reduce fouling.

Environmental Issues

Any of these methods creates potential environmental problems that must be addressed by appropriate regulatory agencies. All unplugging and cleaning methods require the discharge of water, which can contain chemicals, silt, sand, and other debris. The quality of this water may require treatment. A common method of disposal is to discharge the well volume into a tanker truck, stabilize the chemicals, and haul the debris to a wastewater treatment plant. The wastewater plant personnel will not appreciate large volumes of well debris in the discharge, so some screening would be beneficial. The liquid may be hauled to a landfill in some jurisdictions. Appropriate regulatory agencies should be consulted and necessary permits obtained.

Ideally, minimizing the impact of treatment methods should be a part of the planning process. Actual chemical risk can be minimized by choice of chemical, using the minimum possible aggressive chemical concentration (relying more on development action and increasing effectiveness using heat), and handling and discharge risks are manageable with proper planning. Much can be accomplished by intelligent neutralization, containment, and volume reduction at the well treatment site. Note that well chemicals must *never* be neutralized in the well water column itself, as this negates all positive effects of the well cleaning process.

In each case, the waste stream characteristics must be identified, including

- pH of the water
- chloride level
- toxic substances
- silt
- the quantity of the water to be discharged
- the time element for which the discharge will occur (i.e., a relatively consistent flow over a period of time or surges)
- the new water quality of the wells
- the uptake of metals, SOCs or VOCs that might violate air or water standards

Regulatory agencies that may be involved in any discharge to surface waters or wetlands may include national, state, and provincial, or regional agencies, and local agencies, especially for discharges to sanitary sewer systems.

ECONOMICS OF CLEANING PLUGGED WELLS

Cleaning a plugged well can help maximize the return on a capital investment in a well. Operation costs can be reduced by eliminating pumping inefficiencies and restoring the well efficiency to its previous level. To properly evaluate the economics of cleaning plugged wells, historical records are needed for flow, test data, specific capacity calculations, development records, design details, pump performance curves, and some periodic information on inspections. This data will create a baseline to compare all future well performance calculations. The information may also be of use in selecting proper methods for unplugging the wells. Routine monitoring should include flows, drawdowns, hours pumped, power usage, and calculated specific capacities, all of which should be plotted for each well.

To evaluate the costs, the initial costs of service should be determined using the current pump and well performance. Changes in specific capacity will affect both the power and the hours pumped. The assessment over time indicates what the changes in the efficiency of the pump have been. Record keeping will tell operators and engineers when the well has deteriorated to a point that it needs to be rehabilitated. The industry standard is a 15 percent loss in specific capacity.

It is helpful to conduct a cost-benefit (C/B) analysis for the proposed action. The tendency is to oversimplify this exercise, which may underestimate the benefits (B) of maintaining efficient well performance. For one, calculating the actual value of produced water is necessary to calculate a B to compare to treatment C. In a municipal setting, that B is salable water. C/B analyses are best evaluated in terms of cost per unit water (e.g., \$ per cubic meter or 1,000 gal), and value is best evaluated in terms of life-cycle cost. A more detailed discussion of this exercise and concepts is found in Smith and Comeskey (2009) and based on Helweg et al. (1983). The price and availability of land has become an increasingly important factor in North America. In the “frontier” mentality prevalent through the 20th century, it is often assumed that open land can be acquired at reasonable cost to develop new well fields to replace the old. In recent years, such land has become increasingly unavailable at any price. Thus, existing productive wells may actually become functionally priceless.

The risks involved with well age must be compared with the cost to rehabilitate, the well’s life expectancy, and the potential for gains in specific capacity to determine whether to rehabilitate the well. A well that has been rehabilitated many times and shows a general decline in performance and an inability to regain the initial specific capacity may be a candidate for abandonment (see Figure 7-3), although a change in treatment method may reverse the trend. Any evaluation should include the cost to rehabilitate or to replace the well if the cleaning process is not successful, the value of additional water obtained, and comparison of the cost per unit of water pumped between treatment and other alternatives such as well replacement. Replacement wells have the added issue of dealing with relocation of pumping, which may entail added property acquisition, and in some areas, water rights. Table 7-1 is an example of how the replacement versus rehabilitation options must be weighed.

When the current costs are developed and compared to the initial costs, and the risks are determined, a direct comparison of the current versus initial costs can be made. This comparison will indicate the change in operating costs due to inefficiencies of the well. For a specific capacity decline of more than 15 percent, some rehabilitation should take place, as the increase in operational costs will be high. In most cases, there is a relatively short payback period between the costs of rehabilitating the well and the cost for installation of a new well. In cases when the wells are relatively old, the replacement cost should be used to determine payback period. For old wells where performance continues to decline, new technologies can provide substantial benefits. The following section is a series of calculations that have been made as an example.

Table 7-1 Well rehab versus replacement comparison

Well Rehabilitation	Replacement Wells
–Cost: \$20,000	–Exploration for a well
–Payback in Water	–Permit application
–Will break even: 1.8 years	–Water rights acquisition
	–Design engineering
	–Land acquisition
	–Pipeline design
	–Treatment changes
	–Cost: \$300,000

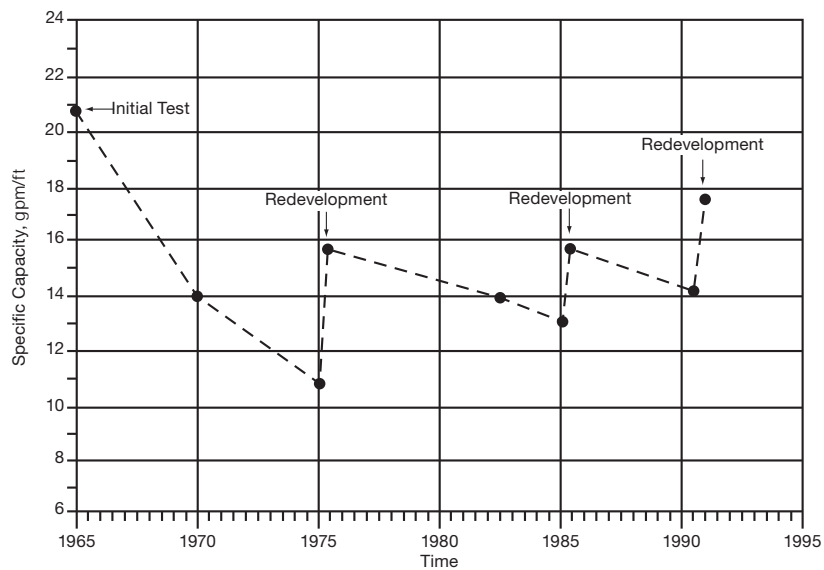

Figure 7-3 Well efficiency monitoring, Catamount well field, well No. 54

Calculation

This analysis was originally presented at the American Water Works Association Annual Conference in Toronto, Ont., on June 22, 1996, by Kenneth C. Gaynor with Hydro Group, Inc.

Example Well for Cost–Benefit Analysis

Original well performance

Static water level, SWL:	15 ft
Well depth:	85 ft
Available drawdown:	40 ft
Flow rate, Q:	700 gpm
Pumping level:	48 ft
Drawdown, s:	33 ft
Specific capacity, Q/s:	21 gpm/ft
TDH (s + SWL + h _p)	15 + 33 + 120 ft (pressure head, h _p) of total dynamic head

Annual Operating Conditions

The volume of water pumped is 157 million gallons. Operational time is 3,738 hours per year. Average kilowatt cost is 9 cents per kilowatt.

Calculation

Original Annual Operating Cost of Example Well

$$\begin{aligned} \$/\text{hr} &= \frac{Q \times \text{TDH} \times 0.746 \times \$/\text{kW}\cdot\text{h}}{3,960 \times \text{pump eff.} \times \text{motor eff.}} \\ &= \frac{700 \times 168 \times 0.746 \times \$0.09}{3,960 \times 0.82 \times 0.90} = \frac{7,895.6}{2,922.5} = \$2.70/\text{hr} \end{aligned}$$

To get the cost per year, multiply by the hours:

$$\begin{aligned} &= \$2.70/\text{hr} \times 3,738 \text{ hr/yr} \\ &= \$10,093/\text{yr} \end{aligned}$$

Example: Well Performance History

Well performance history is shown in Figure 7-4.

Current Situation

- Specific capacity decreased to 7.5 gpm/ft
- Maximum available drawdown well (s): 40 ft, in effect, the actual drawdown
- Maximum yield from wells: 300 gpm
- Curve efficiency of 300 gpm: 60 percent
- Pressure head, combined lower pumping pressure head + valving back pressure (h_p): 143 ft
- TDH ($s + \text{SWL} + h_p$) = (40 + 15 + 143) ft = 198 ft of total dynamic head

NOTE: The current impaired situation is that the well is producing 300 gpm using the total available drawdown (40 ft) and thus $Q/s = 7.5$ gpm/ft at 300 gpm. Remember that for Q/s values to be comparable, they have to be Q/s for comparable Q (flow rate). That is, the $Q/s = 21$ gpm/ft at 700 gpm in the original is not the same as 7.5 gpm/ft if $Q = 300$. In this condition, the well probably could not be tested at 700 gpm. For this well pump, rated to pump 700 gpm versus the as-built TDH, they would be valving it back to 300 gpm, thus adding to pressure head (h_p), and that would account for the 198 ft TDH ($15 + 40 + h_p = 143$) = 198. The h_p would be a combination of lower pumping pressure head + significant imposed valving back pressure.

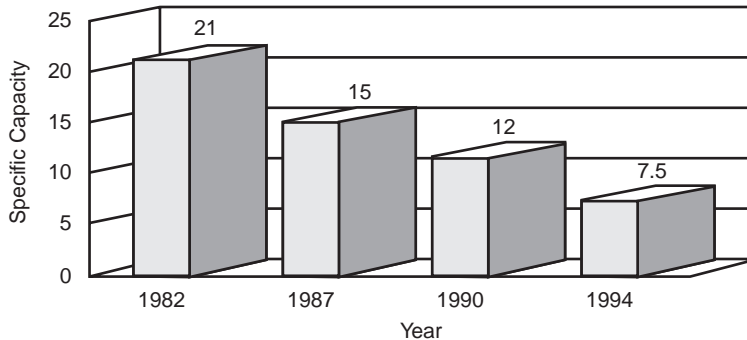

Figure 7-4 Example of well performance history

Operating Costs of Inefficient Well

$$\begin{aligned} \$/\text{hr} &= \frac{Q \times \text{TDH} \times 0.746 \times \$/\text{kW}\cdot\text{h}}{3,960 \times \text{pump eff.} \times \text{motor eff.}} \\ &= \frac{300 \times 198 \times 0.746 \times \$0.09}{3,960 \times 0.60 \times 0.90} = \frac{3,988}{2,138} \\ &= \$1.86/\text{hr} \end{aligned}$$

Current Costs

Given usage of 157 million gallons per year and to have 300 gpm, the pump must operate 8,722 hours, which is \$16,223 per year.

Potential Savings

Current well cost:	\$16,223
Original cost:	<u>– \$10,093</u>
Savings per year:	\$ 6,130

Comparison to Cost of Redevelopment—Conclusions

The cost of redevelopment is \$10,000; the payback is 1.63 years. The economic decision is to rehabilitate the well and repeat the redevelopment.

Another way to look at this cost comparison is to invest in methods to slow or halt performance decline. The well rehabilitation effort necessary to return the well to its as-built condition from 7.5 gpm/ft at 300 gpm is likely to be more than \$10,000 in current dollars, or the rehabilitation planned would have a short effectiveness life and would need to be repeated.

CASE STUDIES

In most well plugging situations, no single factor is involved with the well plugging or corrosion problem. As a result, no clear-cut methodology can identify and clear well field problems. Two of the following examples are from Florida; one system is a fresh, surficial aquifer zone, the other a deeper, brackish aquifer. Both have severe microbiological problems.

Collier County Well Field

The Collier County Water–Sewer District is located in southwest Florida surrounding the city of Naples. The service area is approximately 200 mi². The system has been developed since 1982 when the first well field was established.

The primary drinking water supply is from the surficial Tamiami Aquifer. Below the Tamiami Aquifer is the Lower Tamiami Aquifer, which yields higher quality water for treatment. While in some areas of Collier County there is little differentiation between these aquifers, at the district's well field between 30 ft and 50 ft of fairly tight clay and dolomite separate the two, limiting vertical recharge. This formation is highly transmissive and is primarily made up of highly fractured and solutioned limestone. Recharge is primarily via rainfall, although a significant portion of the recharge may come laterally from the Big Cypress and Corkscrew swamp areas. The overlying area consists of low-density residential development (a minimum of 2.5 acres per household) and some minor incidental commercial development. Recharge capability is high. Below this formation is a series of

progressively more saline aquifers starting with the Hawthorn Group at 180 ft below sea level.

In investigating potential well water supplies for the district, Collier County selected the Lower Tamiami Aquifer to provide the water, which is a highly transmissive production zone of vugular limestone. While recharges are primarily from rainfall, some organics are brought in from the adjacent swampy areas. The production zone is between 60 ft and 140 ft below sea level and each well is designed for 1 to 1.5 mgd. Since the initial well field construction, two expansions have been completed. Except for the first five wells, all of the wells are constructed with polyvinyl chloride (PVC) casings.

In 1990, the district designed a 12-mgd membrane softening (nanofiltration) facility located five miles north of its lime softening plant. The two plants manifold together and use the same well field for water supply.

Just before the design of the membrane softening plant, the district found several of its new 304 stainless steel column pipes had been sheared off only 18 months after installation. When fished out, the column pipes showed a black slime ringing the column pipe at the point of shearing. At the same time, a significant amount of slime was noted coming into the lime softening plant's degasifier towers. Specific capacity of the wells was analyzed and found to be significantly reduced from their initial rates. The steel column pipes and other steel within the pumps and the facility showed a significant amount of corrosion. The typical corrosion was pitting, with black longitudinal slime running with the vertical direction of the column pipe (see Figure 7-5). Analysis was taken of the slime and sent to Harco Technologies in Atlanta and Layne-Atlantic in Kansas City. Reports from these two companies indicated that there was a significant and widespread pitting of the column wall thicknesses, including some portions where 75 percent of the column pipe's thickness had been lost. Bacteria consisting of *Gallionella* and other iron bacteria propagated on the stainless steel materials, and anaerobic SRB had developed a symbiotic relationship with the aerobic iron bacteria. Various slime-forming bacteria of the *Pseudomonas* genus had interjected themselves into the symbiotic relationship by providing an overlying slime layer to protect the iron and SRB. Because the buildup creates an anode on a pipe, it exacerbates the deterioration of the ferrous material. Unfortunately, these species are persistent, especially the pseudomonads, which can attach colonies to stainless steel in a matter of hours. Once attached, the colonies are extraordinarily difficult to eliminate, therefore the best strategy is to control the colonies through treatment at the wells.

The bacterial counts were found to be relatively high and required some form of treatment. Further analysis indicated that the lime softening process, because of the mixing that occurred and the "sticky" constituency of the bacteria, did a relatively good job at removing it. However, the proposed membrane softening process would not be as effective in this removal. The bacteria would foul the proposed membranes in the plant and could lead to breaching and lower plant efficiencies. Further review indicated the corrosion of the steel pipe at the lime softening plant could also be partially accounted for as a result of the bacteria being brought in with the raw water.

To address this situation, the district proceeded with bids to initiate a routine disinfection program that added 2,000 to 6,000 parts per million (ppm) of calcium hypochlorite on a monthly basis. In addition, all ferrous material was removed from the wells, polyvinyl chloride (PVC) slip lining was installed in the five original steel casings (with a loss of capacity), and a new composite column pipe installed. All pumps were changed to bronze construction. These pumps were not only less costly, but faster to get and more resistant to microbiological attack than the stainless steel pumps. All new wells were installed with PVC casings, bronze pumps, and a composite column pipe called Wellmaster®.

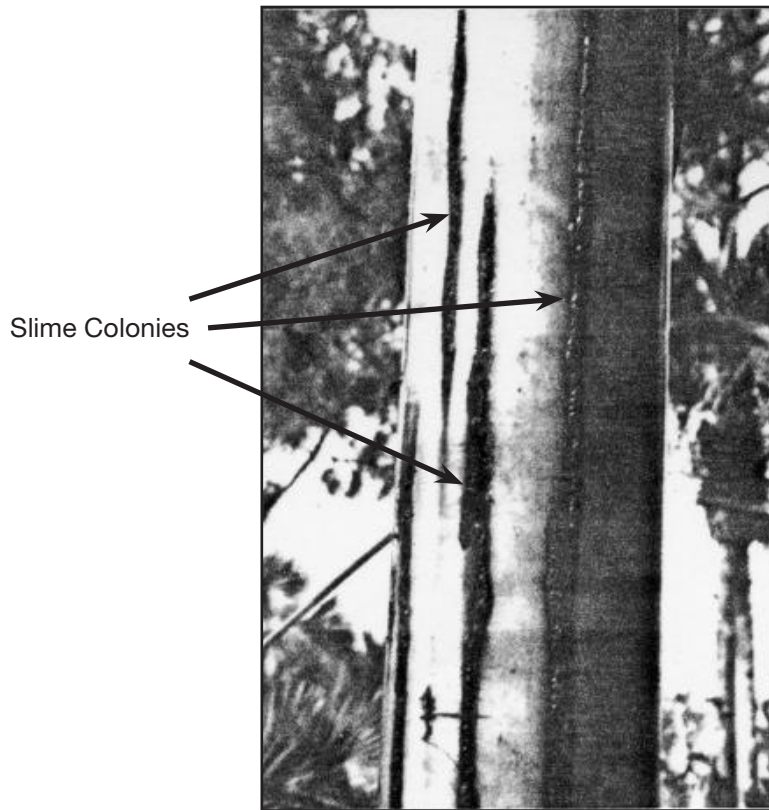

Figure 7-5 Example of corroded column pipe

The district monitored the total bacterial count changes and found that despite initial counts in excess of 10,000 colony-forming units (cfu)/100 mL, with monthly disinfections, the counts began to decline relatively quickly. However, any prolonged time between disinfections or lowering the water table caused the bacterial counts to climb again. A side effect the district noted was that some well materials deteriorated during the disinfection program, including the composite Wellmaster pipes. The column pipes were removed from the wells each time they were chlorinated to address the deterioration of the column pipe.

Near the end of the construction of the membrane water treatment plant, the disinfection program lapsed when the contract ended. During plant startup, a significant quantity of the bacteria did get into the membrane units, requiring extensive cleaning of the membranes with bisulfite, citric acid, and hydrogen peroxide to eliminate the growth and restore the membrane efficiency. The extent of cleaning that was performed on these membranes is not desirable in a new membrane facility where the membranes are expected to have a life of five to seven years and the facility is expected to have a life in excess of 30 years.

A second plugging problem occurred in well No. 12. Symptoms included a significant loss of specific capacity, inability to pump the required amounts, and inability to remove the pump. A television camera was dropped down the well. Significant quantities of iron, sulfur-reducing, and *Pseudomonas* bacteria were noted on the walls of the casing pipe. When the camera reached the pump, the casing appeared to have collapsed into the shape of a figure eight. The pump was below this collapsed point and could not be withdrawn.

Analysis of the problem indicated that the reduction of well capacity (due in part to the bacteria) and lower aquifer levels caused by drought in 1990 and 1991 caused the

drawdown to reach a point just a few feet above the top of the pump. Because submersible pumps are designed to have several feet of water above them to keep them cool, when the water dropped to this point, the pumps heated enough to cause the PVC casing to buckle.

As a result of this analysis, all the submersible pumps were lowered 10 ft to 20 ft (depending on the well). The pump in well No. 12 was cut loose and the possibility of cutting out the collapsed section of the pipe and splicing in a new one was considered. However, because of the cost for the splicing and the resulting loss of capacity, the well was abandoned.

The Collier County Water Sewer District's experience indicates that bacterial fouling can lead to column pipe damage, membrane fouling, collapsed casings, and lower pumping capabilities.

City of Venice Well Field

The city of Venice is located in Sarasota County, 40 miles south of Tampa, Fla. As a coastal community, the city has relatively little fresh water available. The overlying formation is undifferentiated sand and clay formation that lacks the ability to provide significant quantities of water. As a result, the city of Venice used the next aquifer formation, the Lower Hawthorn.

The production zone for the city of Venice is located between 200 ft to 320 ft below sea level. Each well produces 1 mgd, and the wells vary from 5 to 21 years old. The raw water, while slightly brackish, has little color and hydrogen sulfide, and as a result, lends itself to treatment with low-pressure reverse osmosis (RO).

The city has a 4.0-mgd low-pressure RO plant to treat the brackish Hawthorn water. Typically, low-pressure reverse osmosis systems have a 70 percent recovery rate. However, because of high sulfates in the raw water, the city of Venice is able to recover only 50 percent of the raw water as permeate. As a result, nearly 8 mgd is required to produce 4 mgd for the distribution system.

The city experienced problems in a number of its wells, including an increase in drawdown, a decrease in specific capacity, and pipe and pump cavitation. In addition, some sand was found in the prefilters. An increase in sulfates and chlorides was noted and slime began to be produced on stainless steel column pipes in the pumps. A video camera inspection was made in several wells. In one well, at 227 ft below sea level, sand and other materials were entrained in the open hole of the formation. The video indicated that the formation was producing intermittent fine sand and silt that were deleterious to the cartridge filters and the RO membranes. In addition, the wells contained a significant quantity of *Pseudomonas* bacteria species. The bacteria were attacking ferrous materials and causing the formation to plug, resulting in the increased drawdown, pump failures, and lower water quality. The bacteria also have a potential deleterious effect on the reverse osmosis process efficiency.

In response to the analysis, the city instituted a routine disinfection program of 6,000 ppm of chlorine on a monthly basis. Over time, the city staff began to perform the routine disinfection and the timing has decreased to once every 90 days. A program to routinely sample for microbiological parameters was instituted, and a water quality and water level monitoring program was developed. All pumps were changed from stainless steel to bronze.

The sand problem could have been partially caused by the check valves opening and closing on the wells. Slow opening and closing check valves were installed on each well to reduce the sand production. A sand separator was installed before the headworks of the pretreatment plant. The sand separator is a large, Lakos Laval, stainless steel sand separator that mechanically removes sand from the raw water. A sand separator is relatively easy and inexpensive to install.

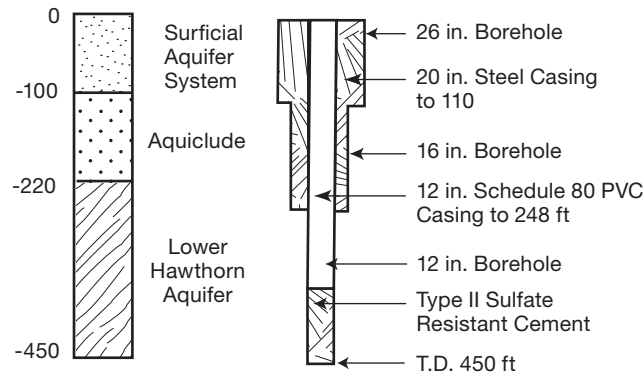

Figure 7-6 Venice RO well construction after rehabilitation

A second well showed similar signs: an increase in drawdown, an increase in bacterial counts, and an increase in total dissolved solids, chlorides, and sulfates. Clogging also occurred. In viewing the well, the production well had become connected with an improperly abandoned well constructed seven years earlier in a deeper saline zone of the Floridan Aquifer. The abandoned Floridan well was contributing poor water quality and bacteria via fissures located in the lower portion of the well.

As a result of the physical log and television survey, the city plugged the lower portion of the well with Type II sulfate-resistant cement between 350 ft and 450 ft, which is depicted in Figure 7-6. The well was then disinfected and a routine monitoring of the bacteria and the chlorides continued. Compilation of information after the plugging showed a steady and continuing decline of the chloride levels from a high of over 2,500 mg/L to about 500 mg/L over the period of just a few weeks.

Conclusions from the Venice well field indicate that microbiological fouling may be a more prevalent problem than anticipated and that more sophisticated treatment methods may be more susceptible to the microbiological fouling than traditional methods. In addition, deeper wells may be severely affected by improperly abandoned wells. A full investigation of such wells must be conducted. The disinfection program restored the capacity of the well field and the plugging of the well to seal off the impacts of the improperly abandoned well did not significantly decrease the well's capacity.

Elkhart, Indiana

The South Well Field, in Elkhart, Ind., one of three operated by the city's Department of Public Works and Utilities (DPWU), is developed in the glacio-fluvial outwash Yellow Creek tributary of the St. Joseph River aquifer. This well field is developed with three high-capacity screened "gravel-wall" wells and supplies a conventional aeration/pressure-filtration water treatment plant. Over time, these wells have experienced performance decline, adversely affecting the economy of the plant and its operations, with periodic attempts to restore production capacity.

Wells in the South Well Field have experienced a decline in performance since at least 1971, when the first rehabilitation was conducted on well No. 1 (the northern-most of three). Each of the wells was treated several times. From the outset, the problem was attributed to "iron bacteria" and treated for such periodically. In its 1998 analysis, a bio-fouling cause was confirmed. A review of the treatment history since 1971 showed that, despite repeated treatments, a pattern of continual decline was evident. However, this decline was reversed somewhat by rehabilitation events. Specific capacity (yield per draw-down) is a readily calculated indicator of hydraulic performance change in wells.

Well No. 1, having the lowest initial specific capacity of the three (35 gpm/ft), declined below the optimal pumping economics point most quickly. Rehabilitation was first attempted six years after completion with no improvement, and then was permitted to decline in performance to uneconomical levels before a series of treatments from 1981 to 1989 kept specific capacity in the mid- to upper 20-gpm/ft range. Treatment effectiveness then fell off rapidly, with specific capacity falling to as low as 2 gpm/ft, despite conducting alternative methods of treatments, until the well was effectively abandoned in 1995. The Table 7-2 summarizes treatments in well No. 1.

Wells No. 2 and No. 3, with higher initial specific capacities (51.2 gpm/ft and 88.6 pm/ft, respectively), appeared to decline in performance more slowly. Well No. 2 was not rehabilitated until 21 years after original construction and specific capacity had fallen to 63 percent of original. Well No. 3 had a similar history but was permitted to drop to <40 percent of original capacity in 14 years.

On both wells No. 2 and No. 3, two rehabilitations each were performed in 1987 to 1991 once problems were recognized by the DPWU water staff. Chemicals used are as indicated. Table 7-3 summarizes the results.

Table 7-2 Timeline for well capacity—well No. 1

Date	Treatment	Before Capacity*	After Capacity
Dec. 1971	Acidization (A-6), phosphate (P-6, B-6), surging	28 [†]	27.90
Sept. 1982	Acidization (A-6), phosphate (P-6, B-6) with HTH, surging [‡]	18.9	26
Sept. 1985	Phosphate (P-6) with HCl acidization and A-6, surging	20	28.3
Dec. 1987	P6 + HTH, light acidization, alternating, surging	26	26
Nov. 1989	Phosphate and acidization, chlorine and wetting agent, phosphate plus wetting agent, surging	20.7	23.7
Oct. 1991	Phosphate with Cl ₂ , wetting agent, acidization alternating, surging	19.1	18.6
Mar. 1992	Surged and caustic soda added	12.5	10.65
1993	Sonar jet treatment	10	7
1995	Aquafreed treatment	2	11

*Capacity = specific capacity (yield Q in gal/min per drawdown s in ft).

[†]Original capacity = 34.6

[‡]Treatments typically included alternating treatment chemical types and surging. Several hundred pounds of chemical typically used.

Table 7-3 Timeline for well capacity—well No. 2 and well No. 3

Well No. 2				
Events	Treatment	Before Capacity	After Capacity	% Original Capacity
1987	Acidization, phosphate, surging	34	44	86
1991	Acidization, phosphate, surging	33	41*	80
Well No. 3				
1987	Acidization, phosphate, surging	34	62.5	71
1991	Acidization, phosphate, surging	48	65.6 [†]	74

*Capacity for 898 gpm.

[†]Capacity for 932 gpm.

For well No. 2, the 1987 treatment restored capacity to 86 percent of original, but capacity declined to below the 1986 precleaning value by 1991. The 1991 treatment restored capacity to 82 percent of original. However, note that the capacity reported was for 898 gpm and not 1,420 gpm. Specific capacity for any well at any point in time declines with increased pumping rate (Driscoll 1986). An estimated capacity for 1,420 gpm at that time would have been less than 25 gpm/ft. Capacity then was permitted to decline precipitously to 23 gpm/ft at 800 gpm prior to cleaning in September 1998.

For well No. 3, the 1987 treatment restored capacity to 71 percent of original, but performance declined to 53 percent of original by 1991. The 1991 treatment restored a reported capacity (for 932 gpm) to 74 percent of original. An estimated capacity for 1,240 gpm at that time would have been something less than 49 gpm/ft. Capacity then was permitted to decline precipitously to <20 gpm/ft at 393 gpm prior to cleaning in September 1998.

Factors in Well Performance Decline in South Well Field

An analysis of the history of treatment performance and well performance decline in these wells shows several contributing factors:

1. The aquifer and well conditions have clogging potential. The working mechanisms are a combination of fine sediment migration from the glacio-fluvial formation (mixed particle sizes) and biofouling. Fine sediment migrates toward the well. Biofouling theoretically forms in a cylindrical band through the depth into the formation where iron oxidizes to the screen face. While biofouling does reduce hydraulic conductivity, it clogs more effectively as it traps in-migrating particles.
2. The wells were permitted to decline in performance below the point where full-performance recovery was possible. Below about 75 to 85 percent of original or target specific capacity, it requires a great amount of development energy to restore performance, and most especially to remove nutrients and residual debris to slow the return to well decline after cleaning.

Unfortunately, Elkhart's well field operations team from the mid-1980s to early 1990s had a well maintenance monitoring and treatment plan in place that could have halted decline earlier. However, this plan was permitted to lapse for several reasons. This kind of intermittent well maintenance history is more the exception than the rule in well field management.

Prior to 1998, phosphate-containing surfactant compounds were used in each treatment in large quantities. These were selected with the best of intentions based on information provided by chemical suppliers and short-term (<10 year) experience in well fields (including Elkhart's) that showed good initial results. However, phosphorus-containing surfactants are suspected of ultimately being counterproductive in well rehabilitation use because of residual phosphate (a limited nutrient in groundwater). Phosphorous is adsorbed to clays by cation exchange and available for bacteria to use in metabolism and cell growth and development (e.g., Borch et al. 1993; Smith and Comeskey 2009; and Layne Inc., internal corporate communication).

A condition commonly observed in sand-and-gravel wells treated repeatedly over time using phosphorus-containing compounds is a change in the type of biofouling present. It is transformed from a low-biomass filamentous form toward a bulkier, slimy type of biomass that is more difficult to remove using conventional rehabilitation methods. This change results in an acceleration of the performance decay in such well fields. The change from short-term success to long-term acceleration of decline seems to be illustrated by the capacity history graph supplied by Peerless Midwest for well No. 1. Successes in the 1980s are followed by rapid declines in performance persisting to the present.

Evidence of a possible change in biofouling in the DPWU South Well Field was provided by a review of color down-hole videos performed on well No. 1. While in the past, the problem was described as *iron bacteria* (filamentous iron-related biofouling), recent videos showed a more gray, flocculent, slimy growth. BART methods (Droycon Bioconcepts) and microscopy (methods per *Standard Methods*; Smith 1992; Smith 1996) confirmed the potential for intense slimy growth. Additionally, active denitrifying microflora were detected. These oxidize Fe^{+2} to Fe^{+3} anaerobically, opening up the possibility of a deep-set Fe^{+3} clog.

The effectiveness of conventional mechanical development used in past treatments was difficult to evaluate based on file information, but the approach to treatment prior to 1998 was more focused on chemical application than development action. Less-than-optimal redevelopment likely resulted in incomplete removal of clogging mass from the gravel pack and formation.

Because (1) the wells appeared to be fundamentally sound, and (2) the cost of rehabilitation to restore performance was favorable compared to new construction, the consultant recommended rehabilitation over either well reconstruction or abandonment and new construction. Target yields and specific capacities were calculated based on pumping goals (production needed and maximum drawdowns) and power efficiency (using Helweg et al. 1983 formulas).

Based on the analysis of causes, a BCHT program (process documented in Leach et al. 1991; Smith 1995; Alford and Cullimore 1999) was recommended to break through the expected clogging material and restore performance. The BCHT process (which employs a mixture of chemicals, heated on injection) has a history of effectiveness on difficult well clogs promoted by the slime-forming biofouling, similar to that detected in the South Well Field tests.

In this case, the treatment comprised a combination of acetic acid (amended to reduce pH to <2) and nonphosphate polyelectrolyte (ARCCsperser CB-4 and PM-30, ARCC, Daytona Beach, Fla.), jetted in at 180°F (at the nozzle), with a program of extensive mechanical development using double surge block and airlift pumping. This program was used on both wells No. 1 and No. 3.

Because of cost differences and as a comparison, well No. 2 was treated with HCl, calcium hypochlorite and development. Phosphate-containing compounds were not used in any treatments but replaced as surfactants by the ARCCsperser products.

Well No. 1 was in extremely poor shape prior to cleaning (capacity = 8.2 at 402 gpm). After the initial chemical charge, with minimal development, specific capacity fell to 5 gpm/ft. This was most likely due to development action collapsing clogging material against the screen, but it resulted in some short-term concerns. Surging and airlift began a recovery over one week to 16.1 gpm/ft at 737 gpm, an economically viable level of performance for 1 mgd, based on calculations. The effectiveness of development was hindered by (1) a delay in commencement of development after chemical loading because of scheduling (under BCHT, development is most effective when commenced while the solution is still hot), (2) some stoppage in development due to mechanical problems and process "choke points," and (3) (initially) the effectiveness of development with the tools at hand.

Well No. 3 provided the most effective immediate response to the BCHT approach. After one chemical treatment pass and three days of development, capacity was restored to 55 gpm/ft at 770 gpm from 15.6 gpm/ft at 686 gpm. Capacity reached 61.3 gpm/ft on July 23, 1998, when a large amount of silica sand was pumped in. The screen was repaired, reducing capacity somewhat. Overall, performance was restored to somewhat less than 1987 post-treatment levels by the end of treatments in 1998.

Well No. 2 was treated differently, using HCl, alternating with an alkaline (soda) and chlorine steps, with three days' development. Success in immediate redevelopment

response here was also evident in increased specific capacity: from 22.8 gpm/ft at 800 gpm to 38.7 gpm/ft at 1,002 gpm.

Comparing the effectiveness of the two chemical regimes will require evaluation over time. Acid-amended acetic acid has been shown in over 3,000 well applications to perform better than HCl and chlorine on very advanced slime-forming biofouling. However, in wells where the clogging is not compacted, as in well No. 2, various chemical treatments can have similar results. History with aggressive biofouling well environments shows that the benefits of both BCHT (and the amended acetic acid chemical choice) and effective redevelopment come with delayed decline in performance after rehabilitation, rather than in obvious immediate effects.

Long-term effectiveness of these treatments in the South Well Field will depend on follow-up by the Elkhart DPWU. The following recommendations are being considered by the DPWU:

1. An immediate short-term follow-up should be additional low-intensity redevelopment of each well in the South Well Field in the next two years to complete the work begun with the 1998 rehabilitation actions. Each well should respond to additional development and light chemical treatment by increasing in performance if it is not permitted to decline in performance first.
2. For further benefit, a program of professionally developed, city administered, maintenance evaluation and treatment is essential in the South Well Field, and by extension, all three well fields. A continued resumption in performance decline can be expected if no maintenance treatment actions are taken. The lapse in preventive maintenance treatments after 1992 almost certainly contributed to the state of the wells prior to the 1998 treatments.
3. To best achieve these goals, all monitoring, treatment, and repair activities should be planned as part of a system-wide strategic well field maintenance program that is both systematic and effective.
4. Within the maintenance plan, personnel training and well field equipment modification are recommended to make the process easier and more effective.
5. A noncontractor advisory role on major treatment events: Professional assistance in this area by people highly experienced in well maintenance and rehabilitation helps to assure that a well field operator's objectives and best interests are served.

The Elkhart experience clearly shows what happens when wells are permitted to decline in performance. The experience in Elkhart's South Well Field should not be considered unique. Prospects for success in well maintenance in other well fields also depend on the kind of analysis, review, and planning documented in this manual. As Elkhart has, any water supplier can benefit from (1) honest and complete scrutiny of successes (complete and incomplete), lapses, and failures in its maintenance history, and (2) taking advantage of the many improvements now available in the practice of well analysis, treatment, and maintenance.

Life-Cycle Cost Analysis

Life-cycle cost (LCC) analysis is a process of estimating costs of an installation or component (such as a pump) over a projected service life. It can be used for budgeting purposes and for comparing alternatives for design, component selection, and O&M strategies. LCC analysis incorporates costs of initial equipment purchase and installation, power to operate, cost of other expendables, service, and other identifiable costs. Therefore, it takes the "C equation" C/B process described in Helweg et al. (1983) and adds original purchase and expendables costs and projects over time.

As mentioned, LCC analysis can be used for budget projection in planning an installation such as a new water well and for comparison to periodic costs for well rehabilitation. The process can also be used to compare the LCC that result from different choices, such as those for well casing and screen, column pipe, or pumps, or for choices in well rehabilitation.

Many examples are available. A running theme in LCC for water wells (due to their relatively long service lives) is that (1) selection of best available initial quality in construction materials and components, (2) any actions that result in higher power-per-unit water efficiency, and (3) actions that extend well service life result in lower LCC compared to alternatives.

Calculating periodic costs (Helweg et al. 1983) and LCC can be extended to consider profitability, that is, when a well user (such as a water utility) sells water for a price or creates *value* such as a crop or product for sale (Smith and Comeskey 2009). With a change in LCC, projected profitability (income minus gross and net profits) due to an action can be compared over time. For example, replacing a low-efficiency well with a higher efficiency and higher producing well (a capital cost) may result in greater profitability and/or shorter return on investment over time. An action such as well rehabilitation may actually result in a calculated economic value if more salable or usable water can be generated for the same power consumption.

Well Decommissioning/Abandonment

An extension of LCC is determining when to “pull the plug” and to take a well out of service. The Elkhart, Ind., case history was one such exercise. At the start of the project, the well was uneconomical to operate at the flow rate it could generate at the then-current specific capacity. The project was an attempt to raise specific capacity to a useful level so that power-expanded-per-flow rate was economically viable. In this case, the well was returned to a suboptimal but economically viable state. The well was indeed decommissioned some years later when clogging again became excessive.

A well may also be nonviable if it experiences structural damage or excessive corrosion. In these cases, efforts to rehabilitate may be counterproductive (causing collapse) or ineffective (clean but still plagued with corrosion holes). The economics of wells is such that smaller, shallower, less expensive wells are more typically abandoned and decommissioned than deeper, larger, and more valuable wells.

When a well is taken out of service and abandoned, it may be held in reserve. However, the deteriorating conditions that made the well nonviable will continue. The more proper response is to securely seal the well—typically known as decommissioning. In decommissioning sealing, equipment in the well is removed, the well disinfected and accumulated debris removed, and the well is securely sealed. Sealing may take many forms and is discussed in more detail in NGWA (1998). In any case, the well bore is filled, either entirely or concluding in the shallower parts of the well with an impermeable permanent seal. This is typically neat cement or high-solids bentonite.

U.S. states and Canadian provinces and other regional jurisdictions typically have defined rules for well abandonment decommissioning sealing. These should be followed explicitly, performed by qualified water well contractors, and the results recorded for future reference. A well abandonment or decommissioning record may need to be filed with the state or other jurisdiction, but such records should also be kept in the water utility’s records and the position of the sealed decommissioned well permanently marked.

REFERENCES

- Alford, G. and D.R. Cullimore. 1999. *The Application of Heat and Chemicals in the Control of Biofouling Events in Wells*. Boca Raton, Fla.: CRC Press/Lewis Publishers.
- Bloetscher, F., with G.M. Witt, A.E. Gerhardt, and C.P. Dodd. 1998. Prevention of Biofouling in Membrane Water Treatment Plants. *Proc. of AWWA Annual Conference and Exposition*. Dallas, Texas.
- Borch, M.A., S.A. Smith, and L.N. Noble. 1993. *Evaluation, Maintenance, and Restoration of Water Supply Wells*. Denver, Colo.: American Water Works Association Research Foundation.
- Bruin, J. and Hudson, H.E. 1955. "Selected Methods for Pumping Test Analysis," Report of Investigation 25, Illinois State Water Survey.
- Cullimore, D.R. 2008. *Practical Ground Water Microbiology*, 2nd ed. Boca Raton, Fla.: CRC Press/Lewis Publishers.
- Cullimore, D.R. 2000. *Practical Atlas for Bacterial Identification*, Boca Raton, Fla.: CRC Press/Lewis Publishers.
- Driscoll, F.G. 1986. *Groundwater and Wells*. St. Paul, Minn.: Johnson Division.
- Ehrlich, H.L. and D.K. Newman. 2009. *Geomicrobiology*. Boca Raton, Fla.: CRC Press.
- Gariboglio, M.A. and S.A. Smith. 1993. *Corrosión e incrustación microbiológica en sistemas de captación y conducción de agua: aspectos teóricos y aplicados*. Serie Investigaciones Aplicadas Buenos Aires, Argentina; Consejo Federal de Inversiones.
- Ground Water Science. 2000. Evaluation of Problems with Closed Basin Division Salvage Wells, Rehabilitation Method Tests, Methods for Monitoring Well Deterioration, and Recommendations for Preventive Maintenance and Rehabilitation. A Comprehensive Report. Prepared for US Department of Interior. Denver, Colo.: Bureau of Reclamation.
- Helweg, O.J., V.H. Scott, and J.C. Scalmanini. 1983. *Improving Well and Pump Efficiency*. Denver, Colo.: American Water Works Association.
- Houbin, G. and C. Treskatis. 2007. *Water Well Rehabilitation and Reconstruction*. New York, N.Y.: McGraw-Hill.
- Krusemann, G.P. and N.A. de Ridder. 1994. Analysis and Evaluation of Pumping Test Data, ILRI Publication 47. International Institute for Land Reclamation and Improvement. Wageningen, The Netherlands.
- Leach, R., A. Mikell, C. Richardson, and G. Alford. 1991. Rehabilitation of Monitoring, Production and Recharge Wells. *Proc. 15th Annual Army Environmental R&D Symposium (1990)*. CETHA-TS-CR-91077. US Army Toxic and Hazardous Materials Agency. Aberdeen Proving Grounds, Maryland. pp. 623-646.
- Lennox, J.B. 2007. *Application of Well Condition Assessment and Rehabilitation Techniques Application of Well Condition Assessment and Rehabilitation Techniques*. Denver, Colo.: AWWA and Awwa Research Foundation.
- National Ground Water Association (NGWA). 1998. *Manual of Water Well Construction Practices*, 2nd ed. Westerville, Ohio: NGWA.
- Roscoe Moss, Co. 1990. *Handbook of Groundwater Development*. New York, N.Y.: Wiley-InterScience.
- Schneiders, J.H. 2003. *Chemical Cleaning, Disinfection and Decontamination of Water Wells*. St. Paul, Minn.: Johnson Screens Inc.
- Smith, S.A. 1992. *Methods for Monitoring Iron and Manganese Biofouling in Water Supply Wells*. Denver, Colo: AWWA Research Foundation.
- Smith, S.A. 1995. *Monitoring and Remediation Wells: Problem Prevention, Maintenance, and Rehabilitation*. Boca Raton, Fla.: CRC Press/Lewis Publishers.
- Smith, S.A. 1996. Monitoring Biofouling in Source and Treated Waters: Status of Available Methods and Recommendations for Standard Guide. *Sampling Environmental Media*, ASTM STP 1282. J.H. Morgan, Ed. West Conshohocken, Pa.: American Society for Testing and Materials. pp. 158-175.
- Smith, S.A. 2012. Recent Innovations in Well Rehabilitation. Bluffton, Ohio: Ground Water Science. Accessed at <http://www.groundwaterscience.com>.
- Smith, S.A. and A.E. Comeskey. 2009. *Sustainable Wells: Maintenance, Problem Prevention, and Rehabilitation*. Boca Raton, Fla.: Taylor & Francis CRC Press.
- Sterrett, R.J. 2007. *Groundwater and Wells*, 3rd Ed. New Brighton, Minn.: Johnson Screens.
- SWWI. 2000. City of North Battleford, Well 15, 1997 Field Test of UAB Water Well Treatment Technology. Regina, Sask., Canada: PFRA Technical Services Earth Science Division.
- Williams, D.E. 1985. Modern Techniques in Well Design. *Jour. AWWA* 77(9).
- Williams, E.B. 1981. Fundamental Concepts of Well Design. *Ground Water* 19(3): 527-542.

ADDITIONAL READING

- Ahmad, R., A. Amirtharajah, A. Al-Shawwa, and P.M. Huck. 1998. Effects of backwashing on biological filters. *Jour. AWWA* 90(12): 62–73.
- Arihood, L.D. and D.A. Cohen. 1997. Geohydrology and simulated groundwater flow in northwestern Elkhart County, Indiana. Preliminary Water Resources Investigation Report. Indianapolis, Ind.: US Geological Survey.
- Goldrabe, J.C., R.S. Summers, and R.J. Miltner. 1993. Particle removal and head loss development in biological filters. *Jour. AWWA* 85(12): 94ff.
- Imbrigiotta, T.E. and A. Martin, Jr. 1981. Hydrologic and Chemical Evaluation of the Ground-Water Resources of Northwest Elkhart County, Ind. Water Resources Investigations Report 81–53. Indianapolis, Ind.: US Geological Survey.
- Smith, S.A. and A.E. Comeskey. 2001. Field Documentation of Improvements in Well Performance Using Innovative Rehabilitation Methods. *Proc. of the World Water and Environmental Resources Conference*. ASCE Environmental and Water Resources Institute.
- Wang, J.Z., R.S. Summers, and R.J. Miltner. 1995. Biofiltration performance: Part 1, Relationship to biomass. *Jour. AWWA* 87(12): 55ff

This page intentionally blank.

Groundwater Quality

Groundwater quality is as important as the quantity of supply. Groundwater near the land surface, in unconfined aquifer systems, is ordinarily subject to active replenishment and circulation as a result of precipitation. Because rainfall is acidic, water that infiltrates into the soil dissolves rock minerals and organic matter in the process. Rainfall can also carry contaminants in the soil into the groundwater. As a result, groundwater contains a variety of chemicals resulting from natural sources, as well as from overlying land uses and local management practices.

CHEMICALS IN GROUNDWATER

The most common chemical constituents of natural surface and groundwater and their effects are listed in Table 8-1. Only small to moderate amounts of these substances occur in most fresh, surface water sources. Moderate amounts of dissolved minerals make water more palatable, as mineral-free water tastes flat to most people and distilled water is highly corrosive to piping and storage materials, a constant problem for water utilities. Minerals are also important to human health and plant and animal growth.

The chemical, physical, biological, and radiological quality of groundwater varies widely, and virtually any chemical could be found in groundwater. Acceptable quality depends on water use and regulatory requirements. For example, the criteria for safe and healthy drinking water are much more stringent than for water used for industrial and agricultural purposes.

Chemical and Physical Characteristics

Groundwater possesses chemical and physical characteristics due to characteristics of the water and the physical and geochemical setting of the groundwater. The most common of these are hydrogen-ion concentration (pH), temperature, hardness, and gas content. These characteristics are discussed in the following paragraphs.

pH. Most groundwater has a pH value ranging from 6.0 to 8.5. Groundwater having a pH greater than 9.0 is unusual, except when contaminated. Many thermal springs yield water with a pH lower than 6. River water unaffected by contaminants generally has a pH between 6.5 and 8.5. Special techniques are necessary to accurately measure pH (Wood 1976).

Temperature. In contrast to the seasonal and diurnal fluctuations of surface-water temperature, the temperature of groundwater is constant. The exception is the temperature of groundwater near the surface, which may fluctuate several degrees during the year in response to the seasons. A constant groundwater temperature helps maintain the palatability of drinking water.

The mean temperature of groundwater at shallow depths is generally 2°F to 3°F (17°C to 16°C) above the mean annual air temperature, except in semi-tropical areas (like Florida, where the opposite may be true). Below this zone of solar influence, the temperature of groundwater increases at a rate of approximately 1°F (0.6°C) for each 64 ft (20 m) of depth. This increase mirrors the geothermal gradient of the earth's crust. With few exceptions, groundwater pumped from deep wells has higher temperatures than that pumped from shallow wells.

Table 8-1 The principal natural chemical constituents in water, concentrations, and effects of usability

Constituent	Concentrations in Natural Water	Effects on Usability of Water
Silica (SiO ₂)	Ranges generally from 1.0 to 3.0 mg/L, although as much as 100 mg/L is fairly common; as much as 4,000 mg/L is found in brines.	In the presence of calcium and magnesium, silica forms a scale in boilers and on steam turbines that retards heat and fluid flow; the scale is difficult to remove. Silica may be added to soft water to inhibit corrosion of iron pipes.
Iron (Fe)	Groundwater having a pH of less than 8.0 may contain 10 mg/L; rarely as much as 50 mg/L may occur. Acid water from thermal springs, mine wastes, and industrial wastes may contain more than 6,000 mg/L.	More than 0.1 mg/L precipitates after exposure to air; causes turbidity, stains plumbing fixtures, laundry and cooking utensils, and imparts objectionable tastes and colors to foods and drinks. More than 0.2 mg/L is objectionable for most industrial uses.
Manganese (Mn)	Generally 0.20 mg/L or less. Groundwater and acid mine water may contain more than 10 mg/L. Water at the bottom of a stratified reservoir may contain more than 150 mg/L.	More than 0.2 mg/L precipitates on oxidation; causes undesirable tastes, deposits on foods during cooking, stains plumbing fixtures and laundry, and fosters growth in reservoirs, filters, and distribution systems. Most industrial users object to water containing more than 0.2 mg/L.
Calcium (Ca)	Averages about 15 mg/L in surface water, higher in groundwater. As much as 600 mg/L in some western streams; brines may contain as much as 75,000 mg/L.	Calcium and magnesium combine with bicarbonate, carbonate, sulfate, and silica to form heat-retarding, pipe-clogging scale in boilers and in other heat-exchange equipment. Calcium and magnesium combine with ions of fatty acid in soaps to form soap suds; the more calcium and magnesium, the more soap required to form suds. A high concentration of magnesium has a laxative effect, especially on new users of the supply.
Magnesium (Mg)	As much as several hundred milligrams per liter in some western streams; ocean water contains more than 1,000 mg/L and brines may contain as much as 57,000 mg/L.	
Sodium (Na)	As much as 1,000 mg/L in some western streams; about 10,000 mg/L in sea water; about 25,000 mg/L in brines.	More than 50 mg/L sodium and potassium in the presence of suspended matter causes foaming, which accelerates scale formation and corrosion in boilers. Sodium and potassium carbonate in recirculating cooling water can cause deterioration of wood in cooling towers. More than 65 mg/L of sodium can cause problems in ice manufacture.
Potassium (K)	Generally less than about 10 mg/L; as much as 100 mg/L in hot springs; as much as 25,000 mg/L in brines.	

(Table continued next page)

Table 8-1 The principal natural chemical constituents in water, concentrations, and effects of usability (continued)

Constituent	Concentrations in Natural Water	Effects on Usability of Water
Carbonate (CO ₃)	Commonly 0 mg/L in surface water; commonly less than 10 mg/L in groundwater. Water high in sodium may contain as much as 50 mg/L of carbonate.	Upon heating, bicarbonate is changed into steam, carbon dioxide, and carbonate. The carbonate combines with alkaline earths—principally calcium and magnesium—to form a crust-like scale of calcium and magnesium carbonate that retards flow of heat through pipe walls and restricts flow of fluids in pipes. Water containing large amounts of bicarbonate and alkalinity is undesirable in many industries.
Bicarbonate (HCO ₃)	Commonly less than 500 mg/L; may exceed 1,000 mg/L in water highly charged with carbon dioxide.	
Sulfate (SO ₄)	Commonly less than 1,000 mg/L except in streams and wells influenced by acid mine drainage. As much as 200,000 mg/L in brines.	Sulfate combines with calcium to form an adherent, heat-retarding scale. More than 250 mg/L is objectionable in water in some industries. Water containing about 500 mg/L of sulfate tastes bitter; water containing about 1,000 mg/L may be cathartic.
Chloride (Cl)	Commonly less than 10 mg/L in humid regions; tidal streams contain increasing amounts of chloride (as much as 19,000 mg/L) as the bay or ocean is approached. About 19,300 mg/L in sea water; and as much as 200,000 mg/L in brines.	Chloride in excess of 150 mg/L imparts a salty taste. Concentrations greatly in excess of 150 mg/L may cause physiological damage. Food processing industries usually require less than 250 mg/L. Some industries—textile processing, paper manufacturing, and synthetic rubber manufacturing—desire less than 100 mg/L.
Fluoride (F)	Concentrations generally do not exceed 10 mg/L in groundwater or 1.0 mg/L in surface water. Concentrations may be as much as 1,600 mg/L in brines.	Fluoride concentration between 0.6 mg/L and 1.7 mg/L in drinking water has a beneficial effect on the structure and resistance to decay of children's teeth. Fluoride in excess of 1.5 mg/L in some areas causes mottled enamel in children's teeth. Fluoride in excess of 6.0 mg/L causes pronounced mottling and disfiguration of teeth.
Nitrate (NO ₃)	In surface water not subjected to pollution, concentration of nitrate may be as much as 5.0 mg/L but commonly is less than 1.0 mg/L. In groundwater, the concentration of nitrate may be as much as 1,000 mg/L where polluted but generally less than 50 mg/L.	Water containing large amounts of nitrate (more than 100 mg/L) is bitter tasting and may cause physiological distress. Water from shallow wells containing more than 45 mg/L has been reported to cause methemoglobinemia in infants. Small amounts of nitrate help reduce cracking of high-pressure boiler steel.
Dissolved solids	The mineral constituents dissolved in water constitute the dissolved solids. Surface water commonly contains less than 3,000 mg/L; streams draining salt beds in arid regions may contain in excess of 15,000 mg/L. Groundwater commonly contains less than 5,000 mg/L, and most of it at shallow depths contains less than 1,000 mg/L; some brines contain as much as 300,000 mg/L.	More than 500 mg/L is undesirable for drinking and many industrial uses. Less than 300 mg/L is desirable for dyeing of textiles and the manufacture of plastics, pulp paper, and rayon. Dissolved solids cause foaming in steam boilers; the maximum permissible content decreases with increases in operating pressure.

Source: Adapted from Durfor, C.N., and E. Becker (1964).

Hardness. Hardness is derived mainly from calcium and magnesium, although other divalent metallic cations like iron and manganese may also contribute. These metallic ions inhibit lathering by reacting with soap to form undesirable precipitates and can combine with certain anions in boiler water to form efficiency-robbing scale on tank walls and in pipes.

In aquifers containing hard water, lowering the water level in a well during pumping and the corresponding reduction in water pressure at the intake screen may precipitate calcium and magnesium compounds that clog the well screen. In an unscreened well, the precipitates may clog the openings in the aquifer immediately adjacent to the well bore with comparable reduction in inflow of water.

A number of similar numerical scales for rating water hardness have been devised and published, including, for example, the following scale (Durfor and Becker 1964):

Hardness Range <i>mg/L of CaCO₃</i>	Description
0–60	Soft
61–120	Moderately hard
121–180	Hard
More than 180	Very hard

Hardness of water used for domestic purposes is not objectionable in concentrations below about 100 mg/L. The hardness of groundwater throughout much of the United States is less than 200 mg/L. However, groundwater in gypsiferous and carbonate bedrock formations of the north central region (including North Dakota, South Dakota, south Texas, Iowa, and parts of surrounding states) and groundwater in other parts of the nation that is underlain by sedimentary rocks rich in calcium and magnesium generally exceed this level. In these areas, hardness levels of 300 mg/L are common, and levels as high as 1,000 mg/L occur in some places.

Gases. As precipitation falls through the atmosphere, it comes in contact with soluble gases that may combine with the water droplets. Dust and other particulate matter suspended in the air add chemical constituents to the water. The combination of precipitation and carbon dioxide (CO₂) forms carbonic acid (H₂CO₃), increasing the acidity of precipitation. Additional carbon dioxide, originating from organic processes at the land surface and in the soil zone, dissolves in groundwater, further increasing its acidity and its capacity to dissolve mineral matter. Carbon dioxide (CO₂) may be an indicator or biological activity.

Oxygen (O₂) and hydrogen sulfide (H₂S) are other important gases that occur in groundwater. The concentration of dissolved oxygen in shallow groundwater is usually less than 10 mg/L, and in deep-lying groundwater it may be virtually absent. Dissolved oxygen is harmless to health and may improve the palatability of water. Dissolved oxygen does contribute to water's corrosiveness to metals, most aggressively where carbon dioxide or low pH are present. Hydrogen sulfide gas is generated in groundwater by decomposing natural organic substances and sulfate-reducing bacteria acting on organic materials. Hydrogen sulfide is corrosive in the gaseous state, and combines with water to form a weak acid solution.

Methane (CH₄), generated by the decomposition of vegetation and other organic materials, is prevalent in groundwater and soil moisture zones in small concentrations. Larger quantities, sufficient for domestic or small industrial heating and energy requirements, may be formed in peat bogs, coal mines, or large landfills containing thick deposits of decomposing organic wastes. Fires and explosions in mines, basements, water wells, and petroleum wells often are attributable to the accumulation of methane gas.

GROUNDWATER CONTAMINATION

Groundwater contamination is a widespread and challenging problem. Some contaminants are natural, like arsenic and radon gas that must be addressed. Both natural and man-made contaminants can often flow undetected into groundwater aquifers, migrating through the aquifer until a sizable portion of the aquifer has become degraded. Even where physically and economically practical, rehabilitating a contaminated aquifer is difficult, complicated, and expensive. In arid regions, where water resources are limited, aquifer remediation may be the only option for a reliable, long-term water source.

Irreversible damages to some of the nation's groundwater resources has stimulated efforts to reduce the influx of contaminants at their sources. Prevention is simpler, more effective, and less costly than cleanup measures. However, even after elimination of contamination sources, aquifers can remain contaminated for decades as a result of the slow rate of groundwater movement and the corresponding slow rate of dilution and flushing of contaminating substances. Biodegradation, the breakdown of contaminants by microorganisms in the subsurface, is commonly used today for cleaning up contamination in many areas.

Biological Contaminants

There are more than 100 microorganisms that are considered human pathogens (Feacham et al. 1981), most of which are introduced into the body via ingestion, inhalation, dermal contact, or entry through wounds or body orifices (Hurst 1996). Infected persons excrete large numbers of these pathogens, which often find their way into ground and surface waste systems. Each organism has a different dose-response relationship with a vastly different threshold dose for infection. Typically, bacterial infections require very high quantities of these organisms, while with certain viruses, one organism is sufficient to cause infection. Fortunately, available studies indicate that bacteria are generally removed during wastewater treatment and disinfection, but depending on the treatment process employed, viruses may only experience a 50 percent removal rate (Yates et al. 1987).

Relevant classes of microorganisms. Microorganisms associated with waterborne disease can be broken into four groups: amoebas, protozoans, bacteria, and viruses. Each has unique environmental fate and effect characteristics in groundwater systems. The following sections summarize each genre.

Amoebas. Amoebas should not constitute a threat to groundwater systems because they are too large to move in the subsurface. However if a well is connected to a surface water source (under the influence of surface waters), the potential exists for cross contamination. Free-living amoebae have been detected in a large number of man-made water systems, including drinking water distribution systems (Loret et al. 2008). Free-living amoebae may house bacteria including pathogens, including emerging pathogens responsible for respiratory diseases. Some of the amoebas may be pathogenic. Yoder et al. (2010) note that *Naegleria fowleri* is a free-living microscopic amoeba that can cause a rare, but fatal infection of the brain called primary amebic meningoencephalitis (PAM). *Naegleria fowleri*, commonly referred to as the *brain-eating amoeba*, usually infects people when contaminated water enters the body through the nose. Drinking water does not pose a threat, however a reservoir might. Other amoebas may contribute to the protection, survival, and dissemination of pathogenic bacteria in water systems, despite the application of disinfection treatments (Loret and Greub 2010).

Protozoans. Protozoans and their cysts are common in surface waters and are much larger than either viruses or bacteria. The cyst stage is an encapsulation that protects protozoans from harsh environmental conditions, such as drought in the case of duck botulism. *Cryptosporidium* and *Giardia lamblia* are the two protozoans most studied because

of their presence in drinking water (generally unfiltered surface water), and their link to waterborne-illness outbreaks (Milwaukee 1993). *Giardia lamblia* is believed to be the most common protozoan pathogen present in surface waters. Its population appears to remain constant throughout the year in surface water impoundments (Rose and Carnahan 1992). Neither *Cryptosporidium* nor *Giardia lamblia* appears to be a common groundwater problem except in those groundwaters under the influence of surface waters. Both organisms are generally believed to be too large to move significant distances in groundwater systems, and, as a result, they will not be discussed further.

Bacteria. Bacteria are the most widely distributed life form on Earth (Chapelle 1993). Chapelle notes that bacteria are extremely important to consider in groundwater projects because they inhabit virtually every subsurface environment, producing methane gas and consuming organic rich soils. The key bacteria responsible for waterborne diseases include *Legionella*, the Pseudomonads, *Klebsiella*, *Escherichia coli*, *Shigella*, *Enterobacter*, *Salmonella*, and *Vibrio cholerae*, some of which are pathogenic. The pathogenic bacteria are approximately 0.4 μm to 14 μm long and 0.2 μm to 12 μm wide, which means they are much smaller than protozoans, thus making it easier for them to move in the subsurface. Most of them also belong to a classification called *gram negative bacteria*, which are found extensively in subsurface situations.

Bacteria have their own enzyme equipment and most are motile, which allows them to move in the subsurface. Bacteria reproduce by splitting into daughter cells, each of which continues to split, forming additional bacteria and eventually a biomass. The respiration ability of bacteria permits them to survive in soils and aquifers. There are three respiration types: (1) those bacteria that use inorganic chemicals to serve as electron acceptors such as oxygen, ferric iron, and sulfates, (2) those that are aerobic—requiring oxygen, and (3) those that are facultative anaerobes—capable of fermentation or using oxygen as electron receptors (Chapelle 1993). The respiration mechanism is important because it affects the ability of bacteria introduced to colonize wells and the aquifer; it also affects the growth rate of bacteria indigenous to the aquifer as a result of the constituents introduced.

The most common opportunistic bacterial pathogen is *Pseudomonas aeruginosa*, which has a colonization rate of 2.6 to 24 percent of the human population but rarely is viewed as a public health threat in water supplies (Lister et al. 2009). However, it is the most common infection in hospitals. *Pseudomonas aeruginosa* is an extraordinarily versatile organism that will live in nearly any environment. *Pseudomonas aeruginosa* is a facultative anaerobe that requires no specific vitamins, growth factors, or amino acids. However, the most important concern of this pathogen is its ability to create a slime matrix that encapsulates other bacteria and protects them from otherwise harsh aquifer conditions. Commonly found bacteria in the subsurface include *Gallionella* and *Desulfovibro*. *Gallionella* is an obligate aerobe that obtains energy by oxidizing dissolved ferrous iron to form ferric oxyhydroxides—meaning it will be a problem in wells constructed with steel materials (Chapelle 1993). *Desulfovibro* is a sulfur-reducing bacteria that uses hydrogen or simple organic compounds as an energy source and sulfates as the terminal electron acceptor, which leads to hydrogen sulfide gas formation (Chapelle 1993). Other bacteria may also colonize the slime matrix (Bloetscher et al. 1997).

Viruses. Viruses are molecular entities that possess little or no enzymatic equipment, no energy capability, and no mechanisms for synthesis. Typically, they are 20 nm to 300 nm in size. They cannot reproduce themselves, requiring a host cell to multiply. Pathogenic viruses tend to be smaller than other viruses and can only be seen with an electron microscope: most are 27 nm to 70 nm in size and are symmetrical in shape. The majority of viruses tend to be resistant to chloroform, but may be inactivated to various degrees

during wastewater treatment processes or by chlorine, bromine, ozone, ultraviolet light, and/or formaldehyde (Block 1989). Viruses are conserved at -20°C (Block 1989).

All viruses are composed of nucleic acid and either RNA or DNA (but not both), which allows them to replicate in other cells, including bacteria—when they are called *bacteriophages* (Chapelle 1993). Viruses are obligate parasites, always searching for the correct host cell that will allow the virus to multiply. Viruses cannot survive or infect without such a host organism or cell (Chapelle 1993).

Transmission of viruses occurs in one of the following ways (in order of prevalence):

- Fecal to oral pathway
- Person to person
- Respiration

Viruses have been found in a variety of USEPA underground aquifer studies including the following:

- 23 percent of wells in one study were positive for enterovirus cell cultures
- 15 percent of Mississippi River–related wells (some flooded previously)
- 16 percent of wells designated to develop PRC methods
- 4 percent of karst formation wells studied

Human viruses found in natural waters are almost always associated with fecal material eliminated from the bodies of infected individuals (Sellwood and Dadswell, 1992). Therefore, virus concentrations in wastewater are high. Over a million plaque-forming units (PFUs) of viruses are eliminated per gram of fecal matter from infected individuals. The number rises to 10 billion for those infected with the *rotavirus* species (Yates et al. 1985). Survival of these viruses demonstrates that *rotaviruses* are sufficiently hardy to survive wastewater treatment and disinfection processes—thus, the regulatory concern regarding these organisms in injection programs.

Major viruses of concern are: Hepatitis A, Coxsackie, ECHO, Norwalk, SRSV, *rotaviruses* and reoviruses (Block 1989). While vaccines may be available for some viruses, the wild strains never disappear from the environment, indicating that continued vaccinations are important (Bouwer 1991).

CHEMICAL CONTAMINANTS

Major chemicals impacting groundwater quality can be divided into organic and inorganic species. Table 8-2 shows primary standards established for drinking water in the United States. The table reflects the wide spectrum of organic and inorganic toxic chemicals that require surveillance and regulatory measures. There are also a host of secondary standards. State (or provincial in Canada) standards should be investigated further.

Organics include most compounds of carbon such as hydrocarbons but exclude the metallic carbonates such as calcium carbonate (CaCO_3) and sodium carbonate (Na_2CO_3). Inorganic compounds include the remainder of substances, such as nitrate (NO_3), lead, and mercury. Inorganic chemicals with a federal maximum contaminant level (MCL) can be divided into four major groups: nitrogen, total dissolved solids (TDS), minerals, and radionuclides. Organics can similarly be divided into two main groups: volatile organic compounds (VOCs) and pesticides.

Inorganic Compounds

Nitrogen group. Nitrogen is a constituent of all proteins and is widely distributed in plants and animals. Major sources include

- irrigated agriculture
- dairy and livestock wastes
- sanitary wastes (septic tanks in unsewered areas and wastewater treatment plant discharges)
- landfill leachate
- some manufacturing wastes that are disposed of in waste pits

Three MCLs have been established for nitrate, nitrite, and total nitrogen existing in the forms of nitrate and nitrite. Nitrate has long been regulated because of its acute human health effect of impairing the ability of blood to carry oxygen. For example, nitrogen has affected approximately one-half of the 3,500 drinking water wells in a Southern California region. Seventy-six bil gal per year or 233,000 acre-ft/yr is associated with 469 wells where the MCL for at least one nitrogen standard has been exceeded. Additionally, 32 percent of the production, 144 bil gal per year or 442,000 acre-ft/yr, comes from 1,180 wells where nitrogen has been detected but at less than the MCLs.

Table 8-2 MCLs for a variety of organic and inorganic chemicals

Constituent	Maximum Concentration (in mg/L unless specified)
Arsenic	0.01
Barium	2
Cadmium	0.0050
Chromium	0.1
Lead	0.015
Mercury	0.002
Nitrate (as N)	10
Selenium	0.05
Silver (SMCL)	0.10
Fluoride	4.0
Total THMs	0.08
Endrin	0.002
Lindane	0.0002
Methoxychlor	0.04
Toxaphene	0.003
2,4-D	0.1
2,4,5-TP (Silvex)	0.05
Combined radium-226 and -228	05 pCi/L*
Trichloroethylene	0.005
Carbon tetrachloride	0.005
Vinyl chloride	0.002
1,2-Dichloroethane	0.005
Benzene	0.005
<i>p</i> -Dichlorobenzene	0.075 µg/L
1,1-Dichloroethylene	0.007
1,1,1-Trichloroethane	0.2 µg/L

*Picouries per liter.

Source: <http://www.epa.gov/ogwdw/consumer/pdf/mcl.pdf>

Total dissolved solids (TDS). The predominant substances in municipal water supplies are inorganic minerals. Together these minerals constitute TDS and commonly include sodium, calcium, magnesium, bicarbonate, sulfate, chloride, and silica. A secondary MCL for TDS (500 mg/L) has been established because it is an important index of groundwater quality and usability. High TDS impairs aesthetics and practical uses of a municipal supply. The TDS component of most concern is salt. As the TDS increases, the amount of sodium and chlorides increase. In brackish water, salt is usually at least two thirds of the TDS value. Salt, unlike most other minerals, cannot be removed chemically. Reverse osmosis membranes are required.

Minerals. Minerals occur naturally in the earth's crust and dissolve into water. The minerals group has individual chemical MCLs for both major minerals and trace elements, all of which may reach elevated concentrations in groundwater through human activities. Major minerals include: manganese, sulfate, iron, chloride, and fluoride. Fluoride is the only major mineral with a federal MCL. Trace elements usually include: cadmium, chromium, barium, beryllium, copper, lead, selenium, mercury, aluminum, and silver. Several trace elements have MCLs. They are discussed in the following paragraphs.

Major minerals dissolve readily in water and become concentrated in agricultural runoff and wastewater treatment plant discharges, and through evaporation of seawater and freshwater bodies. Sulfates and chlorides are regulated with secondary standards because of aesthetic considerations, due to the cathartic effect on humans and the salty taste imparted to water. Fluoride is regulated because too high a level may cause mottled teeth enamel and osteosclerosis.

Trace elements in the minerals group with MCLs include silver, mercury, arsenic, and selenium. Trace elements can damage living organisms at low concentrations and tend to accumulate in the food chain. Trace elements have a wide variety of uses, including mercury in paints and batteries, and cadmium in electroplating. Selenium, although an essential trace element in animal diets, is toxic at high concentrations.

Lead is a trace element that the USEPA has determined to be a health concern at certain levels of exposure, especially for children and pregnant women. While lead-based paint is the major source of lead in the environment, lead can also come from the corrosion of household plumbing that contains lead pipes or copper pipes joined by lead solder. State and federal laws now require that only lead-free solder and other lead-free material be used when building or repairing plumbing systems.

Chromium is a naturally occurring element, the eleventh most common in the earth's crust. Chromium is also used in many industrial processes, including electroplating, wood treatment, paints, and cooling tower treatment for corrosion control. The two most common species of chromium are chromium III, an essential dietary nutrient, and chromium VI, which can be toxic. According to USEPA, background levels of chromium in US waters average 1 ppb, and drinking water averages 0.1 ppb to 35 ppb. A USEPA survey of more than 3,800 US water taps found average chromium levels of 0.4 ppb to 8 ppb, with varying amounts of chromium present. USEPA has established an MCL of 100 ppb for total chromium. Although chromium VI is a human carcinogen when inhaled, scientific consensus has not been reached on health effects from ingestion.

The subject of recent regulatory focus, arsenic is a naturally occurring element that is present in both groundwater and surface water. It is the twentieth most common element in the earth's crust (at average concentrations ranging from 1.5 to 5.0 mg/kg), and the twelfth most common element in the human body. Arsenic can be naturally introduced to groundwater and surface water through erosion, dissolution, and weathering processes. Anthropogenic sources of arsenic include lumber, agricultural practices, and general industry. Although concentrations of regulatory concern may be found in surface waters, arsenic is generally considered to be a groundwater issue. The toxicity of arsenic depends

on its chemical form and the route and duration of exposure. Arsenic can produce both acute and chronic noncarcinogenic effects and is considered a carcinogen. Amid widespread controversy, the current MCL is 10 µg/L.

Radionuclides. Radionuclides are elements that spontaneously undergo radioactive decay and release energy in the process. Radionuclides include both man-made and naturally occurring isotopes. Several MCLs exist for radionuclides. For example, strontium-90 is a man-made radioactive isotope derived from fission products of nuclear reactor fuels and is present in fallout from nuclear bombs. Strontium-90 has a variety of uses, including industrial thickness gauges, static charge elimination, eye disease treatments, and cigarette density control. Uranium, a naturally occurring radioactive element, is used in nuclear reactors and in the production of nuclear weapons.

Radon-222 (radon) is a radioactive element generated naturally as a gas in the earth that dissolves in groundwater. It volatilizes during showers, bathing, and other activities, such as washing clothes. Radon spontaneously decays to radioactive daughter products, and, in the process, changes from a gas to an ultrafine solid. Radon can be inhaled as well as ingested. Several studies have found a direct link between radon and human lung cancer.

Organic Groups

Volatile organic compounds (VOCs). VOCs have had widespread commercial and industrial use over the past 30 years. Industrial parts-cleaning and dry cleaning operations are the top two users of VOCs, followed by manufacturers of chemical intermediates, electronics, pharmaceuticals, and textiles. Facilities using VOCs range from small dry cleaners to major aerospace and defense industries. Common release sources of VOCs include drains, pipelines, and discharges diverted to soil or aquifers, and leaking underground storage tanks (LUST). VOC disposal and subsequent movement through landfills can increase the mobility of other toxic chemicals, all of which are ultimately reflected in the leachate contamination of groundwater.

Common solvent usage has included

- trichloroethylene (TCE) for industrial parts-cleaning
- tetrachloroethylene (PCE) for dry cleaning
- carbon tetrachloride (CCl₄), formerly used for dry cleaning and fire extinguishers
- 1,2-dichloroethane (DCA) in soaps and organic synthesis
- 1,1,2,2-tetrachlorethane for paint removers and in bleach manufacturing

The physical properties and unreactive nature of VOCs that make them so useful also helps make them persistent and mobile in groundwater. Their general toxicity to living organisms makes some VOCs resistant to biodegradation in the subsurface and a health issue for municipal water supplies (Montgomery 1996).

Methyl tertiary butyl ether (MTBE) is a fuel additive first introduced in the 1970s as an anti-knock compound when lead was phased out of gasoline. In the 1990s, it was added to reformulated gasoline as an oxygenate to reduce smog production. MTBE has been detected in rain, stormwater runoff, surface reservoirs, rivers, and groundwater. MTBE is highly soluble in water and does not readily degrade and is mobile and persistent in groundwater.

Currently, the USEPA classifies MTBE as a possible human carcinogen and has set a draft health advisory level of 70 µg/L. Additional human health effects studies are needed. However, MTBE can cause taste and odor problems at concentrations at approximately one-half this draft standard. Because it has a lower volatility, MTBE will likely be expensive to remove. Sources of MTBE in groundwater include leaking underground and aboveground fuel tanks, pipelines and associated booster stations, refineries, and spills. Additional sources that may impact groundwater resources include surface water recreational activities using 2-cycle engines.

Table 8-3 Regulated pesticides detected in groundwater

Pesticides	Type	Additional Uses/Comments
Atrazine	Herbicide	Plant growth regulator; used for highway weed control
Bentazon	Herbicide	Food crops
Chlordane	Insecticide	Fumigant
2,4-D	Herbicide	Defoliant; agriculture and pasture weed killer; fruit drop control
Dibromochloropropane	Nematocide	Soil fumigant
Endrin	Insecticide	Banned US use and manufacture
Heptachlor	Insecticide	Banned except for termite control
Heptachlor epoxide	Insecticide	Heptachlor and chlordane degradation product
Lindane	Insecticide	Livestock, crops, lumber
Methoxychlor	Insecticide	Acaricide: livestock, dairy farms, food crops
Simazine	Herbicide	Algaecide: agriculture, aquatic sites
Silvex	Herbicide	Banned plant growth regulator
Toxaphene	Insecticide	Not recommended for dairy activities

Pesticides. Pesticides are substances used to destroy or inhibit the action of plants or animal pests, and include insecticides, herbicides, rodenticides, and nematocides. They are associated with irrigated agriculture, dairy, and livestock activities. Virtually all are toxic to humans to some degree and they vary in biodegradability. Table 8-3 lists some of the regulated pesticides that have been detected in groundwater (Anderson 1990; USEPA 1990).

Trihalomethanes and HAAs. Groundwaters with significant organic content present treatment concerns because they contain trihalomethanes (THMs) and haloacetic acids (HAAs). Both form as a result of the reaction of chlorine with the organics. THMs have long been a suspected carcinogen and have been regulated at a total of 80 ppb. THMs and HAAs are normally an issue in surficial aquifer systems that are recharged by lakes or swamps. The Biscayne aquifer in southeast Florida, which underlies the Everglades is an example. As regulated carcinogens, THMs get the most focus. The THMs include:

- Chloroform
- Bromoform
- Dichlorobromomethane
- Dibromochloromethane

Chloramines solutions are suggested to retard the speed of the reaction with organics.

Nitrosamines. Nitrosamines are an emerging organic contaminant of concern throughout North America and have been found in polluted air and water (Bolton 2000). The major concern has been the occurrence of N-nitrosodimethylamine (NDMA) in potable water systems, first noted in California in 1998, but found throughout the United States and Canada at levels significantly higher than in the past (Yoo et al. 2000). Industrial contamination was initially investigated as an NDMA source in Canada, the widespread amount of NDMA suggested formation in the drinking water treatment process (Andrews and Taguchi 2000). Chlorination appears to be a causal agent.

NDMA is not currently regulated under USEPA drinking water rules. NDMA is classified as a Class I carcinogen in Canada, and a Class B2 probable human carcinogen in the United States. The compound has been known to cause carcinomas and tumors, primarily in the liver, kidney, and lungs (Andrews and Taguchi 2000). Because of NDMA's carcinogenicity, the Ontario Drinking Water Objective has been set at 9 ng/L, based on a

5×10^{-6} risk factor estimated by the USEPA (Andrews and Taguchi 2000). In California, the original action level was for NDMA at 2 ng/L based on a 10^{-6} lifetime cancer risk developed by the state, similar to the federal MCLs (CDHS 2000). However, the state action level was changed to 20 ng/L to allow utilities to study the problem because many sites sampled exceeded the 2 ng/L action level (Davis et al. 2000). The target set by USEPA for an estimated 10^{-6} risk level is 0.7 ng/L (CDHS 2000). This risk was assessed assuming an average ingestion of two liters per day for 70 years (Kruger 2000).

Pharmaceutically active substances. Chemicals, whether derived from pharmaceuticals, industrial emissions, or natural sources that interfere with endocrine systems of humans and wildlife are termed *endocrine disruptors*, and those that elicit a pharmaceutical response in humans are termed *pharmaceutically active substances* (PASs). Research has identified more than 60 PASs that impact the endocrine system of animals and humans in nanograms per liter or lower concentrations in the ecosystem. It has been estimated that 70 percent of pharmaceuticals consumed pass through the body unchanged.

Endocrine chemicals are used by organisms to regulate important metabolic activities, such as ion balance, reproduction, basal metabolism, and fight or flight responses through changes in hormones secreted by the thyroid, parathyroid, pituitary, adrenal, sex, and other glands. Because endocrine systems are interconnected, effects on one will affect others as well.

Disruptive effects of endocrine disruptors in the environment have been observed. While both natural and synthetic chemicals may have disrupting effects, most observations involve species feminization and have been attributed to estrogenic compounds found in wastewater effluents (Lutz and Kloas 1999). The reverse also occasionally occurs, as in North Florida, where wastewater effluent from a paper mill is suspected in the masculinization of fish through the development of androgenic compounds in the process (Raloff 2001). In both cases, the sex change effect results in radically reduced resident fish populations, sexually shifted remaining populations, and potential loss of sustainability of the resident population. Also in Florida, alligator populations have been found to have greatly reduced fertility, traced to a feminization and lack of development of reproductive organs in the male (Guillette et al. 1994). Nationally, many species have reportedly been affected (Colburn et al. 1997).

There are many potential sources of endocrine disruptor chemicals (EDCs). Wastewater is an obvious source for industrial pollutants and pharmaceutical residues from people. Industrial processes include metals and synthetic organic compounds. However, often overlooked is the extensive use of hormones (estrogenic ones) and antibiotics in the agricultural industry. Seventy percent of antibiotics are used in agriculture, and agriculture is generally upstream of potable water supplies.

Until recently, the problem of PASs in the environment was not noticed because of the low concentrations and difficulty in tracing the compounds. Tracing drug residues is problematic because many potential endocrine disrupting chemicals have little in common structurally or in terms of chemical properties (Depledge and Billingham 1999). In addition, lists of active ingredients in pharmaceutical products are not often made available because of patent limitations, hindering the development of spectral signatures needed for analysis by gas chromatography-mass spectroscopy (Daughton and Ternes 1999). Furthermore, current effluent toxicity screening tests are not designed to detect endocrine disrupting and other effects of PASs, the effects of chronic exposure, or prenatal effects realized in offspring.

Limited research has been conducted on the eco-toxicity of PASs, and subtle changes in the behavior and development of aquatic organisms may be the greatest concern. Pharmaceutically active substances and their ecological effects can be categorized (Daughton and Ternes 1999; Hirsch et al. 1999; Raloff 2001; Buser 1998; Ternes 1998) as shown in Table 8-4.

Table 8-4 Summary of pharmaceutically active substance occurrence in wastewater effluent and associated surface waters

	Substance	Uses	Concentration	Impacts
1	Estrogenic compounds	Contraceptive	1–5 µg/L	Feminization
2	Steroids (nonestrogens like androgen, testosterone, etc.)	Muscle development, various	Above 1 µg/L	Masculinization
3	Antibiotics	Reduce bacterial infection	Varies	Resistant pathogens
4	Blood lipid regulators	Cholesterol control	To 0.165 µg/L	Unknown
5	Nonlipid analgesics	Anti-inflammatory	0.5–1 µg/L	Unknown
6	Beta blockers		0.2 µg/L	Stimulate reproduction
7	Antidepressants	Increase serotonin, control behavior (Prozac, Ritalin)	Varies	Stimulate reproduction
8	Antiepileptics	Epilepsy control	To 6.3 µg/L	Unknown
9	Antineoplastics	Chemotherapy	0.017 µg/L	Toxicity, birth defects
10	Impotence drugs	Erectile dysfunction, blood stimulant	Unknown	Unknown
11	Retinoids	Skin diseases, anti-aging, cancer	Unknown	Birth deformities
12	Contrast media chemicals	X-rays, CAT scans, diagnostics	15 µg/L	None
13	Fragrances and musks	Perfumes, colognes	To 0.4 µg/L	Toxicity
14	Preservatives	Antimicrobial	Unknown	Feminization
15	Disinfectants	Bacteriocides	0.05–0.15 µg/L	
16	Herbal remedies	Various	Varies	Various
17	Sunscreens	Protect skin from UV light	Unknown	Unknown

Secondary wastewater treatment plants are designed principally to remove the oxygen demand of influent wastewater, through the degradative action of a series of resident microorganisms. Wastewater facilities that have received PASs in the influent for years may support resident organisms that have adapted to the metabolization of PASs. However, marketed pharmaceuticals evolve continuously, and therefore may escape treatment in typical biological reactors. In addition, PAS concentrations may be below that needed to initiate the enzyme affinity of the organisms (Daughton and Ternes 1999).

Sources of Chemical Contamination

Potential contaminants are generated by virtually all of industrial, agricultural, urban, and rural activities. The principal sources of contaminating substances are shown in Table 8-5.

Contaminants may enter groundwater reservoirs by intent and design, such as deliberate placement in the subsurface through a waste-injection well. Or, contaminants may enter a groundwater system inadvertently, for example, by leakage from a ruptured pipeline, as leachate from an inadequately sealed landfill, or as a result of agricultural fertilizer application.

Figure 8-1 illustrates the downward movement of a contaminant from a land surface source (in this example, a waste lagoon), through the zone of aeration (the zone of rock and soil above the water table, it is unsaturated with water), and then into the aquifer. As illustrated, the contaminating liquid migrates downward and laterally into the aquifer. The recharge mound built up beneath the source of the contaminant may propel some of the liquid in an upward direction (to the left in the illustration) for relatively short distances, but the dominant direction of movement for contaminant liquids with density similar to that of the groundwater is downward in the direction of general groundwater flow, indicated by the direction of slope of the old water table (to the right in the illustration).

Table 8-5 Major sources of groundwater contamination

Point Sources	Non-Point Sources
Landfills	Agriculture
Superfund-type sites	Dairies and feedlots
LUST	Seawater intrusion
Wastewater plants	Urban run-off
Oil production and refining facilities	Oil, sewer, and other pipeline networks
Industrial and manufacturing facilities	Oilfield brine injection
Septic tanks	Seawater intrusion
Spills and accidents	Acid-mine drainage

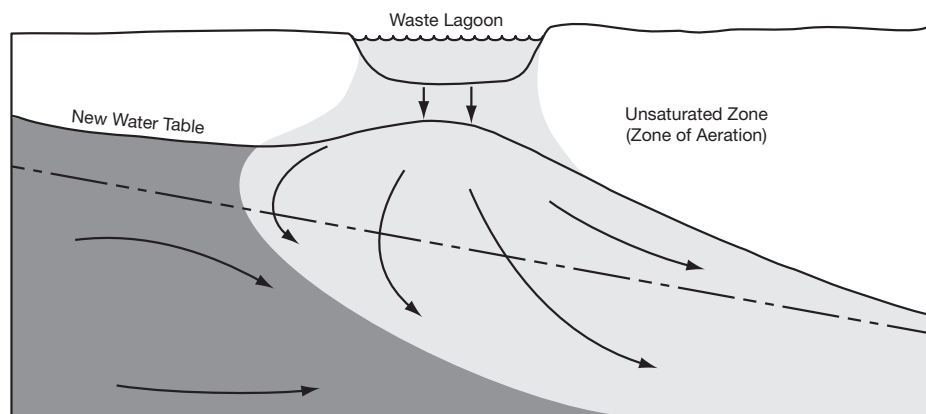
**Figure 8-1 Flow of contamination from a ponded surface source into an aquifer**

The relative densities of incoming fluids and of the receiving water in the aquifer influence the pattern of contaminant movement. High-density organics, such as chloroform, dichloroethane, and tetrachloroethylene, tend to “sink” to the lower part of the aquifer and are commonly called *dense nonaqueous phase liquids* (D-NAPLs). Comparatively, fluids that are less dense than water, such as gasoline and oil, tend to “float” on the groundwater and are called *light nonaqueous phase liquids* (L-NAPLs).

REFERENCES

- Akin, E.W. 1982. A Review of Infective Dose Data for Enteroviruses and Other Enteric Micro-organisms in the Human Species. *Microbial Health Consideration of Soil Disposal of Domestic Wastewaters*. Conference Proceedings: May 11–12, 1982. Norman, Okla.: University of Oklahoma.
- Anderson, L. 1990. Groundwater Quality, A Regional Survey of Groundwater Quality in the Metropolitan Water District Service Area. Report No. 991. Los Angeles, Calif.: Metropolitan Water District of Southern California.
- Andrews, S.A., and V.Y. Taguchi. 2000. NDMA—Canadian Issues. In *Proc. of the Water Quality Technical Conference*. Denver, Colo.: AWWA.
- Block, J.C. 1989. *Viruses in Water Supplies—Detection and Identification*. New York, N.Y.: VCH Press.
- Bloetscher, F., G.M. Witt, A.E. Dodd, and C.P. Dodd. 1998. Prevention of Biofouling in Membrane Water Treatment Plants. In *Proc. of the AWWA Annual Conference and Exposition*. Denver, Colo.: AWWA.

- Bloetscher, F., G.M. Witt, A.E. Dodd, and C.P. Dodd. 1996. Well Plugging Problems: Case Studies in Collier County, the City of Venice, and the City of Hollywood, Florida. In *Proc. of the American Water Works Association Annual Conference*. Denver, Colo.: AWWA.
- Bolton, J.R., and N.I. Nihaela. 2000. UV Photodegradation as a Treatment Technology for N-Nitrosodimethylamine (NDMA). In *Proc. of the Water Quality Technical Conference*. Denver, Colo.: AWWA.
- Bouwer, H. 1991. The Role of Groundwater Recharge in the Treatment and Storage of Wastewater for Reuse. *Water Science and Technology*, 24(9):259–302.
- Chapelle, F.H. 1993. *Groundwater Microbiology and Geochemistry*. New York, N.Y.: John Wiley and Sons.
- Colburn, T., D. Dumanosui, and J.P. Myers. 1997. *Our Stolen Future*. New York, N.Y.: Plume.
- Daughton, C.G., and T.A. Ternes. 1999. Pharmaceuticals and Personal Care Products in the Environment: Agents of Subtle Change? *Environmental Health Perspectives*, 107(Suppl. 6):907–938.
- Davis, M.K., S.E. Barrett, C.J. Hwang, Y. Gou, and S. Liang. 2000. N-Nitrosodimethylamine (NDMA) in Surface Water. In *Proc. of the Water Quality Technical Conference*. Denver, Colo.: AWWA.
- Depledge, M.H., and Z. Billingham. 1999. Ecological Significance of Endocrine Disruption in Marine Invertebrates. *Marine Pollution Bulletin*, 39(1–12):32–38.
- Durfor, C.N., and E. Becker. 1964. Public Water Supplies of the 100 Largest Cities in the United States. US Geological Survey Water Supply Paper 1812. Denver, Colo.: USGS.
- Feachem, R., H. Garelick, and J. Slade. 1981. Enteroviruses in the Environment. *Tropical Diseases Bulletin*, 28(3):185–230.
- Fergen, R.E. 1995–1997. Unpublished notes from City of Hollywood chlorine decay study.
- Gerba, C.P. 1999. Virus Survival and Transport in Groundwater. *Jour. Industrial Microbiology and Biotech.*, 22:535–539.
- Gerba, C.P., and G. Bitton. 1984. *Groundwater Pollution and Microbiology*. New York, N.Y.: John Wiley and Sons.
- Gloria, M.B., J.F. Barbour, and R.A. Scanlan. 1997a. N-Nitrosodimethylamine in Brazilian, US Domestic, and US Imported Beers. *Jour. Agric. Food Chem.*, 45: 814.
- Gloria, M.B., J.F. Barbour, and R.A. Scanlan. 1997b. Volatile Nitrosamines in Fried Bacon. *Jour. Agric. Food Chem.*, 45: 1816.
- Hurst, C.J. 1996. *Modeling Disease Transmission and Its Prevention by Disinfection*. Cambridge, UK: Cambridge University Press.
- Kruger, D., and W. Gedney. 2000. Case Studies of N-Nitrosodimethylamine in Groundwater Supplies. In *Proc. of the Water Quality Technical Conference*. Denver, Colo.: AWWA.
- Lemonick, M.D. 2000. Teens Before Their Time. *Time Magazine*, October 30:67–74.
- Liang, S.M., J.H. Joon, M.K. Davis, J.F. Green, and D. Remer. 2000. Treatment of N-Nitrosodimethylamine (NDMA) by Pulsed-Ultraviolet Irradiation and Pulsed-UV/Hydrogen Peroxide Processes. In *Proc. of the Water Quality Technical Conference*. Denver, Colo.: AWWA.
- Lister, P.D., D.J. Wolter, and N.D. Hanson. 2009. Antibacterial-Resistant *Pseudomonas aeruginosa*: Clinical Impact and Complex Regulation of Chromosomally Encoded Resistance Mechanisms. *Clin. Microbiol. Rev.*, October 2009: 22(4).
- Loret, J.F., and G. Greub G. 2010. Free-living Amoebae: Biological By-passes in Water Treatment. *Int. Jour. Hyg. Environ. Health.*, June 213(3):167–175.
- Loret, J.F., M. Jousset, S. Robert, G. Saucedo, F. Ribas, V. Thomas, and G. Greub. 2008. Amoebae-resisting Bacteria in Drinking Water: Risk Assessment and Management. *Water Sci. Technol.*, 58(3):571–577.
- Lutz, I., and W. Kloas. 1999. Amphibians as a Model to Study Endocrine Disruptors: I. Environmental Pollution and Estrogen Receptor Binding. *The Science of the Total Environment.*, 225:49–57.
- Montgomery, J.H. 1996. *Groundwater Chemicals Desk Reference*. New York, N.Y.: Lewis Publishers.
- Mumma, R.O. 1991. National Survey of Elements and Other Constituents in Municipal Sludge. *Arch. Env. Contaminant Toxicology*, 13:1984.
- Raloff, J. 2001. Macho Water: Some River Pollution Spawns Body-altering Steroids. *Science News*, January 6, 159:8–10.
- Rose, J.B., and R.P. Carnahan. 1992. *Pathogen Removal by Full Scale Wastewater Treatment*. Tampa, Fla.: University of South Florida.
- Sellword, J., and J.V. Dadswell. 1992. Human Viruses and Water. *Current Topics in Virology*. Cambridge, UK: Cambridge Press.

- Snyder, S.A., T.L. Keith, D.A. Verbrugge, E.M. Snyder, T.S. Gross, K. Kannan, and J.P. Giesy. 1999. Analytical Methods for Detection of Selected Estrogenic Compounds in Aqueous Mixtures. *Environmental Sci. and Tech.*, 33:2814–2820.
- US Environmental Protection Agency (USEPA). Ninth Report on Carcinogens, date unknown. Washington, D.C.: USEPA.
- USEPA. 1990. *Pesticide Fact Handbook*, Vol. 1 and 2. Park Ridge, N.J.: Noyes Data Corp.
- www.dhs.ca.gov/ps/ddwem/chemicals/NDMA/NDMAinde. (Californian Department of Health Services Web Site on NDMA as of September 7, 2000.)
- Yates, M.V., C.P. Gerba, and L.M. Kelley. 1985. Virus Resistance in Groundwater. *Applied and Environmental Microbio.*, 49(4):778–781.
- Yates, M.V., S.R. Yates, J.M. Wagner, and C.P. Gerba, 1987. Modeling Virus Survival and Transport in the Sub-surface. *Jour. of Contaminant Hydrology*, 1(1987):329–345.
- Yoder, J.S., B.A. Eddy, G.S. Visvesvara, L. Capewell, and M.J. Beach. 2010. The Epidemiology of Primary Amoebic Meningoencephalitis in the USA, 1962–2008. *Epidemiol. Infect.*, 138:968–975.
- Yoo, L.J., S. Fitzsimmons, and Y. Shen. 2000. Determination of N-Nitrosodimethylamine at Part-per-trillion Levels Using Positive Chemical Ionization from Aqueous Samples. In *Proc. of the Water Quality Technical Conference*. Denver, Colo.: AWWA.

Groundwater Treatment

This chapter provides an overview of common treatment techniques applied to groundwater. While groundwater generally requires less treatment than surface water, there are many available techniques including aeration, oxidation, softening and ion exchange, filtration, adsorption and absorption, corrosion control, disinfection, and fluoridation. When used in combination to achieve treatment goals, the interactions and effects of unit processes must be carefully considered. The processes required for both surface water and groundwater treatment are dependent on the constituents in the source water. Unlike surface water, groundwater generally does not contain organics or biological constituents unless it is under the influence of wastewater streams, in which case appropriate processes are available. For process flow diagrams and more discussion, refer to Bloetscher 2011.

AERATION

Aeration mixes water with air to transfer gas from the water to the air. Aeration is often employed to

- remove objectionable dissolved gases such as hydrogen sulfide and carbon dioxide
- remove certain volatile organic compounds (VOCs)
- oxidize reduced constituents in the water such as iron and manganese (see oxidation)

There are several precautions to take into account when considering aeration. Aeration of water with significant amounts of hydrogen sulfide can create odor problems and a highly corrosive environment for treatment plants and equipment. The introduction

of air into water containing microbiological populations can increase biological activity, potentially affecting downstream water quality. Aeration should not precede membrane filtration.

Methods of Aeration

The methods commonly used to mix water and air are presented in the following text.

Natural draft aeration. Natural draft aeration uses a device open to the atmosphere. Water enters the top, falls in or around trays, and is collected at the bottom. The turbulence and mixing of the cascading water provides gas transfer (see Figure 9-1).

Forced or induced draft aeration. Forced or induced draft aeration uses a device similar to the natural draft aerator but is equipped with a blower. The blower forces air from the bottom of the aerator out the top. This counter-current effect provides a greater level of gas transfer than the natural draft aerator and a higher “air to water ratio.”

Packed-tower aeration. The packed-tower aerator, also known as an *air stripper*, uses a column filled with a packing material typically made of plastic or ceramic. Like the other devices, the water is distributed at the top and allowed to flow to the bottom for collection. At the same time, a counter-current movement of air is provided. Because of its design, the packed-tower aerator can achieve high levels of efficient mixing and transfer and is typically used for treating VOCs. In many cases, the off-gas containing the VOCs is captured for further treatment (see Figure 9-2).

Diffused aeration. Diffused aeration mixes air with water in an open basin or tank. Air headers at the bottom of the basins produce a stream of upward flowing air bubbles for direct gas transfer and mixing. Mechanical agitation and mixing is also used.



Figure 9-1 Natural draft aeration system



Figure 9-2 Packed-tower aeration

OXIDATION

In oxidation, one or more reactants lose or donate electrons (oxidize) and one or more reactants are reduced (gain or accept electrons). Oxidation reactions are very common for the treatment and disinfection of groundwater.

For example, soluble iron (Fe^{+2}) and manganese (Mn^{+2}) generally oxidize to ferric (Fe^{+3}) and manganic (Mn^{+4}) forms, which are insoluble and precipitate. Oxidation can remove color, tastes, and odors to varying degrees. Common chemical additives capable of providing oxidation include ozone (O_3), permanganate (MnO_4^-) and chlorine (Cl^-). Although aeration can provide a level of oxidation, its effect is weak compared with direct application of the chemical oxidants.

Chlorine and Chlorine Compounds

Aqueous chlorine is one of the most effective chemical oxidants for use in manganese oxidation, carbon removal, and control of taste and odors. Unfortunately, free residual chlorine may combine with organic compounds to create trihalomethanes (THMs) and other by-products. Chlorine can be used for oxidation (see Figure 9-3).



Figure 9-3 Chlorine cylinders

Potassium Permanganate

Potassium permanganate (KMnO_4) can oxidize most organic and many inorganic pollutants in water. Thermodynamic reactions form manganese dioxide (MnO_2), lending the remaining oxygen pair for use to oxidize iron and other contaminants.

Potassium permanganate is used to oxidate iron, manganese, cyanide, and phenols. It is used for taste and odor control, and for color removal. Often, potassium permanganate is injected into the water stream before a contact or oxidation tank. The tank provides sufficient detention time for the thermodynamic reactions to occur. The potassium permanganate dosage must be carefully determined and controlled, or the treated water will contain an excess of manganese and be pinkish-purple in color.

Ozone

In aqueous systems, ozone (O_3) reacts directly with contaminants, or indirectly, when ozone decomposes to form the hydroxyl radical. The indirect process is advanced oxidation.

Treatment applications. Ozone is a powerful oxidant often used as pretreatment or in an intermediate treatment process. Ozone is useful for treating taste, odor, and color compounds because the causative substances in natural waters contain ozone-sensitive functional groups or unsaturated bonds. The organic compounds may not be completely oxidized and may change in molecular structure, often requiring further treatment. Ozonation by-products are discussed in the disinfection section of this chapter.

Ozone oxidizes synthetic organic chemicals (SOCs), an application favoring the high selectivity of molecular ozone. Ozone is most useful as an oxidant of phenolic pollutants and some pesticides with vulnerable functional groups. Advanced oxidative processes may be necessary to oxidize other SOC.

Advanced Oxidation

Advanced oxidation processes (see Figure 9-4) generate an oxidizing agent called the hydroxyl (OH^-) radical, which is extremely reactive because it contains a single, unpaired electron. Unlike molecular ozone, the hydroxyl radical is not selective as an oxidizing agent. Advanced oxidation most commonly involves the use of three treatment processes: hydrogen peroxide and ozone, UV light and ozone, and UV light and hydrogen peroxide. The UV light (see Figure 9-5) or hydrogen peroxide acts to encourage ozone decomposition to the hydroxyl radical in quantities sufficient to treat otherwise ozone-resistant contaminants.

Advanced oxidation has been used in treatment of taste and odor compounds, most commonly found in the middle of a treatment train. Typically, the ozone dosage required is low. Laboratory and pilot-plant studies have been conducted for the treatment of SOCs. Molecules that are refractory to molecular ozone, such as halogenated alkanes and alkenes, and some aromatics, such as benzenes, are reactive with the OH^- radical. Pilot-scale work indicates that advanced oxidation may be useful in removing THM precursors that are resistant to molecular ozone, such as certain ketones. As is the case with ozone, formation of bromate and assimilable organic compounds (AOCs) are a concern with advanced oxidation.

SOFTENING AND ION EXCHANGE

Hardness is caused by a high concentration of divalent metallic cations, mostly calcium (Ca^{2+}) and magnesium (Mg^{2+}), but also iron (Fe^{2+}), manganese (Mn^{2+}), and strontium (Sr^{2+}). Hardness in potable water increases the amount of soap needed to produce a foam or lather and causes scale in hot water pipes, heaters, and boilers. Treatment for softening and iron and manganese removal are related.

Hardness in drinking water is derived largely from contact with soil and rock formations. In general, hard waters originate in areas where the topsoil is thick and limestone formations are present. In other geologic formations, such as granitic-based materials, the groundwater contains less calcium and magnesium but may still contain too much iron and manganese. Although not considered to be health hazards, iron and manganese can impart color to water and can stain laundry and plumbing fixtures (generating “red water” complaints). Iron and manganese can precipitate in pipes and fittings and can encourage bacterial slime growths in hot water pipes, heaters, and boilers.



Figure 9-4 Advanced oxidation process—hydrogen peroxide with UV light are typical processes



Figure 9-5 UV light system

Softening Treatment

Softening of hard water is usually accomplished by one of the following methods:

- Chemical precipitation with lime alone or lime and soda ash (lime–soda ash process)
- Sodium-cycle ion-exchange process
- Membrane processes

Membrane processes, while used for softening, are discussed at length in the last section of the chapter.

Lime–soda ash process. The lime–soda ash process can be used at ambient or elevated temperatures. Cold lime softening is one of the oldest methods of water treatment. Lime (calcium oxide—CaO) is added to the water. Typically lime is stored in a silo (lime is blown into the silo—see Figure 9-6) in dry form via a lime slaker, where it is mixed with water (Figure 9-7) and then mixed with the raw water in some form of lime softening unit (see Figure 9-8). It may also be added in combination with soda ash (sodium carbonate). The hot process is used primarily by industry for the treatment of medium-pressure boiler feedwater. The choice of treatment depends on the composition of the water to be treated and the degree of hardness reduction desired.

Temperature, retention time, and contact of previously formed precipitates with influent raw water and treatment chemicals will influence chemical efficiency and the finished water quality of the cold lime–soda ash softening process. A cold softener has the capability to produce calcium at 35 mg/L as CaCO₃, total alkalinity at 35 mg/L as CaCO₃, and to remove carbon dioxide.

The treated discharge from a lime or lime–soda ash process softener (either hot or cold) is saturated or supersaturated with calcium carbonate, making it scale-forming. Carbon dioxide (recarbonation) can stabilize the effluent. Acid is also used to convert carbonates to bicarbonates and render the water stable.

Ion-exchange process. Ion exchange is a chemical process that reversibly exchanges undesirable ions with alternative ions. In the sodium-cycle ion-exchange process, calcium and magnesium are exchanged for very soluble sodium ions. Historically, this softening process was called *sodium zeolite softening*, because natural (e.g., greensand or glauconite) or synthetic zeolite was used as ion exchange materials.

Although natural zeolites are still in use, modern ion-exchange materials consist of a matrix or hydrocarbon network such as polystyrene, which is co-polymerized with divinyl benzene (DVB). The matrix is converted to a strong-acid cation exchanger or to a strong-base anion exchanger, depending on the type of ionizable groups attached to the network. In softening by ion exchange, only strong-acid, cation-exchange resins operating in the sodium cycle are used as exchange material.

The ion-exchange softening process consists of passing the hard water, usually under pressure, through a tank containing the cation-exchange resin in the sodium form (see Figure 9-9). In the tank, calcium and magnesium ions are replaced with the more soluble sodium ions, as are other dissolved ions such as iron, manganese, barium, strontium, and zinc. Ion exchange is also applied to removal of anions such as nitrates. In this case, the anions replace OH^- ions. All ion exchange filters must be backwashed and regenerated on a regular basis.



Figure 9-6 Typical silo for dry lime (lime is blown into the silo)



Figure 9-7 Slaker system



Figure 9-8 Mixed with the raw water in some form of lime softening unit



Figure 9-9 Ion exchange system

Iron and Manganese Treatment Methods

Ion exchange. Greensand continues to be a popular ion exchange media for the removal of iron and manganese. The process by which greensand removes these metals has been described both as ion exchange and adsorption. Generally, permanganate is added as a pretreatment to oxidize the metals and also to regenerate the greensand. Chlorine is also used as a pretreatment, particularly if bacterial fouling of the filter media is a problem.

Oxidation and filtration. If both the iron and manganese can be fully oxidized, the precipitates can be removed by filtration. However, manganese is more difficult to oxidize than iron, and complete oxidation requires adequate oxidation contact time. A typical treatment system includes increasing the pH prior to filtration to reduce the solubility of the metals.

Sequestering. Sequestering is a strategy for controlling iron and manganese by maintaining the metals in solution. Instead of removal, the metals are made complex by reacting with a sequestering agent to prevent their oxidation and precipitation. Phosphate or silicate compounds are often used for this purpose. The success of sequestering is site specific and is generally limited to waters with a total concentration of iron and manganese below 1 mg/L.

FILTRATION

Filtration has traditionally been used to remove turbidity from surface water supplies. The following paragraphs discuss two common filtration methods often used in groundwater treatment. They are granular filtration and cake filters. While membranes are also used as a filtration method, they can be considered alternative technology and will be discussed at length later in this chapter.

Granular Filtration

Granular filters remove solids from water using fine, porous media such as sand, anthracite coal, magnetite, garnet sand, and coconut shells. Granular filtration (Figure 9-10) is often preceded by rapid mix, coagulation, and flocculation to create suspended and colloidal particles that can be filtered. Groundwater systems may use pressure filters (Figure 9-11) to achieve greater economic benefits over the open, gravity designs typically employed for treatment of surface waters. Granular filters must be backwashed regularly (Figure 9-12).

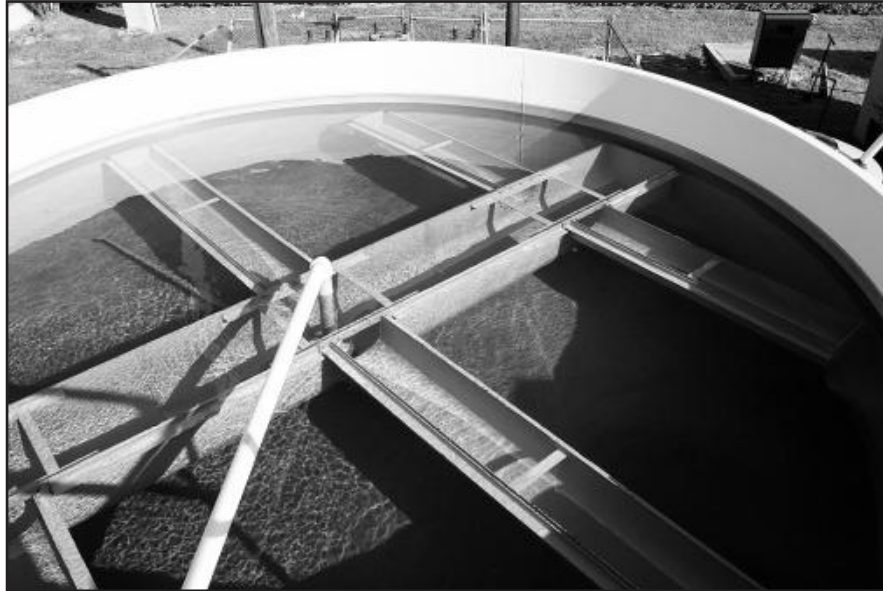

Figure 9-10 Granular filtration



Figure 9-11 Pressure filters



Figure 9-12 Example of filter being backwashed. Backwashing needs to occur regularly but the backwash should be recaptured to improve water use efficiency.

Cake Filters

Cake filters, also known as *precoat filters*, deposit particles that become incorporated in the filter media, which increases in depth. The best known type is diatomaceous earth (DE) filters. DE is a natural occurring material consisting of the microscopic remnants of the discarded frustules of diatoms.

DE filters may be closed, pressure types, or open, suction types. In either case, a septum (a porous material) is “precoated” with a layer of DE at the beginning of a filter run. During the filter run, a “body feed” of DE is continuously fed with the influent water to build up the filter bed or cake. At the end of a filter run, the filter is backwashed and the filter cake with the imbedded particles is sloughed off and discharged to waste.

ADSORPTION AND ABSORPTION

Adsorption is the collection of a substance onto the surface of another. This process is distinguished from absorption, which is the penetration of the substance into the solid. Both processes remove soluble contaminants; when occurring together, the combined process is referred to as *sorption*. The most commonly used media is activated carbon. Media have a limited adsorption and absorption capacity. When exhausted, contaminants will breakthrough and possibly cause desorption (leaching of contaminants). A major operating cost is the periodic replacement of the media before its treatment capacity is reached.

Activated Carbon

Removal of impurities by activated carbon involves both absorption and adsorption; however, in practice the process is referred to as adsorption. Activated carbon is made from

the carbonization or heating of various materials such as wood, sawdust, fruit pits and coconut shells, coal, and petroleum-based residues. The solids are carbonized and then activated using hot air or steam-producing pores, which increases the effective surface area per unit mass of carbon. Powdered activated carbon (PAC) and granular activated carbon (GAC) are used in drinking water treatment.

Granular Activated Carbon

Granular activated carbon (GAC) is used in fixed beds either in pressure or open, gravity filters. GAC is often used to treat taste, odor, and color problems and is considered by USEPA to be the best available technology (BAT) for removal of many regulated VOCs and SOCs. GAC is also used for removal of radon-222 and disinfection by-products. Potential problems include breakthrough, desorption of contaminants, the effects of backwashing on GAC loss, and bacterial growth on the filter media. Spent GAC may be regenerated and reactivated.

Powdered Activated Carbon

Powdered activated carbon (PAC) differs from GAC by its smaller particle size and application. PAC is added as a dry powder or slurry prior to filtration. PAC is added only when needed, often to treat sporadic or seasonal taste and odor problems.

CORROSION CONTROL

Corrosion is the deterioration of metallic structures in contact with water, usually with loss of metal to solution. External pipeline corrosion is important; however, this discussion focuses on internal pipeline corrosion. Internal corrosion can result from metabolic (microbial) activity, chemical dissolution, or physical abrasion by excessive fluid velocities. Corrosion can affect both the structural capacity of the pipe and the quality of the water.

Corrosion typically causes rusting, pitting, and tuberculation of iron, copper, and lead water pipes, valves, and appurtenances. Metal is leached into the water. The severity of the problem depends on the chemical corrosivity of the water, biological activity, types of pipe materials, and other factors.

Water is considered chemically corrosive if

- pH, alkalinity, hardness, silicates, and phosphates are relatively low
- dissolved oxygen, chlorine residual, total dissolved solids (TDS) (or specific conductance), chlorides, sulfates, hydrogen sulfide, and carbon dioxide are relatively high

Several indexes express the degree of corrosivity of water. The most common corrosion index used in the water industry is the Langelier saturation index (LSI), also known as the *calcium carbonate saturation index*. The LSI is used to predict the degree of calcium carbonate saturation in water. It is measured using the difference between the actual pH and the hypothetical pH at saturation equilibrium. Plant operators use the LSI to determine the potential for issues related to corrosion and dissolution of lead and copper piping; however, the LSI can also be used for other water quality evaluations. Maintaining water quality above the calcium carbonate saturation is still considered to be the principal means of controlling corrosion in iron distribution piping. If a solution is supersaturated with respect to calcium carbonate, the pipe will be coated with an eggshell-like protective coating made up of deposited calcium carbonate. Equation 9-1 is the defining equation.

$$\text{LSI} = \text{pH}_a - \text{pH}_s \text{ (at } 25^\circ\text{C and TDS} < 500 \text{ mg/L)} \quad (\text{Eq. 9-1})$$

Where:

pH_a = the actual pH of the system

pH_s = the saturation pH for calcium carbonate precipitation

If the $LSI < 0$, $CaCO_3$ dissolves, which can also indicate that the water may be corrosive to steel if oxygen is present. The greater the deviation of pH_a from pH_s , the more pronounced the instability.

LSI	Interpretation
< 0	Undersaturated, corrosive
> 0	Oversaturated, scaling

In practice, water is considered to be potentially aggressive if it has an LSI of less than -1.5.

It should be noted that LSI can be misleading. Consider the following two cases:

Case 1: Because the protective scale formation is dependent on pH, bicarbonate ion, calcium carbonate, dissolved solids, and temperature, each may affect the water's corrosive tendencies independently. Soft, low-alkalinity waters with either low or excessively high pH are corrosive, even though this may not be predicted by the LSI. This is because insufficient amounts of calcium carbonate and alkalinity are available to form a protective scale.

Case 2: Waters with high pH values and sufficient hardness and alkalinity may also be corrosive, even if the LSI predicts the opposite. This is the result of calcium and magnesium complexes that cannot actively participate in the scale forming process. Analytical procedures do not distinguish between these complexes and available calcium and magnesium; therefore, the LSI value is not accurate in such situations.

Another index used to express the corrosivity of water is the Ryznar stability index (RSI). RSI uses the same calculations for pH_s and pH_a as the LSI, however, the interpretation is different. The defining equation is Eq. 9-2.

$$RSI = 2 (pH_s) - pH_a \quad (\text{Eq. 9-2})$$

Values for the RSI are interpreted as follows:

RSI	Interpretation
< 6.0	Scaling increases
> 7.0	Scaling may not occur
> 7.5-8	Probability of corrosion increases

The RSI value of water should be less than 10 for it to be considered to be stable and noncorrosive.

Lastly, the calcium carbonate precipitation potential (CCPP) index is another stability index, which uses more parameters to predict calcium carbonate precipitation. The CCPP index is more reliable, because it provides a *quantitative* measure of the calcium carbonate deficit (or excess of the water), giving a more accurate guide as to the likely extent of $CaCO_3$ precipitation.

The calculations are not as simple as the LSI or RSI. There are several software applications that can perform the analysis. There is also a graphical solution, such as the Caldwell-Lawrence diagram.

The CCPP index is interpreted as the following:

CCPP	Interpretation
> 0	Scaling
0 to -5	Passive
-5 to -10	Mildly dissolving
< -10	Dissolving

Although a number of indices have been developed, none has demonstrated the ability to *accurately* quantify or predict the corrosivity of water.

The following statements should be considered when assessing the corrosivity of water:

1. In general, softer waters are more corrosive than harder, scaling waters.
2. Materials such as galvanized steel, copper, brass, stainless steel, and concrete all have quite different corrosion or degradation mechanisms and a universal application of corrosivity can be quite misleading. Virtually all common materials corrode through a localized rather than general corrosion mechanism, i.e., there is a tendency to pit.
3. The use of various saturation indices such as LSI and CCPP can be particularly misleading. These are not corrosion indices and are incapable of predicting metallic corrosion rates. However, they do have some use as water treatment targets to ensure a reasonably stabilized, buffered supply that does not unduly affect cement-mortar linings on steel and cast-iron pipes.
4. Although low pH (acidic conditions) would seem to be a worst case for corrosion, high pH can be just as troublesome for some materials as copper and brass. For copper, this may be related to complex issues with microbiologically induced corrosion (MIC). High pH often reduces the effectiveness of disinfection that may promote MIC. For other materials, such as galvanized steel or aluminum alloys, high pH can increase the corrosivity quite significantly.
5. High levels of disinfectants such as chlorine or chloramines may negatively impact on the performance of some material, including some elastomers and plastics. Chloramines can be particularly aggressive to some elastomers. The normal levels of disinfectant associated with reticulation supplies generally have minimal impact on common pipe and plumbing materials. However, in some cases, the normal levels of disinfection can be beneficial in preventing MIC, particularly in copper.
6. Chlorides, in the range normally found in drinking waters, have relatively little effect on corrosion rates of most materials. The exception is stainless steel, where crevice corrosion can and does lead to significant corrosion if the design, grade and fabrication techniques are not properly considered. As a rule of thumb, grade 316 stainless steel should be used in waters with chloride levels above 200 mg/L, while higher-grade stainless steels should be used when chlorides are above 1,000 mg/L (Bloetscher et al. 2006).

Treatment

Strategies for reducing corrosivity generally include increasing the pH, increasing the alkalinity, or adding a corrosion inhibitor. Common chemical additives for increasing

the pH and alkalinity include lime, soda ash, sodium bicarbonate, caustic soda, and potassium hydroxide. Common corrosion inhibitors include silicates, orthophosphate, polyphosphate, and phosphate blends, which react with the pipe material to form a less soluble metal coating. This action is known as *passivation*. When adding silicates or phosphates, an adequate chlorine residual must be maintained because these compounds are nutrients that can stimulate microbiological activity and produce taste and odor complaints.

DISINFECTION

Disinfection is defined as the destruction of *pathogenic* microorganisms (as opposed to sterilization in which all living organisms are destroyed). Bacteria, viruses, protozoa, amoebic cysts, algae, and helminth (worms) are targeted organisms. Disinfection is most commonly achieved using chemical oxidizing agents such as chlorine, chlorine dioxide, chloramines, iodine, or ozone. Other methods include UV radiation and maintenance of an elevated pH.

Disinfection effectiveness depends on the sensitivity of targeted microorganisms, disinfection concentration, contact time, and other water quality characteristics. Bacteria are the most sensitive to disinfection, followed by viruses, protozoan spores, and bacteria spores. Some enteric viruses that lack sensitive enzyme systems are very resistant.

Traditionally, the presence of coliform bacteria has been used as an indicator of viruses and other microorganisms. However, this practice is under review following outbreaks of some enteric viruses and the protozoa *Cryptosporidium* without the presence of coliforms.

Chlorine

Chlorine is the most widely used disinfectant because it is effective at low concentrations, relatively inexpensive, and can form a residual. Chlorine can be applied as a gas or as hypochlorite. Hypochlorite salts are available in dry (calcium hypochlorite) or liquid (sodium hypochlorite) form. When mixed with water, chlorine forms hypochlorous acid (HOCl) and hydrochloric acid (HCl). The HOCl further disassociates to yield the hypochlorite ion (OCl⁻). Compared with OCl⁻, HOCl is more effective. Formation of the hypochlorite ion from HOCl is pH dependent. At pH 7, 80 percent of the chlorine exists as HOCl; at pH 8, 80 percent of the chlorine exists as the less effective OCl⁻. Effective chlorination requires careful attention to system pH.

Chlorine is a very reactive oxidizing agent and combines with ammonia, sulfites, metals, and organic material. Chlorine demand is the amount of chlorine that is used up in these extraneous reactions before it becomes free available chlorine for use as a disinfectant.

Chlorination reactions may produce by-products, including THMs and organic halides in waters that contain humics or other natural organic precursors. If by-product formation exceeds regulated limits, options include precursor removal or the use of alternative disinfectants.

Chloramines

Chloramines are compounds formed when chlorine reacts with ammonia that may be naturally present or intentionally added. Chloramines are less effective than HOCl and OCl⁻, and less effective against viruses than bacteria. The benefits of chloramine disinfection are a lower generation of chlorination by-products and a greater residual stability in the distribution system.

Chlorine Dioxide

Chlorine dioxide (ClO_2) has not been widely used as a disinfectant. Like chloramines, chlorine dioxide is not as effective a disinfectant as chlorine. However, chlorine dioxide does not react with ammonia or nitrogenous compounds nor does it react with precursors to produce THMs. Chlorine dioxide does produce two by-products, chlorite (ClO_2^-) and chlorate (ClO_3^-), which are candidates for future regulation. Chlorine dioxide has also been associated with odor generation in some homes with new carpeting.

Ozone

Most bacteria, including coliforms, are highly susceptible to ozone. Exceptions are the relatively resistant gram positive *bacillae* and *mycobacterium*. Viruses are generally more resistant than bacteria. Ozone is considered particularly effective for *Giardia lamblia* and *Cryptosporidium* cysts, which are relatively resistant to chlorine. Ozone does not produce a disinfection residual in the distribution system as does chlorine. *Escherichia coli* are so sensitive to ozone relative to other organisms that it is not a good indicator of the quality of water disinfected by ozone.

Ozone can oxidize large, organic macropollutants into smaller, more biodegradable compounds, producing an increased level of AOCs. AOCs can stimulate distribution system biological activity, including increased biofilm production. Ozonation produces bromate (a regulated substance) in waters with bromide ions. The ions react with natural organic matter to produce tribromomethane and bromoacetic acids.

FLUORIDATION

A fluoride concentration of up to 1 mg/L in drinking water is generally considered to reduce dental decay. Some groundwaters contain naturally high levels of fluoride and, in some cases, fluoride must be reduced to acceptable levels by ion exchange with activated alumina, lime softening, or coagulation.

Hydrofluosilicic acid (H_2SiF_6) is often used as an additive because it is purchased as a bulk liquid. Dry additives include sodium fluoride (NaF), calcium fluoride (CaF_2), ammonium silicofluoride (NH_4SiF_6), and sodium silicofluoride (Na_2SiF_6). The dry additives require a dry feeder (either gravimetric or volumetric) and saturation tank or mixing by hand.

MEMBRANES

Membranes are physical processes like filters but can remove particles down to molecular size. Membranes have increased in popularity for treating groundwater sources. There are two types of membranes commonly used with groundwater, depending on whether the water is fresh or brackish. For freshwater supplies, nanofiltration is the appropriate process. Nanofiltration membranes are the newest technology designed to lower hardness. Where water is naturally very hard and softening is not provided by the water system, customers often install softening units on their water service. Nanofiltration is a reverse osmosis process designed to remove hardness and metals from the water. These membranes operate at 90–150 psi. The option has been pursued extensively among south Florida communities because in addition to hardness removal, it removes the organics that occur naturally in the surficial groundwater. These organics can create issues with color and THMs in the finished water. Based on projects in Hollywood, Deerfield Beach, and Collier County, the co-location of a lime softening plant on the same site as a nanofiltration

plant was deemed an additional benefit because the combining of the two waters tends to reduce chemical use for both facilities.

Reverse osmosis membranes are used to remove salt (see Figure 9-13). Brackish groundwater is treated with low-pressure reverse osmosis membranes. The typical pressures are 200 psi to 300 psi. Salts, not organics, are the issue. Hardness remains a concern as well. However, disposal of concentrate is problematic, so larger facilities tend to pursue Class I injection wells to dispose of concentrate. Currently, reverse osmosis and nanofiltration systems productivity in municipal water treatment plants is typically maintained between 50 percent and 90 percent, as water recovery (Sethi et al. 2006), depending on raw water quality and system design.

Because the particles removed are so small, membrane plants usually have two filtering processes. Cartridge filtration is essential for removal of suspended particulates larger than 5 μm from the raw water. Once the raw water is chemically conditioned and suspended solids are removed by the cartridge filters, it is delivered to the feed pumps as “feedwater.” If there is sand or turbidity in the water, standard sand filters are commonly used as a pretreatment process in addition to cartridge filters.

A dedicated feed pump is normally used for supplying each skid. The feed pump increases the feedwater pressure prior to applying it to the membranes themselves. Figure 9-13 shows a typical membrane skid. The membranes are housed in the horizontal tubes, termed *vessels*, as shown in Figure 9-13. Figure 9-14 shows how the membranes work. One side is the clean water (permeate) while the other side retains the minerals (concentrate). Pressure pushes the raw water through the membrane’s very tiny holes.

Typical skids accommodate two or three stages of membranes. Each stage recycles the concentrated water from the previous stage—the more stages, the higher the recovery rate. The process recovery rate for nanofiltration (membrane softening) is 85 percent to 92 percent, while brackish reverse osmosis (saltwater removal) systems can produce only a 50 percent to 75 percent recovery, as compared to minimal losses in more traditional treatment regimes. The reduced recovery in the saltwater processes increases the quantity of raw water required to produce the same amount of permeate from one process skid, while producing a larger waste stream of concentrate, meaning that the concentrate disposal requirements are larger, and more raw water is needed to serve the same number of people. Disposal of the concentrate is a major concern with all membrane systems, as the ionic imbalance of the concentrate makes it acutely toxic to marine and freshwater organisms. As a result, surface discharge is normally difficult to permit.

A membrane cleaning/flushing system is required, which consists of cleaning and flushing solution tanks, 5- μm cartridge filters, and cleaning pumps. The cleaning pumps are constructed to handle high and low pH cleaning chemicals. The cleaning system must be designed to accommodate future needs when the system is expanded. If a membrane system is shutdown, a shutdown flush is required so that any raw water in the membrane elements is replaced with permeate water.

Designers, membrane manufacturers, and water treatment plant operators generally target the 50 percent to 90 percent water recovery range because of concerns related with: (1) efficiency limitations of current membranes and equipment; (2) concentrate management issues; (3) potential for increased or permanent fouling; (4) decrease in water quality; and (5) perceived potential cost increases due to more frequent membrane cleaning or replacement (Toro et al. 2010). Recovery has been limited in membrane processes because of concerns with equipment and membrane performance. Increases in recovery require increases in the driving force due to build-up in osmotic pressure, which implies higher concentration gradients and concentration polarization, which will increase wear on the membrane and the pumping equipment (Bloetscher et al. 2006; Sethi et al. 2006). Hence, materials and construction costs will increase, and operation and maintenance

costs will also be higher. In addition, as recovery increases, more intense pilot testing may be required to guarantee process reliability at full-scale, which also increases the cost (Lee et al. 2005). Higher costs are also associated with fouling or accumulation of dissolved solids on the membrane surface. Fouling typically reduces membrane life, increases energy consumption, increases maintenance costs associated with more frequent cleaning cycles, and necessitates more extensive pretreatment (Lin et al. 2005; Ng 2004; Chen and Seidel 2002; Vrijenhoek et al. 2001; Kilduff et al. 2000).



Source: Bloetscher 2011

Figure 9-13 Typical membrane skids

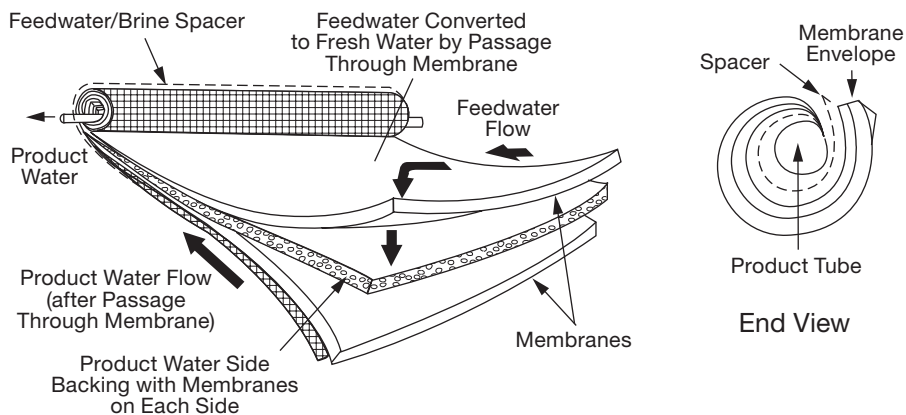

Source: WSO: Water Treatment 2010

Figure 9-14 How membranes work

REFERENCES

- American Water Works Association (AWWA). 2010. *WSO: Water Treatment*. Denver, Colo.: AWWA.
- Bloetscher, F. 2011. *Utility Management for Water and Wastewater Operators*. Denver, Colo.: American Water Works Association.
- Bloetscher, F., D.E. Meeroff, M.E. Wright, D. Yang, R. Rojas, J. Polar, M. Laas, B. Bieler, D. Sakura-Lemessy, S. Abdul, and C. Fiekle. 2006. Defining the concentrate disposal problem and identifying potential solutions. *Florida Water Resources Journal*, 58(3): 25–30.
- Chapman-Wilbert, M. 1993. *The Desalting and Water Treatment Membrane Manual: A Guide to Membranes for Municipal Water Treatment*. Technical Report R-93-15. Denver, Colo.: U.S. Department of the Interior, Bureau of Reclamation.
- Chen, J.C. and A. Seidel. 2002. Cost optimization of nanofiltration with fouling by natural organic matter. *Jour. of Environmental Engineering*, 128(10):967–973.
- Health Education Services. 1992. *Recommended Standards for Water Works*. Albany, N.Y.: Health Education Services.
- James M. Montgomery, Consulting Engineers, Inc. 1985. *Water Treatment Principles and Design*. New York: Wiley-Inter-Science.
- Kilduff, J.E., S. Mattaraj, J.P. Pieracci, and G. Belfort. 2000. Photochemical modification of poly(ethersulfone) and sulfonated poly(sulfone) nanofiltration membranes for control of fouling by natural organic matter. Conference on membrane in drinking and industrial water production, *Desalination Publication, L' Aquila, Italy*, 2:239–248.
- Lee, S., J. Cho, and M. Elimelech. 2005. A novel method for investigating the influence of feed water recovery on colloidal and NOM fouling of RO and NF membranes. *Environmental Engineering Science*, 22(4):496–509.
- Lin, C.J., S. Shirazi, and P. Rao. 2005. Mechanistic model for CaSO₄ fouling on nanofiltration membranes. *Jour. of Environmental Engineering*, 131(10):1387–1392.
- Ng, H.Y. 2004. RO membrane solute rejection behavior at the initial stage of colloidal fouling. *Desalination*, 174:211–217.
- Osmonics, Inc. 1991. *Pure Water Handbook*. Minnetonka, Minn.: Osmonics, Inc.
- Sawyer, C.N. and P.L. McCarty. 1978. *Chemistry for Environmental Engineering*. New York, N.Y.: McGraw-Hill Book Company.
- Sethi, S., S. Walker, J. Drewes, and P. Xu. 2006. Existing and emerging concentrate minimization and disposal practices for membrane systems. *Florida Water Resources Journal*, 58 (6): 38-48.
- Snoeyink, V.L. and D. Jenkins. 1980. *Water Chemistry*. New York, N.Y.: John Wiley & Sons.
- Toro, A., F. Bloetscher, and D.M. Meeroff. 2010. Concentrating the Concentrate—Pointing to Solutions for Concentrate Management. *IDA Journal*, 1(1): 39-51.
- US Environmental Protection Agency. Drinking Water Technology Branch, Drinking Water Standards Division, Office of Ground Water and Drinking Water. September 1992. *Lead and Copper Rule Guidance Manual*. EPA Contract No. 68-CO-0062. Washington, D.C.: Government Printing Office.
- Vrijenhoek, E.M., S. Hong, and M. Elimelech. 2001. Influence of membrane surface properties on initial rate of colloidal fouling of reverse osmosis and nanofiltration membranes. *Jour. of Membrane Science*, 188:115–128.

This page intentionally blank.

Record Keeping

As part of effective well field management, the proper operation of a groundwater system includes the gathering, compiling, and recording of a wide variety of data. Pumping data from production wells must be collected to compile an operating history of the wells. Such data are used to detect a loss of production efficiency and possibly the cause of a loss. The data are also used to schedule well maintenance at opportune times to avoid breakdowns. This data can also be used to evaluate the cost of water production and guide improvements to the physical system and to the operating methods.

Capacity declines occur in most water wells primarily due to gradual loss of efficiency within and immediately adjacent to the well screens. The main objective of any record-keeping program is to compile information that makes it possible to compare actual operating characteristics and conditions with original and calculated (theoretical) design performances. This historical data can also be helpful in assessing the cause of problems with the well and pumping system, and in directing design modifications for future wells to improve efficiencies and production capability.

The forms used for record keeping are not critically important. Records must be collected, regardless of the form that is used. The date and time must be kept for each set of measurements. Other information that should be recorded is presented in this chapter. The information recommended for collection includes both design and construction of data and operational data.

DESIGN AND CONSTRUCTION RECORDS

The following outlines are data to be included in the construction specifications or to be defined by the hydrogeologist during construction (see Figures 10-1 and 10-2):

- Well diameter
- Proposed total depth
- Position of the screens with respect to a fixed reference point (e.g., top of flange)

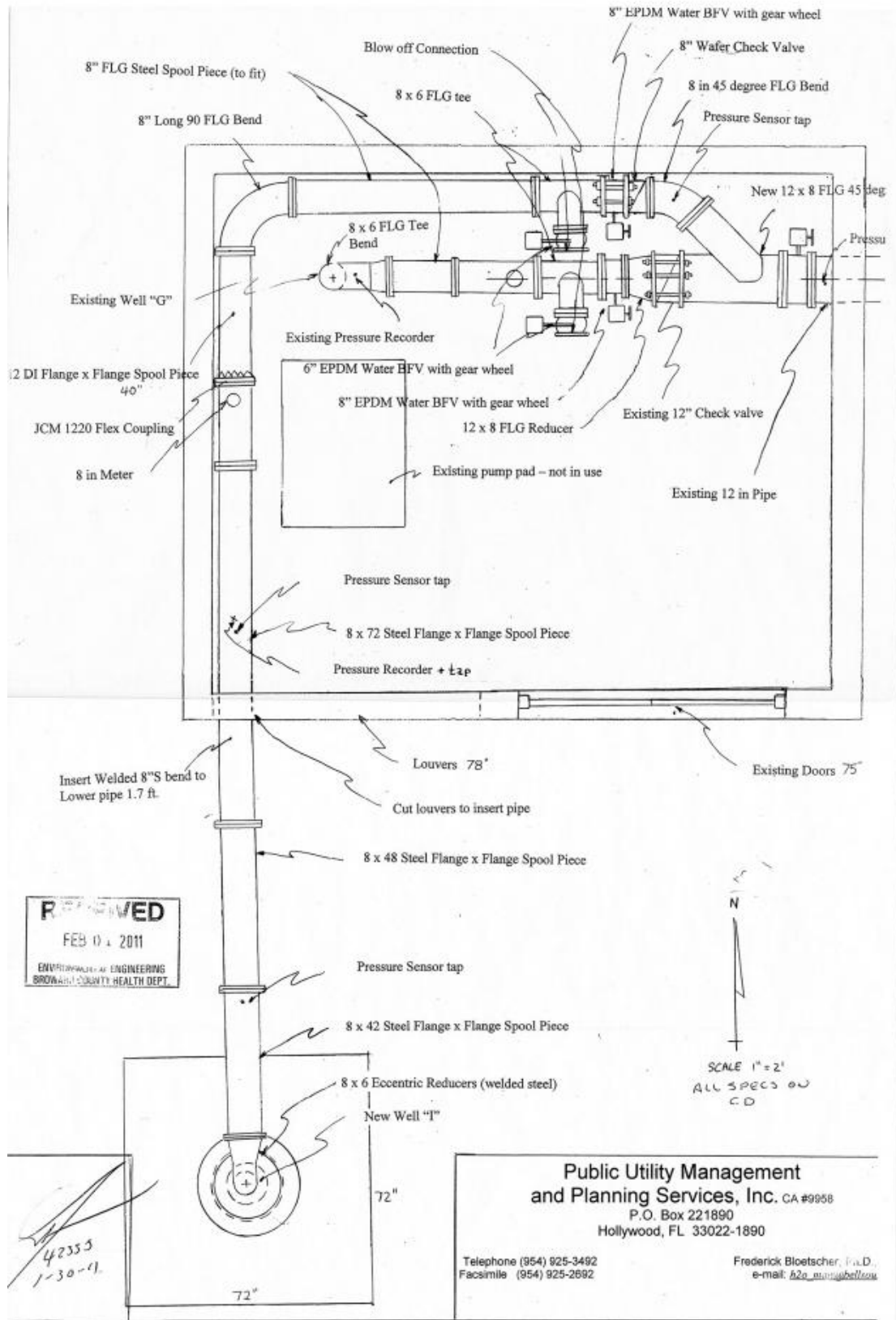

Figure 10-1 Well design



SOUTH FLORIDA WATER MANAGEMENT DISTRICT

January 15, 2010

PERMITTEE

CITY OF DANIA BEACH
100 W. DANIA BEACH BLVD.
DANIA BEACH, FL 33004

CONTRACTOR

ROYALL, JESSE L. JR.
5620 LEE STREET
LEHIGH ACRES, FL 33971
LICENSE NO:11316

WATER WELL CONSTRUCTION PERMIT #SF011110A
EXPIRATION DATE: July 15, 2010

PROJECT: DANIA BEACH PWS WELL G REPLACEMENT
TYPE OF USE: PUBLIC WATER SUPPLY
COUNTY: BROWARD SEC: 32 TWP: 50 RGE: 42

WELL CONSTRUCTION SPECIFICATIONS:	INNER	OUTER
CASING DIAMETER	20"	
CASING DEPTH:	60.00'	
SCREENED INTERVAL:		
OPEN HOLE INTERVAL	60' - 70'	
TOTAL DEPTH OF WELL:	70.00'	
GROUT REQUIREMENT		
Inner casing shall be grouted bottom to top.		

See additional conditions of permit on attached sheet.

We appreciate your assistance and cooperation in better managing the water resources of the District. If you have any questions on this matter, please call Ann-Marie Superchi at extension 6929.

Sincerely,

Ann Marie Superchi, Well Permitting
Water Use Division
South Florida Water Management District

Attachment: Additional Conditions of Permit

c: MR. DONALD CHARLETON

3301 Gun Club Road, West Palm Beach, Florida 33406 • (561) 686-8800 • FL WATS 1-800-432-2045
Mailing Address: P.O. Box 24680, West Palm Beach, FL 33416-4680 • www.sfwmd.gov

Source: City of Dania Beach, Fla.

Figure 10-2 Well drilling permit

- Portion of the open hole if constructed in rock
- Method of construction and materials to be used for the screen and casing
- Pump design (i.e., withdrawal capacity and head)

The following should be obtained after the drilling process is complete and the casing and well screens have been put in place (see Figure 10-3):

- Water-quality analyses
- Detailed individual well (geologic) logs
- Static (nonpumping) water levels in the aquifer
- Design pump discharge pressures
- Pumping water levels at design flow(s) to establish baseline conditions (original specific capacity)

When the production well has been constructed, “as-built” records of the well should be recorded. These records should include (see Figure 10-4)

- the method of construction used to drill the well
- the driller’s log of the materials encountered during drilling
- geophysical logs
- diameters (and materials of construction) of well casing and screens
- slot sizes of the screen
- the depths (settings) of the casing and screen
- surveyed location of completed well
- surveyed elevation of water level measurement point
- the total depth of the well

PUMP DATA

Pump data (see Figures 10-5 and 10-6) should include

- the type (and make, model number) of the pump installed
- the type and horsepower of the motor (driver)
- the pump setting (depth to the pump intake)
- the setting of the air line or other device for measuring the water level in the well
- notation for the point (and reference elevation) used for measurement of the water level
- all information provided by the pump and motor manufacturer, such as capacity and efficiency data to include the total dynamic head, diameter and number of bowls, pump speed (rpm), etc.

PERMIT MODIFICATION

FORM 0124
Rev. 11-90

City of DANIA BEACH 100W DANIA BEACH BLVD DANIA BEACH FL 33004
 Owner James Hall Address 11316 City 45' State FL Zip 33004
 Contractor's Signature _____ Completion Date 5/21/2010 Casing Depth 45' Total Depth 65' Well # 2 (REPLACEMENT)

SFWMD WATER USE PERMIT NO. SF 011106A

Grout Thickness & Depth	Casing & Screen Diameter & Depth	Depth (ft)		DRILL CUTTINGS LOG every 20 ft. Drill casing diameter. Give color, grain size, and type of material. Note cavities, depth to producing zones.
		From	To	
		0	20	BEAIND SANDS & ROCK
		20	30	LIGHT BROWN SAND & ROCK
		30	45	LIGHT BROWN MEDIUM SAND
		45	50	SAND & LIGHT GREY ROCK
		50	55	LIGHT BROWN SAND & LIME ROCK
		55	60	LIME ROCK & SANDS SOME CLAY
		60	65	HARD LIME ROCK & WHITE SAND
	12"	45'	45'	PLAIN 12" CASING FROM 45' AGL TO 45' BGL
24				CEMENTED 0-21' 20 STAKS
20	12"	45'	65'	JOHNSON SS SCREENED 20 STAK

Casing: Black Steel () Galv. () PVC () Fiberglass ()
 Screen: Type JOHNSON SS Slot size 20
 Screened from 45 (ft.) to 65 (ft.)
 Type of grout with % additives NIET CEMENT
 Water: Clear () Colored () Sulphur () Salty () Iron ()
 Conductivity _____ Chlorides _____ mg/l

TYPE OF WORK: Construct () Repair () Abandon ()
 WELL USE: Domestic Well () Public () Monitor () Test ()
 Irrigation () Fire Well () Other _____
 METHOD: Rotary with MUD () or Air () Cable Tool () Jet ()
 Casing Driven () Other _____
 STATIC WATER LEVEL 7.5 FL below top of casing
 PUMPING WATER LEVEL 35.8 FL after 4 Hrs. at 675 GPM
 PUMP SIZE 40 H.P. CAPACITY 1200 GPM (TEST PUMP)
 PUMP TYPE SUB INTAKE DEPTH 4-2
 From top of ground

LOCATION
 Located Near STIRLING RD
& SW 25 RD AVE, DANIA
 County BROWARD
 SE 92 S 50 E 47
 Section Township Range
26 2 52.67 80 10 16.71
 Latitude-Longitude

Cuttings sent to District? () Yes () No
 Note: PWS Wells attach a site map if well location is different from site location on permit application.

Source: City of Dania Beach, Fla.
 Figure 10-3 Well completion report

SOUTH FLORIDA WATER MANAGEMENT DISTRICT

TABLE A Description of Wells

Well Name or Number	G	H	I			
Map Designation	21916	21917	tbd			
Existing or Proposed	Existing+	Existing+	Existing+			
Date of Proposed Construction						
Date Installed if Existing	1976	1976	2010/2011			
Diameter (in)	18/12	18/12	20/12			
Total Depth (ft)	65	69	61			
Cased Depth (ft)	62	68	41			
Screened Interval (ft)	open hole	open hole	41-61			
Pumped or Flowing	P	P	P			
Pump Type (see Instructions)	Turbine	Turbine	turbine			
Pump Intake Depth (ft bls)	-25	-25	-30			
Pump or Flow Capacity (GPM)	1400	0	800			
Working Valve if Artesian (yes, no or not applicable)	y	y	y			
Status (see Instructions)	primary	monitoring	primary			
Purpose (see Instructions)	public water supply	monitoring	public water supply			
Elevation of the Wellhead (ft NGVD - see Instructions)	10.66	10.6	11.02			
Water Use Accounting Method (see Instructions)	metered flow	n/a	metered flow			
Date Last Calibrated (ATTACH calibration report)						
Planar Coordinates (if known - see instructions)	928110 E 624355 N	928112 E 624052 N	928110 E 624355 N			
Section / Township / Range						

Form 0645-G60 (08/03)

Source: City of Dania Beach, Fla.

Figure 10-4 Well summary information



Well G Future

Hydraulic Datasheet

Customer	:	Pump / Stages	: 14ENL / 2
Customer reference	:	Based on curve no.	: EC-2336
Item number	: dania well g future	Vendor reference	: 9999-W0000
Service	:	Date	: August 16, 2007
Operating Conditions		Materials / Specification	
Capacity	: 1250.0 USgpm	Material column code	: B30
Water Capacity (CQ=1.00)	: -	Pump specification	:
Normal capacity	: -	Other Requirements	
Total Developed Head	: 124.00 ft	Hydraulic selection : No specification	
Water head (CH=1.00)	: -	Construction : No specification	
NPSH available (NPSHa)	: Ample	Test tolerance : API-610 7th Edition	
NPSHa less NPSH margin	: -	Driver Sizing : Max Power(MCSF to EOC)with SF	
Maximum suction pressure	: 0.0 psig		
Liquid			
Liquid type	: Other		
Liquid description	:		
Temperature	: 60 °F		
Specific gravity / Viscosity	: 1.000 / 1.0 cSt		
Performance			
Hydraulic power	: 40.0 hp	Impeller diameter	
Pump speed	: 1775 rpm	Rated	: 9.87 in
Efficiency (CE=1.00)	: 63.4 %	Maximum	: 11.12 in
NPSH required (NPSHr)	: 12.9 ft	Minimum	: 9.25 in
Rated power	: 63.2 hp	Suction specific speed	: 11570 US units
Maximum power	: 75.9 hp	Minimum continuous flow	: 831.4 USgpm
Driver power	: 75.0 hp / 55.9 kW	Maximum head @ rated dia	: 173.4 ft
Casing working pressure (based on shut off @ cut dia)	: 75.1 psig	Flow at BEP	: 2223.3 USgpm
Maximum allowable	: 75.1 psig	Flow as % of BEP	: 56.2 %
Bowl & column hydrotest	: 93.8 psig	Efficiency at normal flow	: -
Minimum submergence	: 28.00 in	Impeller dia ratio (rated/max)	: 88.8 %
Pump thrust at rated flow	: 2030.5 lbf	Head rise to shut off	: 35.7 %
		Total head ratio (rated/max)	: 69.7 %

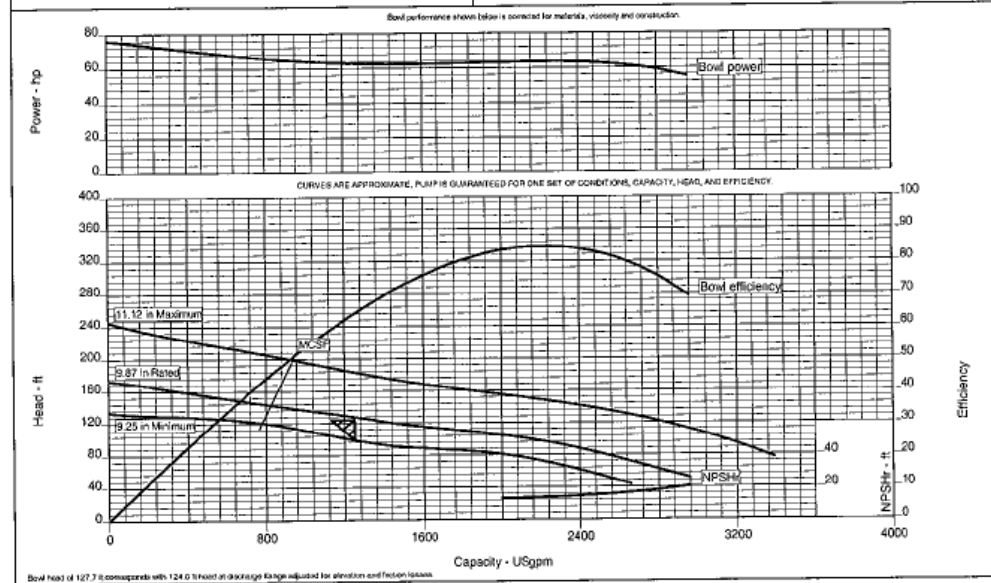

Source: City of Dania Beach, Fla.

Figure 10-5 Pump data, hydraulic data sheet

PUMP DATA SHEET Turbine 60 Hz

Company: _____ Customer: _____
 Name: _____
 Date: 06/09/10 Order No: _____



Pump:

Size: 8FDLO (2 stages)
 Type: Lineshaft
 Synch speed: 3600 rpm
 Curve: E6208FGPC0
 Specific Speeds: Ns: 3750

Pump Notes for Standard Sizes:
 Suction Size-6" Discharge Sizes-5",6". Curves are certified for water at 60°F only. Consult factory for performance with any other fluid.

Vertical Turbine: Bowl size: 7.5 in
 Max lateral: 0.56 in
 Thrust K factor: 9.9 lb/ft

Search Criteria:

Flow: 719 US gpm Head: 150 ft

Fluid:

Water
 Density: 62.25 lb/ft³
 Viscosity: 1.105 cP
 NPSHa: — ft
 Temperature: 60 °F
 Vapor pressure: 0.2563 psi a
 Atm pressure: 14.7 psi a

Motor:

Standard: NEMA Size: 40 hp
 Speed: 3600

Sizing criteria: Max Power on Design Curve

Pump Limits for Standard Construction:

Temperature: 120 °F Pressure: 400 psi g
 Sphere size: 0.5 in

— Data Point —
 Flow: 719 US gpm
 Head: 150 ft
 Eff: 81.3%
 Power: 33.5 hp
 NPSHr: 25.7 ft

— Design Curve —
 Shutoff Head: 234 ft
 Shutoff dP: 101 psi
 Min Flow: — US gpm
 BEP: 81.4% eff
 @ 724 US gpm
 NOL Pwr: 33.6 hp
 @ 676 US gpm

— Max Curve —
 Max Pwr: 34.5 hp
 @ 681 US gpm

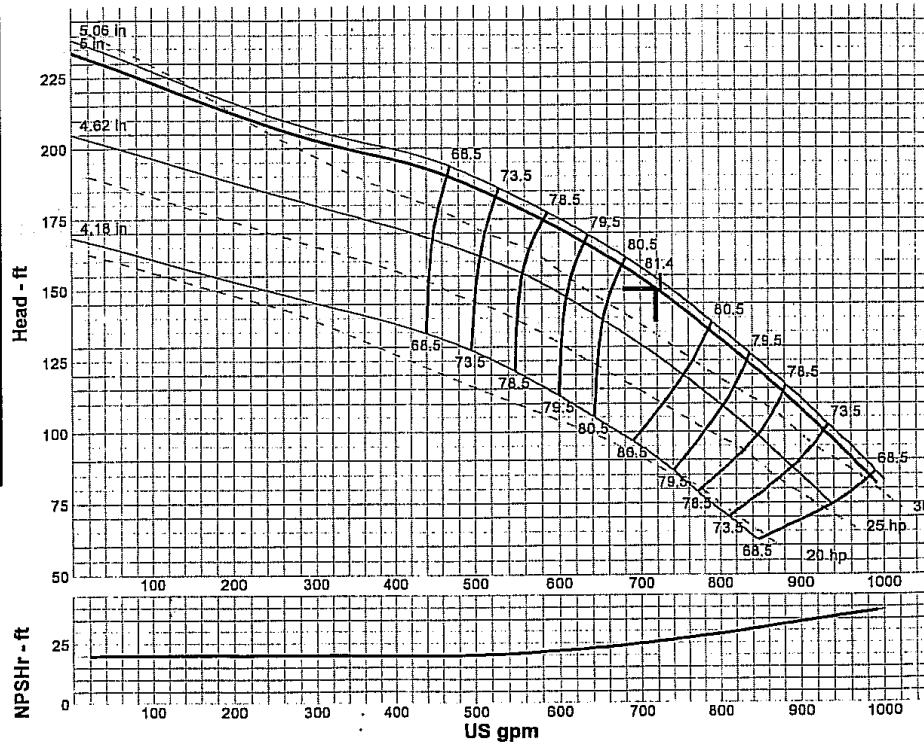

Performance Evaluation:

Flow US gpm	Speed rpm	Head ft	Efficiency %	Power hp	NPSHr ft
863	3450	117	78.8	32.4	31.9
719	3450	150	81.3	33.5	25.7
575	3450	176	77.9	32.7	21.4
431	3450	193	64.7	32.2	20
288	3450	204	48.1	30.6	20.2

Turbine V9

Selected from catalog: Goulds Lineshaft 60HZ Vers: 3.31

Source: City of Dania Beach, Fla.

Figure 10-6 Pump data, turbine 60 Hz

WELL ACCEPTANCE AND PUMPING TEST

A newly constructed well with a new pump should be evaluated as a unit to establish a standard to measure the performance in the future. Data should be collected to determine well losses that relate to well design and construction. Comparative data pertaining to the physical condition of the pump unit should also be collected. Proper study and comparison of such data enable the operator (or consultant) to anticipate maintenance and repair needs. Of course, after any repair or maintenance work, similar tests should be rerun. This data should include the following:

- Water level measurements made before, during, and after the (drawdown) pumping test
- A record of the pumping rate
- Hydrographs generated during the test
- Any raw data collected (manual or computer generated)
- A copy of the hydrogeologist's report on the procedures and test results

MONTHLY PUMPAGE

The total pumpage for each well should be recorded monthly (see Figure 10-7) and graphed to illustrate the seasonal and yearly production rates. This data can be used for future projection of water withdrawal rate and to monitor the actual volume of water produced from each well to predict periods between maintenance. This data can usually be recorded from a totalizer on flowmeters installed in the discharge piping for each well. Treatment should also be noted (see Figure 10-8).

SOUTH FLORIDA WATER MANAGEMENT DISTRICT						
Water Use Limiting Condition Compliance Report						
Quarterly Report of Withdrawals From Wells and Surface Water Pumps						
This Report must be completed and submitted to the District at the address shown as required by your Permit						
Permit Number	06-00187-W					
Project Name	CITY OF DANIA BEACH					
Issued to	City of Dania Beach					
Address	1201 Stirling Road					
City, State, Zip	Dania Beach FL 33004					
Phone / Fax No	954-924-3740 / 954-923-1109					
E-mail	doriando@ci.dania-beach.fl.us					
Return To:	South Florida Water Management District Attn: Water Use Regulation Division (4320) PO Box 24680 West Palm Beach, FL - 33416 - 4680					
Water Withdrawals, Million Gallons						
Requirement Name	District Identification Number	Month: Jan Year: 2012	Month: Feb Year: 2012	Month: Mar Year: 2012	Accounting Method	Date Last Calibrated
Well G Monthly pumpage	21917	3,875,000			Flow meter	8/9/2010
Monthly purchased from Broward Co.	06-00187-W	57,693,000			Flow meter	8/9/2010
Monthly withdrawal for WELL I	280022	10,704,000			Flow meter	6/6/2011
Name of Person Completing Form	Signature: <u>D. CHERIAN</u> <i>D. Cherian</i>					Date: <u>2/6/2011</u>
Form 0188-QMCH (08/03)						Printed: 09/28/2011
Page 3 of 4						

Source: City of Dania Beach, Fla.

Figure 10-7 Monthly pumping report

MONTHLY OPERATION REPORT FOR PWSs TREATING RAW GROUND WATER OR PURCHASED FINISHED WATER

PWS Identification Number: 4060253 Plant Name: Same

III. Daily Data for the Month/Year of:

Means of Achieving Four-Log Virus Inactivation/Removal: * Free Chlorine Chlorine Dioxide Ozone Combined Chlorine (Chloramines)
 Ultraviolet Radiation Other (Describe): "Conventional Filtration(2-log Virus Removal)"
 Type of Disinfectant Residual Maintained in Distribution System: Free Chlorine Combined Chlorine (Chloramines) Chlorine Dioxide

Day of the Month	Days Plant Staffed or Visited by Operator (Place "X")	Hours in Plant Operation	Net Quantity of Finished Water Produced, gal	CT Calculations, or UV Dose, to Demonstrate Four-Log Virus Inactivation, if Applicable*					Lowest Residual Disinfectant Concentration at Remote Point in Distribution System, mg/L	Emergency or Abnormal Operating Conditions; Repair or Maintenance Work that Involves Taking Water System Components Out of Operation		
				Peak Flow Rate, gpd	Lowest Residual Disinfectant Concentration (C) Before or at First Customer During Peak Flow, mg/L	Disinfectant Contact Time (T) at C Measurement Point During Peak Flow, minutes	Lowest CT Provided Before or During Customer Peak Flow, mg-min/L	Temp. of Water, °C			pH of Water, if Applicable	Minimum CT Required, mg-min/L
1	X	24	2,061,000	1,872,000	4.00	88.90	355.40	26.00	9.40	214.00	3.40	
2	X	24	1,910,000	1,872,000	3.80	88.90	337.60	26.00	9.40	214.00	3.70	
3	X	24	1,940,000	2,160,000	3.90	77.00	300.30	26.00	9.30	214.00	3.60	
4	X	24	1,801,000	2,160,000	3.90	77.00	300.30	25.00	9.30	214.00		
5	X	24	1,896,000	2,160,000	3.60	77.00	277.20	26.00	9.40	214.00		
6	X	24	1,861,000	2,448,000	2.80	67.90	190.20	25.00	9.10	214.00	3.90	
7	X	24	2,062,000	2,448,000	0.20	67.90	13.60	26.00	9.20	28.60	0.30	Began Annual Flushing-Switch to Free Cl.2
8	X	24	2,293,000	2,160,000	0.10	77.00	7.70	25.00	8.30	28.60	0.40	
9	X	24	1,924,000	2,160,000	1.1	77.00	85.00	25.00	7.30	28.60	0.12	
10	X	24	2,012,000	2,160,000	1.20	77.00	92.40	26.00	7.20	28.60	0.50	
11	X	24	2,041,000	2,160,000	1.20	77.00	92.40	26.00	7.20	28.60		
12	X	24	2,115,000	2,160,000	1.00	77.00	77.00	26.00	7.00	28.60		
13	X	24	1,984,000	2,160,000	1.00	77.00	77.00	25.00	7.10	28.60	6.00	
14	X	24	2,119,000	2,160,000	1.40	77.00	107.80	25.00	7.40	28.60	0.60	
15	X	24	2,367,000	1,872,000	1.60	88.90	142.20	25.00	7.00	28.60	0.80	
16	X	24	2,195,000	2,160,000	1.80	77.00	138.60	25.00	6.90	28.60	0.60	
17	X	24	2,178,000	2,160,000	1.90	77.00	146.30	26.00	6.90	28.60	0.90	
18	X	24	2,099,000	2,160,000	2.00	77.00	154.00	26.00	6.90	28.60		
19	X	24	2,044,000	2,448,000	1.40	67.90	95.10	26.00	6.90	28.60		
20	X	24	2,135,000	2,448,000	1.80	67.90	122.30	25.00	6.90	28.60	1.00	
21	X	24	2,402,000	2,160,000	1.80	77.00	138.60	26.00	6.80	28.60	1.50	
22	X	24	2,396,000	2,160,000	1.90	77.00	146.30	25.00	6.70	28.60	1.50	
23	X	24	2,041,000	2,160,000	1.80	77.00	138.60	26.00	6.90	28.60	0.50	
24	X	24	2,122,000	2,160,000	1.40	77.00	107.80	25.00	6.80	28.60	1.60	
25	X	24	1,998,000	2,160,000	1.40	77.00	107.80	25.00	6.70	28.60		
26	X	24	2,003,000	1,872,000	1.40	88.90	124.40	25.00	6.60	28.60		
27	X	24	2,248,000	2,160,000	1.80	77.00	138.60	25.00	6.70	28.60	1.50	
28	X	24	2,106,000	2,160,000	1.40	77.00	107.80	26.00	6.90	28.60	1.00	
29	X	24	2,375,000	1,872,000	1.00	88.90	88.90	26.00	7.10	28.60	0.80	
30	X	24	2,126,000	2,160,000	0.90	77.00	69.30	26.00	7.20	28.60	0.40	
31	X	24	2,232,000	2,160,000	0.90	77.00	69.30	25.00	7.10	0.00	0.40	
Total			65,086,000									
Average			2,099,548									
Maximum			2,402,000									

* Refer to the instructions for this report to determine which plants must provide this information.

Source: City of Dania Beach, Fla.

Figure 10-8 Monthly operations report

WATER LEVELS

Records of water levels in the well during periods of nonuse (static) and during pumping should be recorded along with associated flows. This allows for the calculation of the well's specific capacity (i.e., gpm/ft of drawdown that can be used to monitor well performance). The static levels can identify changes in the amount of water that may be available in the aquifer with time. The levels also provide a baseline for determining the amount of drawdown. Measurements of water level in observation and monitoring wells can also be used to evaluate static water levels in the aquifer at any given point. Monitoring pumping levels for any given well will illustrate the seasonal variations of pumping rates, river stage, water temperatures (well water and river), and drawdown with time. Trends in the pumping level with time can reflect losses in efficiency in the well over time.

WATER TEMPERATURE

The groundwater temperature should be recorded and plotted to obtain base data for determining future expectations of groundwater temperature. As the temperature of the groundwater varies, the capacity of the well fluctuates due to the viscosity of the water. Viscosity offers resistance to flow and is expressed as a coefficient of dynamic viscosity, or the force required to move a unit area a unit distance. In areas where recharge to the aquifer may come from infiltration of surface water, the temperature of the adjacent surface water body should also be recorded. The temperature records are used to evaluate infiltration and recharge, and where groundwater is under the influence of surface water.

SPECIFIC CAPACITY

The apparent specific capacity or ratio of the yield of each well to its drawdown, expressed in gallons per minute per foot of drawdown (gpm/ft), is used to plot the operational trend of each well. The apparent specific capacity for a well is determined by dividing the pumping rate (gpm) by the observed drawdown (ft) in the well measured at any specific time. Specific capacity depends not only on the transmissivity of the aquifer but also on well construction factors, such as screen type, well diameter, degree of aquifer penetration, and degree of well development. In general, when a well is new or new screens have been installed, the specific capacity is expected to fluctuate with pumping rate, river stage, temperature, aquifer water levels, and degree of screen efficiency.

DIFFERENTIAL

The differential between the pumping water level inside the well and the water level in the aquifer outside the well can be measured in any nearby monitoring or observation well. This value can identify changes in drawdown that relate to well production and efficiency or regional water level changes. The differences in water levels should be measured from surveyed elevations and plotted with time. The differentials are impacted by aquifer plugging from particle movement or biological factors and subsidence. When a well is new or has recently been redeveloped, the measured differential should be relatively small as the well screen and surrounding gravel-pack filter should be relatively unclogged. As the formation and well screen become plugged over time, this will increase the head losses in and around the well screen, measured by an increased differential in water levels. This change can also signal when well screen and formations are becoming plugged over time.

WELL MAINTENANCE

Well maintenance activities should also be recorded. These records should include

- the dates that maintenance was performed
- results of pre- and post-maintenance pumping tests
- methods (and materials) used in the maintenance procedures
- other factors such as the coloration of the pumped water, amounts of sand removed, odors, water quality analyses

This data, along with specific capacity, can be used to formulate a preventive rehabilitation/redevelopment plan to make sure facilities are operating under optimal conditions (see chapter 7), identify possible causes of well decline, and plan for annual budgets for well field management.

WELL ABANDONMENT

Records of any wells that are abandoned should also be maintained. These data should include

- survey coordinates of the well
- identification of markers or other indications of abandoned well location
- the date the well was taken out of service
- the date the well was properly abandoned
- a description of the methods and materials used to abandon the well
- reasons why the well was taken out of service
- historic performance records of the abandoned well

RECORDS FILING AND MAINTENANCE

If original records have been lost or not kept at all, manufacturers and well drillers, who maintain itemized records including details for original pumps sold and installed, can be contacted. These records should be collected and filed, or incorporated into a permanent file system. Copies of those records give indications of the original pumping levels and head conditions. They may also indicate general area changes in water levels. Actual drilling logs may be replaced by running gamma-ray logs in both new and old wells and then compared to correlate formation compositions. Changes in water quality may be documented in state health agency files and be relevant to well maintenance. "Retroactive" historic data of local aquifer conditions may also be available through records maintained by regulatory agencies.

Groundwater Recharge and Storage Programs

Recent investigations have studied the feasibility of using groundwater to protect water resources, recharge well fields, store water, and create indirect potable water systems. These techniques involve injecting treated or treatable water beneath the surface, rather than discharging it. Aquifer storage and recovery (ASR) uses an aquifer formation as an underground storage tank that can be withdrawn during high-demand periods or droughts. With aquifer reclamation, large quantities of high-quality water are injected into a contaminated aquifer. The most promising application of this technology is injection of fresh water into aquifer zones in coastal areas with highly transmissive formations contaminated with saltwater. Artificial aquifer creation and artificial recharge is similar to aquifer storage, recovery, and reclamation. Treatable water is injected into an aquifer zone devoid of water, or one with lower quality water that is displaced. Another option is highly treated wastewater that may be used for indirect potable reuse (Muniz et al. 2006).

This chapter provides an overview of these groundwater recharge techniques. First, federal regulations that govern groundwater recharge and storage are introduced. An outline of the typical technologies is presented. Case studies illustrate how water suppliers have applied the techniques. Further information can be gathered from a number of sources including publications by AWWA (see Bloetscher et al. 2005). It should be noted that these sites are primarily in Florida (54 sites), California, and New Jersey. There are two test sites in Canada. Most Colorado sites have been abandoned, and Oregon's sites are mostly in the test mode. As a result, the examples included may reflect the technologies used for the longer-term projects that are primarily in Florida and California.

UNDERGROUND PROTECTION CRITERIA AND STANDARDS

In the United States, federal regulations, such as 40 CFR 144 and 146, give standards for underground injection projects. The rules were established under the authority of the Safe Drinking Water Act approved in 1974 and amended in 1986 and 1996. The regulations include an extensive set of definitions concerning injection wells. Many states have their own regulations that provide additional requirements to the federal rules (Muniz et al. 2006).

Class I injection wells are used by generators of hazardous waste, or owners and operators of hazardous waste management facilities. Hazardous wastes are injected beneath the surface but above the lower-most formation used for drinking water and more than ¼ mi from an existing well used for drinking water. Industrial and municipal wastewater disposal wells that inject wastewater effluent are also included. The state of Florida uses Class I injection wells almost exclusively for the disposal of treated wastewater that cannot be disposed of due to weather or lack of other disposal options (Bloetscher et al. 2005).

Class II wells inject fluids that are brought to the surface in oil and natural-gas production. These wells also enhance recovery of oil and natural gas and the storage of hydrocarbons at liquid temperature. Class III wells are used for mineral extraction. Class IV wells inject hazardous radioactive wastewater below the lower-most drinking water zone (see Bloetscher et al. 2005).

Class V wells are all wells that are not included in Class I, II, III, IV, or VI. Class V wells include

- air conditioning return wells
- cooling water disposal wells
- drainage wells
- dry wells for injection of wastes
- recharge wells for replenishing water
- saltwater intrusion barrier wells
- wells to inject water into freshwater aquifers, sand backfills, and other wells to inject a mixture of water and sand
- septic system wells

The regulations establish corrective actions for well failures and requirements for mechanical integrity tests to determine that there are no leaks in the casing, tubing, or packer. The regulations also establish that fluid does not enter an underground drinking water source through vertical channels adjacent to the well. The testing methods to achieve these results are included in the regulations (see Bloetscher et al. 2005).

Under subparts B, C, D, E, and F, the criteria and standards that apply to Class I, II, III, IV, and V wells are established. Each of these subparts establishes construction requirements; operating, monitoring, and reporting requirements; and information required in granting well permits. The information includes

- the proposed operation of the well (such as maximum daily rate of flow, volume of fluids to be injected, and the average injection pressure)
- the source of the water
- the analysis of the characteristics of the injected fluids
- the appropriate geological data
- the construction details of the well

Class VI are the newest injection wells. These wells are specifically designed to inject carbon dioxide (CO₂) for long term storage, also known as *geologic sequestration of CO₂*. There are no current operational wells, however as many as 10 test wells are expected by 2016 (USEPA 2013).

Applicants for a well permit must provide a performance bond or other guarantee that the applicant will close, plug, and abandon the well according to federal regulations (see Bloetscher et al. 2005).

AQUIFER STORAGE AND RECOVERY

ASR is used in potable and nonpotable water systems (Muniz et al. 2003). ASR technology can increase the efficiency of water system operations. During wet or low-demand portions of the year, unused water treatment plant capacity can be used to treat water that is injected into an aquifer. The injected, treated fresh water displaces the native water in the aquifer. Because of the density difference between the treated freshwater and saline water, a “bubble” of fresh water will form when injected into brackish water sources (Bloetscher et al. 2005). While a large mixing area will occur, adequate fresh injected water will keep the bubble available for potable water supply augmentation for some period of time (Muniz et al. 2006).

When the full treatment plant capacity is required, injection is discontinued. If demand increases beyond plant capacity, fresh water is recovered from the aquifer, disinfected, and blended with treated water. Excess water can be left in storage as an emergency supply. Figure 11-1 illustrates the process (Bloetscher et al. 2005).

Effective use of ASR technology can reduce water treatment facility expansions (Bloetscher 2001). Considerable expense can be saved by the more efficient overall operation of the treatment facility, especially membrane facilities designed to run 24 hr a day. System pressure will generally be sufficient for injection, and recovery costs are minimal, requiring only minor pumping costs and disinfection (Muniz et al. 2006).

Nonpotable ASR use has been proposed in some areas. These projects inject surface water, runoff, or water pumped from the surficial aquifer during wet periods. Water quality regulations limit nonpotable ASR uses at this time. Nonpotable water often has to be treated both before and after recovery, but where raw water is of sufficient quality to permit injection without treatment, the utility saves money at the time of injection (Bloetscher and Muniz 2010; Bloetscher 2001).

There are more than 200 sites nationwide that have either utilized or investigated the concept of ASR, with about 50 of them having installed capacity (Muniz et al. 2003). Parameters that are important in identifying this recovery percentage potential are (Bloetscher 2001)

- time (from the perspective of how long a period of time the water needs to be stored prior to recovery)
- water quality
- size of the transition zone
- hydraulic conductivity
- dispersion within the aquifer
- buoyancy forces created by the density differentials
- quantity of water injected
- porosity
- absorption and desorption

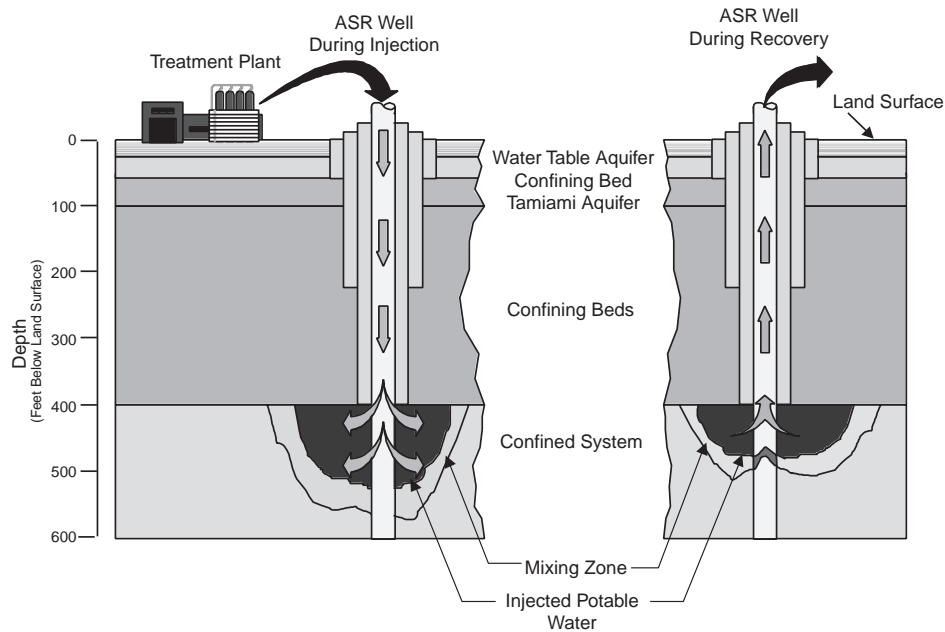

Figure 11-1 ASR conceptual diagram for brackish water aquifers

- change in the density of water that is stored or injected after the bubble has been formed

Issues that have not been clarified include (Bloetscher 2001)

- the definition of success
- long-term storage efficiency
- bubble dynamics

An issue that has occurred in some areas is the release of arsenic or other metals. This needs to be studied at all potential sites to ensure the geochemistry does not disrupt the success potential of any given site. Future ASR projects should focus on defining the long-term usefulness of ASR as a water management tool, answering these questions, and verifying the theoretical expectations of the current models, or providing data sufficient to modify same.

Collier County, Fla., is among those that have tested the concept by injecting potable water into the brackish Hawthorn aquifer zone and withdrawing water with up to 200 mg/L chlorides. Seven cycles have been completed as of 1998, indicating that the concept is viable. The retrieved water will only require disinfection before mixing with potable water and pumping into the distribution system (see Figure 11-2). The County continued to operate the well until 2010.

Peace River ASR Project

The Peace River Manasota Regional Water Supply Authority provides for the regional public water supply needs of Charlotte, DeSoto, Manatee, and Sarasota counties in southwest Florida. The Authority owns and operates a 12-mgd regional water supply and treatment facility on the Peace River. This facility serves users in Charlotte County, southern DeSoto County, and one municipality in Sarasota County. The Peace River Manasota Regional Water Supply Authority has successfully operated an ASR system for many years.

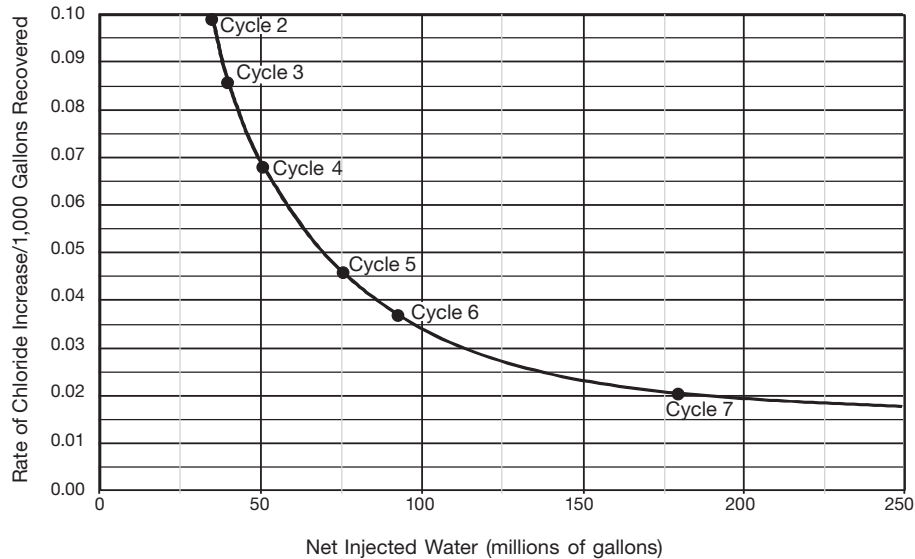

Source: Bloetscher 2011, et al. 2005

Figure 11-2 Collier County, Fla., ASR project graph showing recovery efficiency improvement for each succeeding cycle

The Peace River is the largest flowing surface water body in Florida: a 2,480-mi² watershed that measures approximately 105 mi from Charlotte Harbor. Near the intake structure of the Peace River Regional Water Supply Facility (PRRWSF), the river has an annual average flow of 970 mgd. Regulating requirements limit the amount of the river flow that can be diverted to 10 percent, theoretically providing 97 mgd for public water supply.

The Peace River flow is seasonal with wet seasons (typically summer months) and dry seasons (typically winter and spring months). As a result, the Authority's permit to withdraw from the Peace River prohibits any diversion from the river when the flow is less than 84 mgd. Using the Peace River as a supply source requires adequate water storage during high wet season flows.

Figure 11-3 is a schematic of the existing Peace River water supply and treatment system. Facilities consist of a diversion structure, an off-stream reservoir, a surface water treatment plant, an ASR system, and aboveground storage. The Peace River has no dams, so all seasonal storage must be provided by the off-stream reservoir and the ASR system.

Figure 11-4 is a cross-section of the ASR system. Two operational storage zones are used at the facility. The upper storage zone is identified as the Tampa Limestone, located between 400 ft and 500 ft below land surface. Only one well penetrates this zone due to its relatively low water-producing ability and the proximity of nearby domestic wells. The major ASR zone is the Suwannee Limestone, located between 600 ft and 900 ft belowground. The native water quality of this zone is nonpotable, having total dissolved solids (TDS) of approximately 800 mg/L. Eight ASR wells (with yields of approximately 1.0 mgd each) currently are completed and operating in the Suwannee Limestone. An additional ASR storage zone was tested in the Avon Park Limestone, a fractured limestone and dolomite formation beginning approximately 1,300 ft below land surface. The Avon Park Limestone is a high water-producing formation (well yields up to 3.0 mgd) with a TDS of approximately 2,000 mg/L.

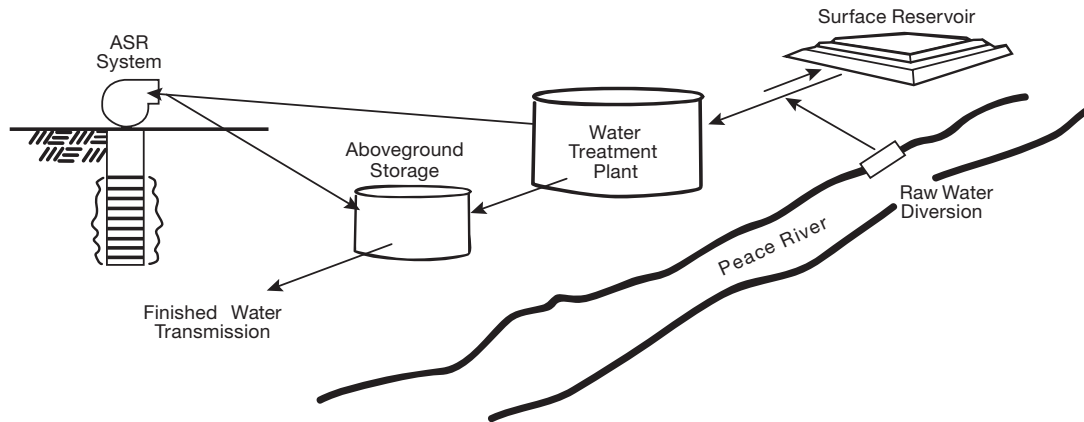

Figure 11-3 Schematic of Peace River ASR system

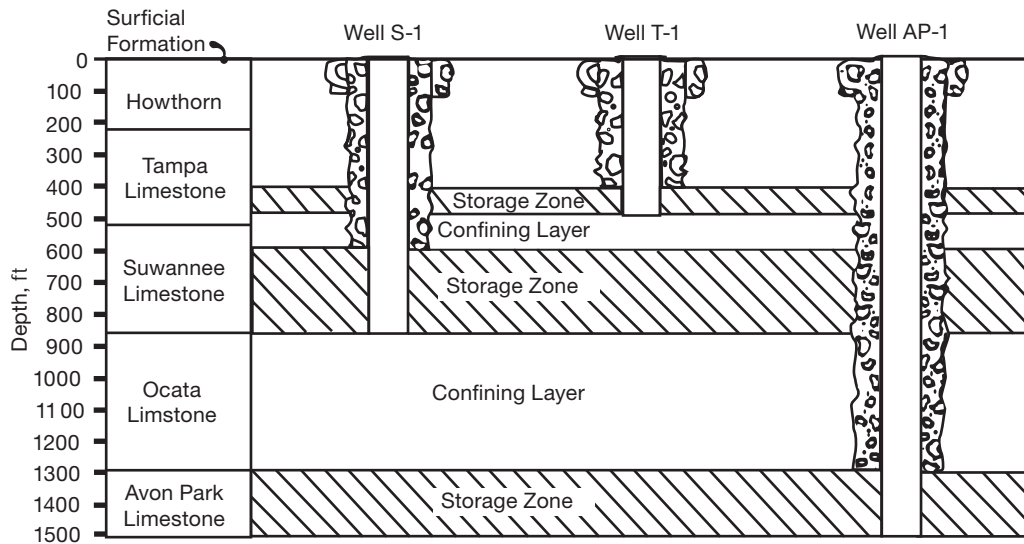

Figure 11-4 Cross section of the ASR system

The PRRWSF’s ASR wells are operated as needed to store treated drinking water when Peace River flow is available for withdrawal and system demand is less than the treatment capacity. The treated water is recovered from the ASR system when river flow is low and water demands are high. The operations staff monitors the ASR system for injected and recovered flow rates from the wells, cumulative volumes stored, the water quality of the injected water, and water quality of the recovered water. TDS is an overall indicator of potable water quality. Water produced by treating Peace River water is typically 300 mg/L.

Figure 11-5 shows the historical operation of the ASR wells at the facility. Storage cycles are shown as positive values on Figure 11-5 while recovery cycles are shown as negative values. Storage and recovery cycles alternate quite frequently, rather than as long wet season storage cycles followed by long dry season recovery cycles. This operational pattern is a result of characteristics of Peace River flow that result in high flow events of a short duration, combined with regulatory restrictions that prohibit diversions of more than 10 percent of the river flow on any day.

Figure 11-6 shows the cumulative volume in storage for the existing ASR system at the PRRWSF. The quantity of water in storage has increased over time; currently over 1.6 billion gallons of treated drinking water is stored among the nine ASR wells. Also apparent on Figure 11-6 are the time periods in which water was withdrawn to meet extended high demand periods. A pattern of building storage volume, even while water demands increase, is typical of many ASR systems. This buildup of storage volume in the early years of a water treatment plant expansion, when water demands are low, allows a delay before additional facility expansions are needed to meet increased demands.

Figure 11-7 shows the depletion of storage and the TDS of water produced from the ASR wells during one of the historical extended recovery periods, from late November 1991 to late February 1992. Approximately 268 million gallons of water were recovered from the ASR system during this three-month withdrawal period, and the TDS remained below the 500 mg/L TDS drinking water standard. Figure 11-8 shows the results of a more recent extended recovery period that occurred between January and May 1996. During this recovery period, a total of approximately 483 million gallons of water were recovered from the ASR system.

According to PRRWSF engineers, during this five-month extended recovery period, the TDS concentration of the recovered water appeared to have stabilized below approximately 500 mg/L, although data had some scatter. This stable water quality is a significant finding from the second extended recovery period. At some point, degeneration will occur when the transition zone is being pumped. Typically, TDS values increase throughout the recovery period until the targeted volume of water from the ASR well has been withdrawn.

The ASR system is designed to provide a six-month supply of water that meets drinking water quality standards. The six-month supply quantity was determined through an analysis of historical flow records of the Peace River. The longest historical period in which no diversion from the river was allowed was seven months during a very severe drought in 1985.

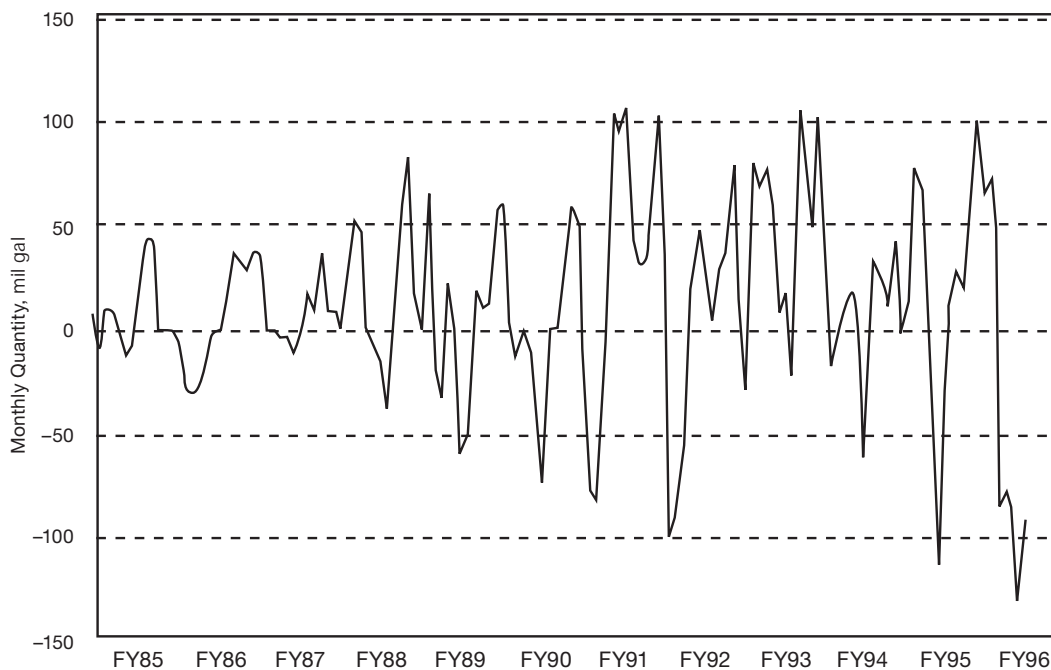

Figure 11-5 Historical operation of the ASR wells

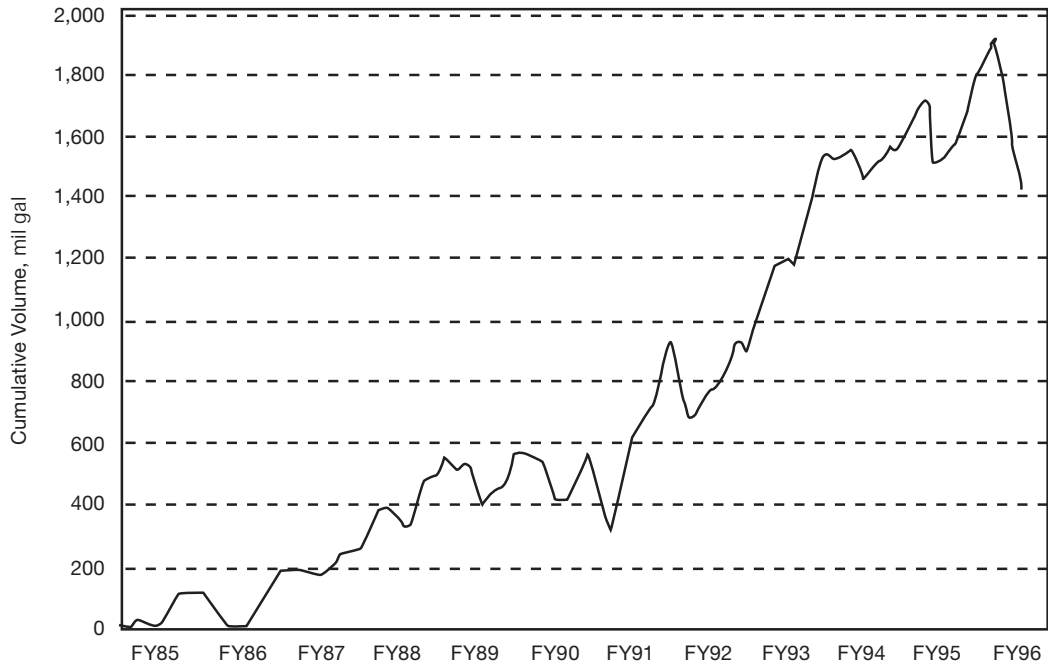

Figure 11-6 Cumulative volume in storage

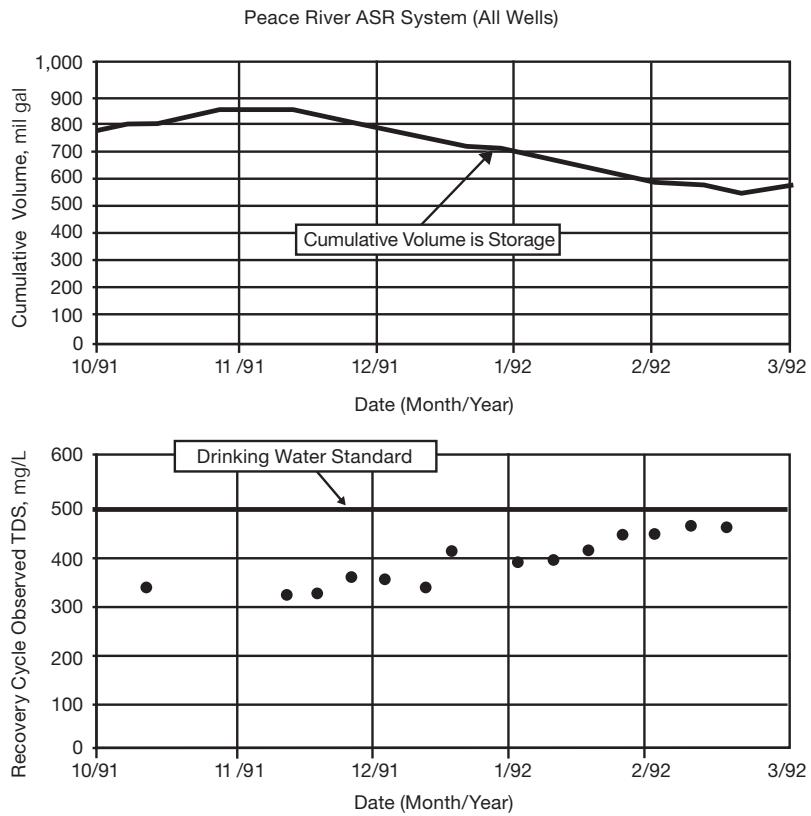

Figure 11-7 Depletion of storage and the TDS of water

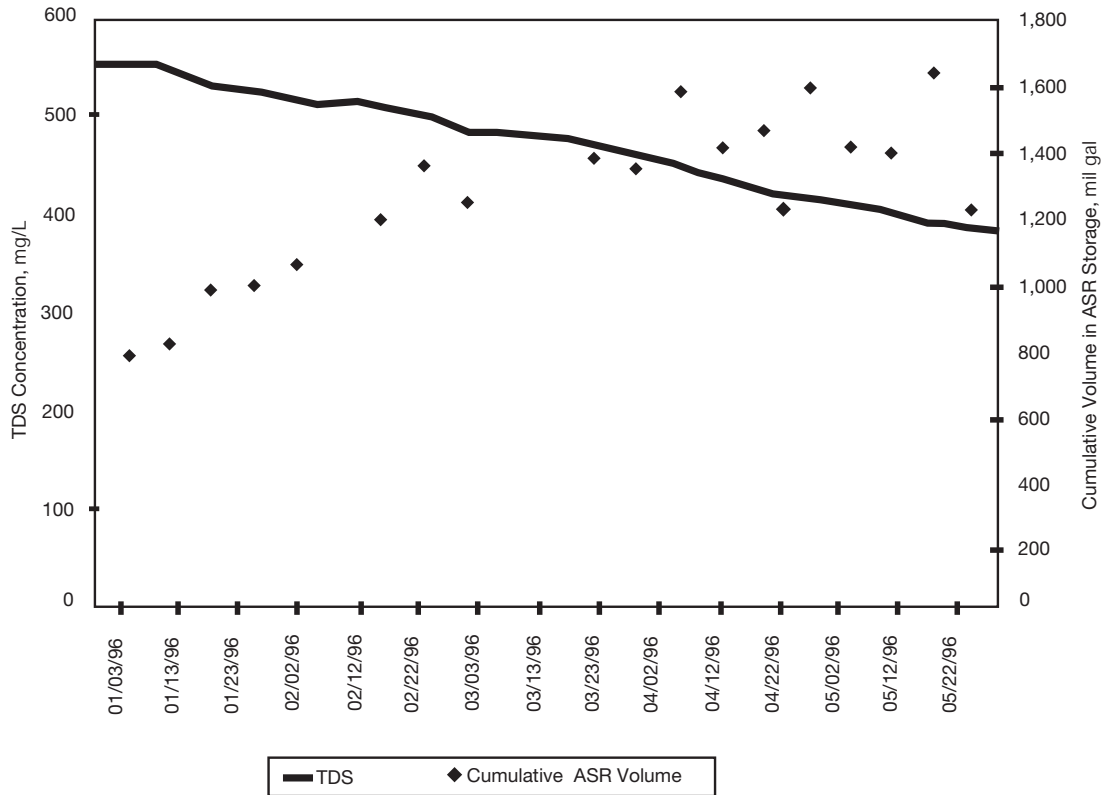

Figure 11-8 Results of a recent extended recovery period

Testing performed at the PRRWSF's ASR wells determined that each Suwannee Limestone well needs to have 350 million gallons of water stored to meet a six-month dry season. The Suwannee Limestone wells have a nominal capacity of 1.0 mgd. During a six-month recovery period, approximately 180 million gallons of water would be produced from each well. This means that approximately 50 percent of the water stored can be recovered at any one time to meet the available demands. Total recovery increases over time from 50 percent to nearly 100 percent of the water injected during successive storage and recovery cycles. PRRWSF continues to add more wells to increase future water supply availability.

AQUIFER RECLAMATION

Aquifer reclamation is a technique where large quantities of higher quality waters are injected into a contaminated aquifer. A key application is the injection of fresh water into aquifer zones contaminated by saltwater. The fresh water may stabilize the salinity front or force it to retreat. This technique can be widely applied in coastal areas where saltwater intrusion has occurred.

When the aquifer head is reduced by development or drainage, saltwater continues to move and contaminate the aquifer formation. Because this movement is slow, proper injection procedures can push the intruded saltwater (isochlor line) back toward the ocean by increasing the aquifer head. No drinking water well fields should be downgradient from the proposed injection area. Withdrawal downstream of the injection wells could frustrate efforts to increase aquifer head. The quality of the injected water could affect the aquifer, especially if the water is of lesser quality.

City of Hollywood Salinity Barrier Project

In 1994, the city of Hollywood, Fla., undertook a pilot program to inject effluent into the Biscayne Aquifer to retard saltwater migration. The city proposed injecting highly treated wastewater effluent into the production zone of the Biscayne Aquifer. The effluent would meet all the requirements for spray irrigation on publicly accessible lands. The injection would parallel the Atlantic Ocean in an area where saltwater intrusion has already contaminated the aquifer (Bloetscher et al. 2005).

The effluent would be injected into the lower-half production zone of the Biscayne Aquifer (see Figure 11-9). The buoyancy of the fresh water will cause it to rise slowly toward the surface (see Figure 11-10). Combined with the hydraulic gradient of the Biscayne Aquifer, the plume will move toward the ocean (see Figure 11-11).

While some mixing will occur, the effluent will displace the saltwater and push the isochlor line toward the ocean (see Figure 11-12). If the program is continuously operated with a series of wells, this movement should provide a permanent barrier to saltwater migration as the effluent water quality is better than the intruded saltwater, which should make the program feasible. Testing of the concept was completed using potable water, with a transition to raw water. However the ultimate goal of testing with reclaimed water was not pursued due to regulatory concerns about water quality of the injectate. The program's implementation would permit large amounts of effluent, most of which is discharged into the ocean (or potentially deep injection wells), to be injected along the coast as a salinity barrier (Bloetscher et al. 2005).

West Coast Basin Barrier Project

Due to its growth, Southern California has experienced an increasing shortage of dependable water supplies. Approximately two thirds of the region's water supplies are imported from Northern California, the Colorado River, and the eastern slopes of the Sierra Nevada Mountains. All three of these sources have become increasingly undependable. Owens Valley and Mono Basin supplies from the eastern slopes of the Sierra Nevada Mountains have been restricted by court decisions and agreements. This decreases the amount of water available to supply the West Coast Basin Barrier Project (WCBBP).

Decreasing dependable supplies of imported water, combined with the recent prolonged drought in Southern California have heightened public awareness of the need to conserve existing water supplies and develop new sources. This need is particularly acute within the Metropolitan Water District of Southern California (MWD) service area, consisting of 5,200 mi² and 17 million people. Population growth and economic development have stretched existing water supplies to the limit. One alternative source of water that is receiving increased attention is water reclamation. An annual average of approximately 360 mgd is currently disposed of by the Hyperion Wastewater Treatment Facility through an outfall pipe extending 5 mi into the Santa Monica Bay. Water reclamation uses proven technologies to treat domestic wastewater to a level acceptable and safe for many applications. Because much of this wastewater is currently discharged to the ocean, water reclamation provides an opportunity to conserve and reuse a scarce natural resource.

The Los Angeles County Flood Control District constructed the WCBBP in the 1950s and 1960s. Water imported by MWD was injected into the coastal reaches of local aquifers for mitigation of saltwater intrusion. The WCBBP consists of two sections of pressurized pipeline connecting about 150 injection wells. The injection wells are screened at selected depths ranging from 280 ft to 700 ft to allow water injection into three different aquifers. An average of approximately 20,000 acre-ft/yr of potable water has been injected by the WCBBP. However, more water is needed and the district is looking at using wastewater effluent to supplement the injection program.

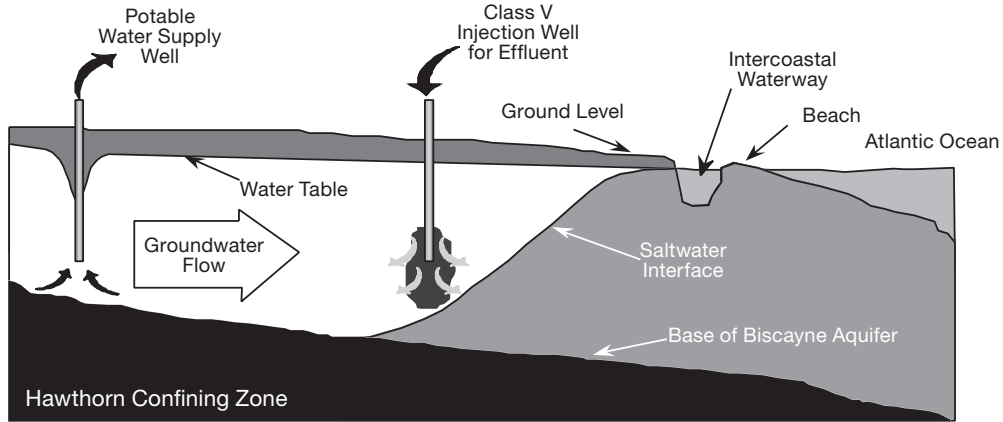

Source: Bloetscher et al. 2005

Figure 11-9 Biscayne Aquifer reclamation water movement after injection

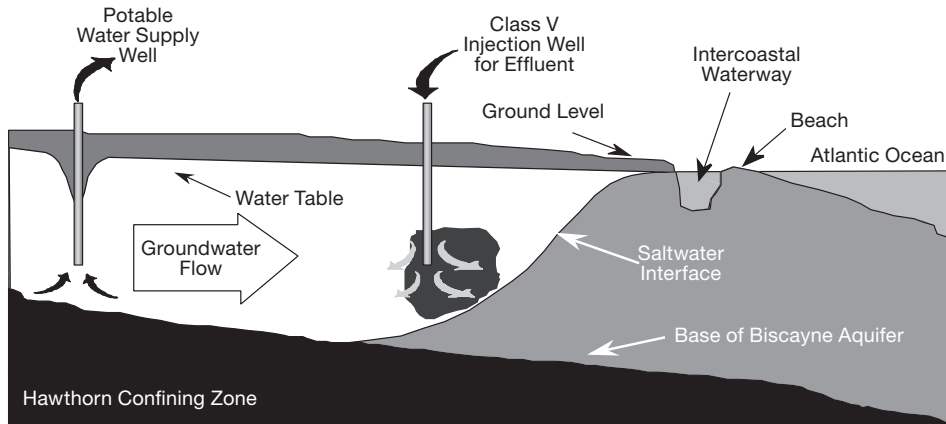

Source: Bloetscher et al. 2005

Figure 11-10 Biscayne Aquifer reclamation buoyancy movement after injection

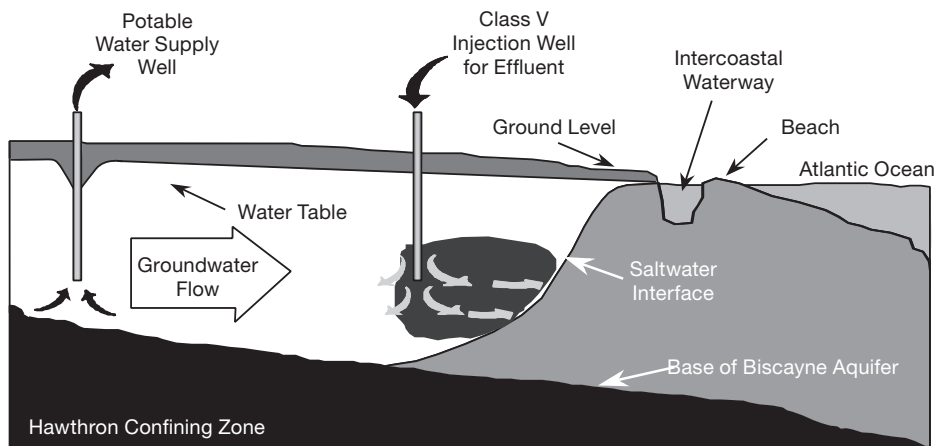

Figure 11-11 Biscayne Aquifer reclamation injection well location

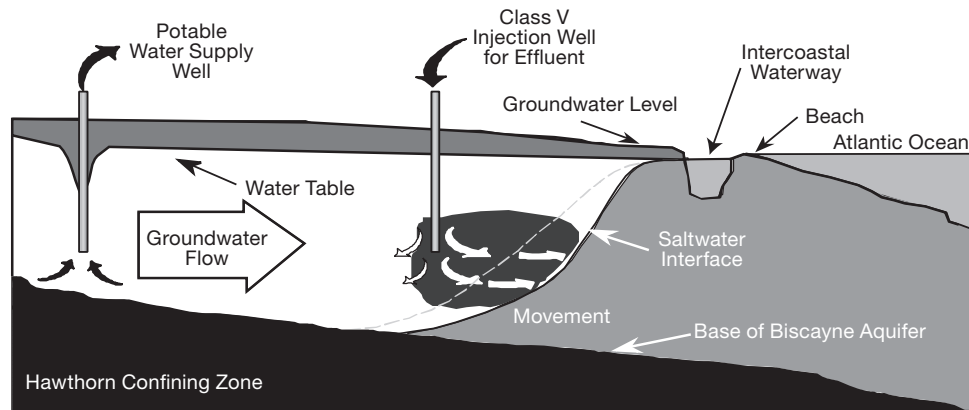

Figure 11-12 Biscayne Aquifer reclamation water movement after injection

In May 1990, West Coast Basin Barrier District proposed reclaiming 62.5 mgd (70,000 acre-ft/yr) of Hyperion's effluent at an advanced wastewater treatment facility located in El Segundo. This reclaimed water is now distributed for a wide variety of uses, including the WCBBP, to prevent seawater intrusion into local aquifers.

The major project elements of the WCBBP include

- Hyperion treatment facilities (430 mgd)
- Force main delivery pipeline
- West Basin Water Reclamation Plant (WBWRP)
- Barrier blend facility
- Reclaimed water distribution system
- West coast basin barrier project

Secondary effluent is pumped from the City of Los Angeles Hyperion Treatment Facilities to the WBWRP through a 60-in. diameter delivery pipeline. The WBWRP treats the secondary effluent to levels that meet the reclaimed water quality requirements of the different user groups. The reclaimed water is distributed to the individual users through an extensive distribution system. Before delivery to the WCBBP, the reclaimed water is blended with imported water at the barrier blend facility (see Figure 11-13).

The WBWRP will be located in El Segundo. The reclaimed water treatment process for the West Coast Barrier injection includes pre-decarbonation, lime and soda ash softening, pH adjustment, filtration, reverse osmosis (RO), post-decarbonation, and disinfection (see Figure 11-14). The reclaimed water treatment rate of about 5 mgd for Phase I, and the ultimate rate of about 20 mgd were selected as the basis for hydraulic sizing of the water reclamation plant (WRP).

A 30-in. pipeline delivers the reclaimed water from the reclamation plant to the barrier blend facility located on El Segundo Boulevard. The facility blends reclaimed water with the potable water.

Reclaimed water should be provided on a continuous basis for injection into the barrier in sufficient quantities to maintain injection barrier pressures. The quantities of imported water may vary seasonally depending on actual demands, availability of imported water, and pricing incentives provided by MWD. The program was reviewed and updated in 2008.

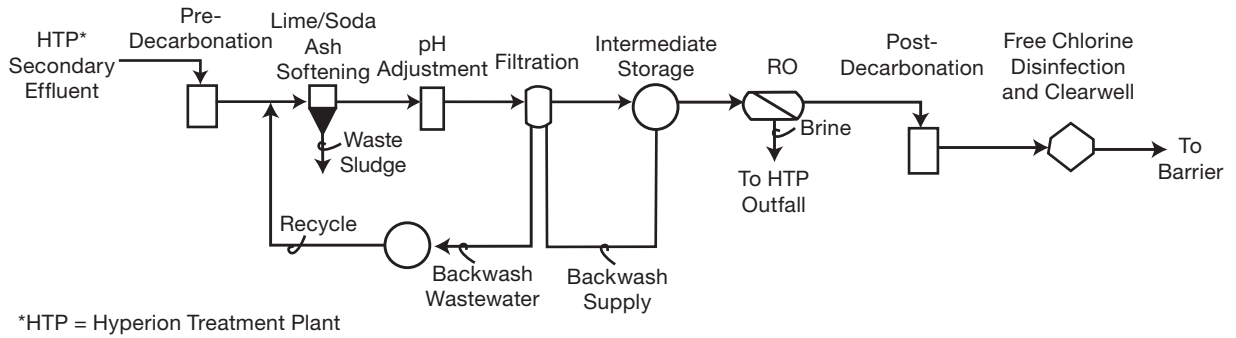

*HTP = Hyperion Treatment Plant

Figure 11-13 Schematic of treatment process

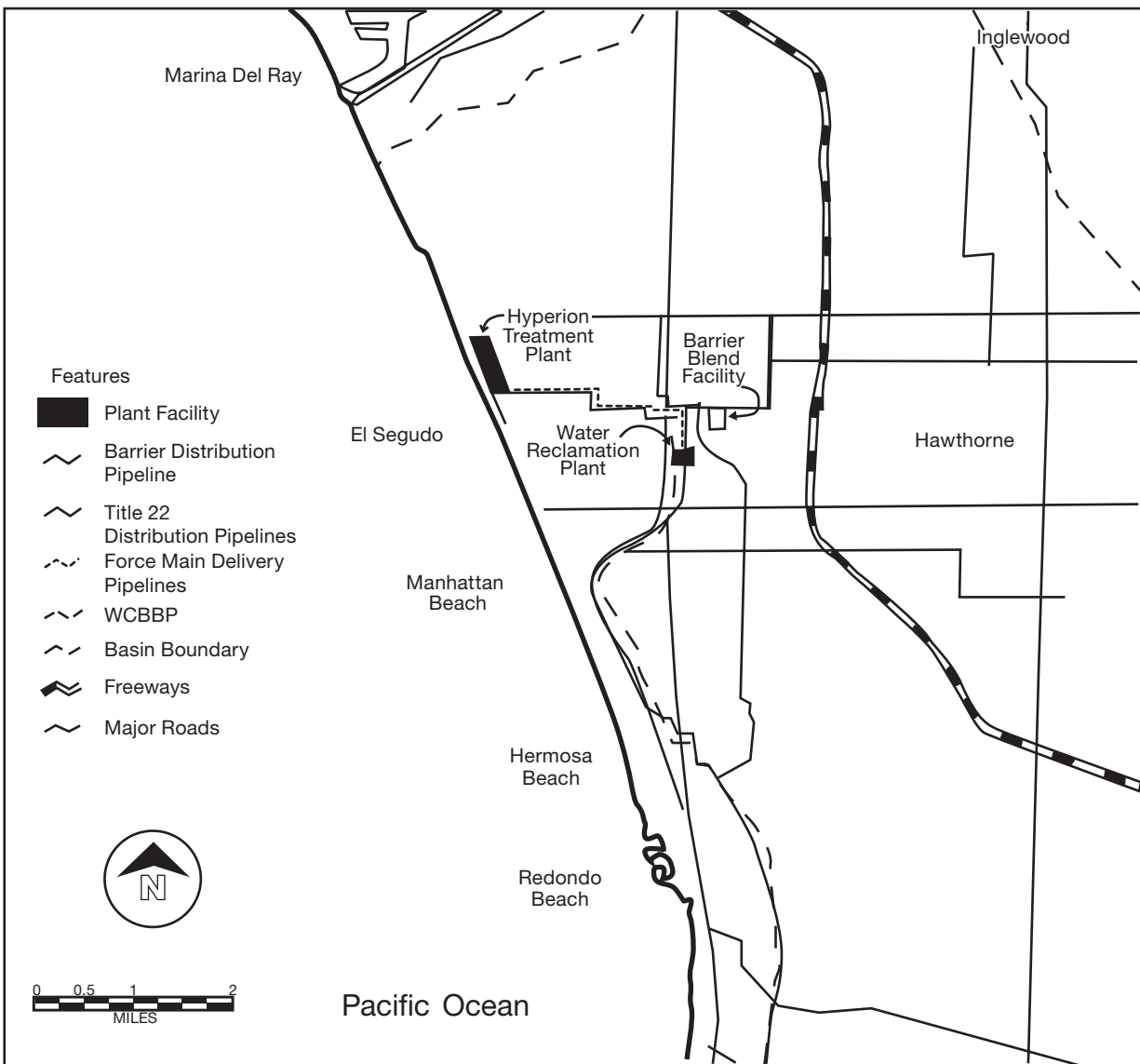

Figure 11-14 Location of the WRP

ARTIFICIAL AQUIFER CREATION AND RECHARGE

Artificial aquifers are created by injecting treatable water into an aquifer zone that is devoid of water. The injection can also displace lower quality water for retrieval down-gradient. Given the slow movement of water in aquifers, recharge may be able to supply small water quantities, or supplement existing water during times of aquifer stress. Where an aquifer has been depleted, the technique is viable.

Aquifer recharge, or artificial recharge, is similar. Water is injected at a point that allows the water to flow into a well field zone. The aquifer head is raised so that a driving head is created to push water (Figure 11-15). Although water can be produced from an aquifer in full turbulent flow, it cannot be recharged in turbulent flow conditions. Typically the recharge rate of a well is 20 percent to 50 percent of the flow or pumping rate.

In some instances, such as the Everglades Water Conservation Areas, the area is flooded to create an artificial aquifer head that increases percolation and aquifer storage. Downstream well fields can take advantage of the higher water levels, creating an increase in total water supplies (Figure 11-16).

Aquifer recharge systems may also be applied to brackish water supply zones that tend to degrade over time. High-quality water is injected beneath the withdrawal zone, as shown in Figure 11-17, so that the upcoming high-quality water is withdrawn, rather than saltwater. This use is important in reverse osmosis systems. As water quality degrades over time (higher TDS and chlorides), new membranes and more expensive pumps will likely be needed.

Targeted aquifer recharge is the most likely scenario here. The use of stormwater and reclaimed wastewater are possible examples. A limited number of people have looked at these options. The City of Hollywood Florida tested the salinity barrier concept in the 1990s, but regulatory hurdles prevented them going forward. Many utilities, including Miami-Dade County, Plantation, Pembroke Pines, Sunrise, and Davie, Fla., have begun testing aquifer recharge from an indirect potable reuse perspective. Much of the issue relies on ensuring public health is protected. As a result in some areas, RO is required to meet the injection standards. However, the cost may not be as significant as expected.

Pembroke Pines, Fla., Indirect Potable Reuse Project

Water supply is a serious issue for South Florida as a result of weather patterns and climate variations. While the area receives nearly 60 in. of rainfall per year, water resources in South Florida are limited as a result of distinct wet and dry seasons. The dry season occurs concurrently with the period of highest population. Concerns generated with the increase in future water demands include availability of water resources, management of wastewater, and compliance with more stringent environmental regulations. The area has only three sources of potable water, the Biscayne and Floridan aquifers and the Atlantic Ocean. The Biscayne Aquifer is the only source of freshwater in this area because the Floridan Aquifer is a brackish source of water. This creates rising concerns regarding the ability of the area to meet future water demands while maintaining the stability of the natural systems.

In early 2007, the South Florida Water Management District imposed stricter limitations on the Biscayne Aquifer in order to protect the Everglades via the Regional Water Availability Rule. The salient features of the Regional Water Availability Rule included the need for future water demands over and above the "base condition water use" to be provided from alternative water sources, defined as desalination of brackish water or saltwater, or replacement of demands with reuse or stormwater. Managed groundwater injection programs designed to recharge well fields may be a solution that addresses most of the potential barriers to reuse.

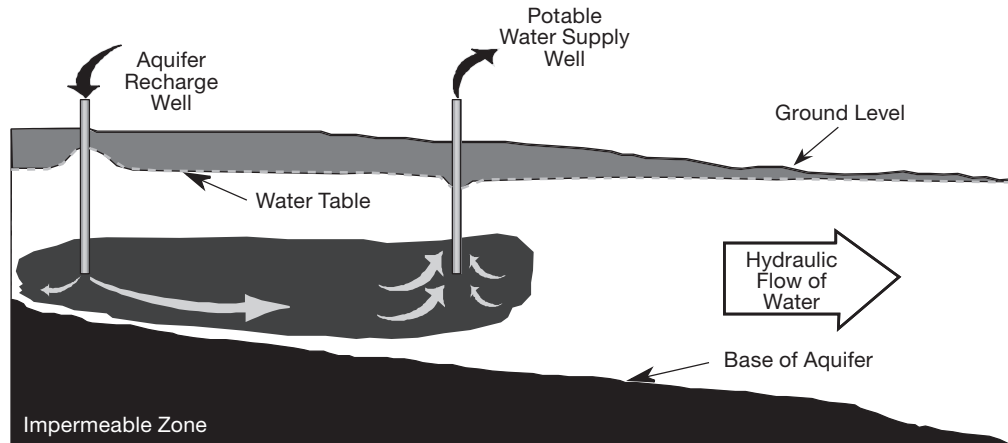

Figure 11-15 Aquifer recharge

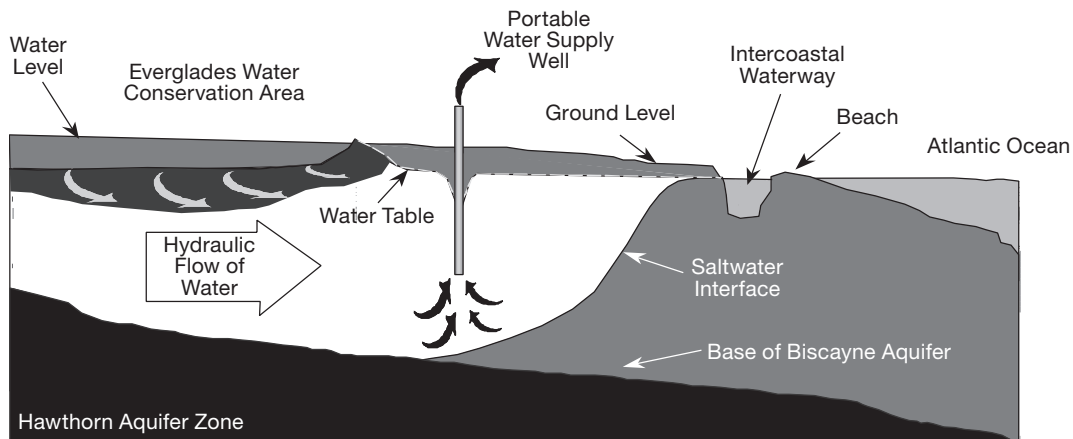

Figure 11-16 Aquifer recharge via flooding

The project evaluated the technical feasibility of using RO to treat wastewater for aquifer recharge or other purposes. The wastewater's quality is an important factor to consider when determining membrane system efficiency. The plan is to treat the wastewater and discharge it to groundwater to enhance source water recovery, thereby preserving or increasing raw water availability in the city's well field. As a result, a research plan was developed to

- Create a program to select and test membranes for use by the city of Pembroke Pines as part of its wastewater treatment plant alternative water supply upgrade.
- Characterize wastewater, concentrate, and finished water quality to develop the design-build package, supplement permitting, and provide data about necessary additional treatment and concentrate issues.
- Conduct bench testing of water quality results compared with membrane manufacturers' claims.
- Conduct pilot testing of candidate membranes provided by proposed suppliers.
- Analyze permeate water quality for post-treatment needs.

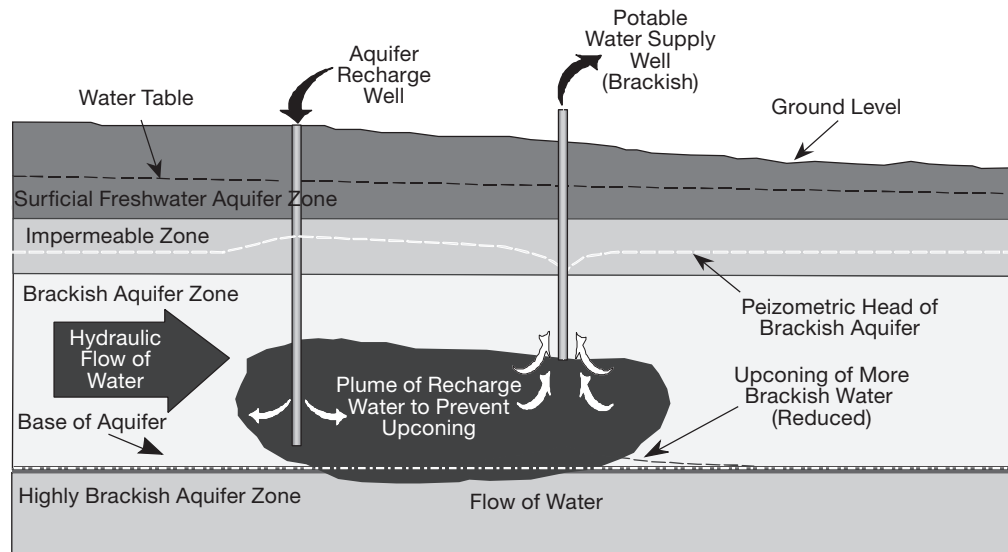

Figure 11-17 Aquifer reclamation to prevent upconing

One goal was to maximize concentrate recovery and develop methods to address disposal of concentrate that cannot be used for other purposes. To do this, the potential membranes will be evaluated and tested. However, an initial determination of aquifer parameters is needed so that the potential membranes can be compared and verified to meet operational parameters. Water quality data are required to determine membrane system options available to the city.

Although salt was not a concern, phosphorous was an important factor. The investigation also considered metals, nitrogen species, and emerging substances of concern. Tables 11-1 to 11-4 indicate that all the membranes successfully removed the regulated constituent when compared with local (Broward County) and state regulatory requirements (FAC) and the actual post-secondary treated wastewater quality measured (SP-1) (Bloetscher et al. 2011).

Table 11-1 outlines the composite results of ongoing phosphorous, coliform, and total suspended solids results that were acquired weekly ($n = 22$). The Broward County limits are shown, as are the Florida Administrative Code (FAC) limits. NS means there is no standard. Table 11-1 shows that for all samples, the results were not detectable. Phosphorous results were below the 0.01 mg/L requirement. Table 11-2 shows the summary of the monthly BOD, COD, TOC and major organic results, along with the Broward County and FAC limits ($n = 6$). Again, all samples were nondetectable. Table 11-3 outlines the quarterly ($n = 3$) trace organic and specific pathogen results, compared to the effluent limits, again showing undetectable quantities. Finally, Table 11-4 shows the metals and nitrogen species compared to the standards, taken on a monthly basis ($n = 6$). Again, the analyses showed undetectable quantities. As a result, the conclusion was that all three membranes appear to be satisfactory for the purposes of this project, pending assurance and demonstration during full-scale operation, of meeting water quality parameters associated with phosphorous (Bloetscher et al. 2011).

Table 11-1 Summary of nutrient and coliform results post RO, UV, and AOP*

Analyte	Units	BC Limit	FAC Limit	Filmtec	Hydranautics	Koch	Post Sec
				SP-4	SP-4	SP-4	SP-1
Avg phosphorous	mg/L	0.01	NS [†]	U	U	U	3.79
Avg turbidity	ntu	10	NS	U	U	U	0.152
Avg total coliforms	cfu/100 mL	1,000	4	U	U	U	389,000
Avg fecal coliforms	cfu/100 mL	800	1	U	U	U	67,125
TSS	mg/L	NS	NS	U	U	U	3.47

Source: Bloetscher et al. 2011

* AOP = Aspect oriented programming

[†] NS = no standard

Table 11-2 Summary of BOC, COD, TOC, and organic results post RO, UV, and AOP

Analyte	Units	BC Limit	FAC Limit	Filmtec	Hydranautics	Koch	Post Sec
				SP-4	SP-4	SP-4	SP-1
BOD	mg/L	5	NS	U	U	U	14.1
COD	mg/L	10	NS	U	U	U	75.2
Oil and grease	mg/L	10	4	U	U	U	1.4
Phenolics	mg/L	0.0001	NS	U	U	U	0.0038
TOC	mg/L	NS	3	U	U	U	11.25

Source: Bloetscher et al. 2011

Table 11-3 Summary of pesticide and pathogen results post RO, UV, and AOP

Analyte	Units	BC Limit	FAC Limit	Filmtec	Hydranautics	Koch	Post Sec
				SP-4	SP-4	SP-4	SP-1
Pesticides							
Azinphos-methyl (guthion)	µg/L	0.1	NS	U	U	U	0.38
Demeton	µg/L	0.1	NS	U	U	U	0.98
Ethyl parathion	µg/L	42	NS	U	U	U	0.22
Malathion	µg/L	0.1	NS	U	U	U	0.23
Chlorinated hydrocarbons							
Hexachlorobutadiene	µg/L	10	NS	U	U	U	0.05
Hexachloroethane	µg/L	10	NS	U	U	U	0.01
Pathogens							
Enterovirus	Infectious units/100 L	1/gal	< 1	U	U	U	109.5
Enumerated <i>Cryptosporidium</i> Oocysts	oocysts/100 L	1/gal	< 1	U	U	U	39
Enumerated <i>Giardia</i> cysts	cysts/100 L	1/gal	< 1	U	U	U	470
Enumerated <i>Giardia</i> cysts, potentially viable	cysts/100 L	1/gal	< 1	U	U	U	352.5
Total enumerated Helminth ova	ova	1/gal	< 1	I	U	U	37.5
Viable Helminth ova	ova/100 L	1/gal	< 1	I	U	U	49

Source: Bloetscher et al. 2011

Table 11-4 Summary of metals and nitrogen species results post RO, UV and AOP

Analyte	Units	BC Limit	FAC Limit	Filmtec	Hydranautics	Koch	SP1
Sodium	ug/L	160,000	160,000	6,400	1,700	2,400	63,333
Antimony	ug/L	6	6	U	U	U	1
Arsenic	ug/L	50	10	U	U	U	1
Barium	ug/L	2,000	2,000	U	U	U	12
Beryllium	ug/L	4	4	U	U	U	0
Cadmium	ug/L	5	5	U	U	U	0
Chromium	ug/L	100	100	U	U	U	1
Lead	ug/L	15	15	I	I	I	1
Mercury	ug/L	2	2	U	U	U	0
Nickel	ug/L	100	100	U	U	U	2
Selenium	ug/L	50	50	U	I	U	1
Thallium	ug/L	2	2	U	U	U	0
Cyanide, total	mg/L	0.2	0.2	U	U	U	0
Fluoride	mg/L	2	4	U	U	U	1
Nitrate as N	mg/L	10	10	0.22	0.27	0.55	15
Nitrate nitrite as N	mg/L	10	10	0.22	0.27	0.55	15
Nitrite as N	mg/L	1	1	I	U	U	0

Source: Bloetscher et al. 2011

The City proposed RO equipment parameters for 6-mgd capacity. The assumptions made extend to the cost comparisons in Table 11-5 including construction cost and operation and maintenance cost based on a 20-year present worth. Table 11-5 also outlines the cost comparisons for the alternative water supply projects available to the City. They are (Bloetscher et al. 2011)

1. Biscayne Aquifer Injection of Reclaimed Water with Lime Softening Potable Water Treatment (study)
2. Residential irrigation reuse system
3. Commercial irrigation reuse system (golf courses and parks)
4. Floridan Aquifer as a potable water supply
5. Floridan Aquifer injection of reclaimed water with RO potable water-system

As can be seen in Table 11-5, a review of the initial capital investment leads to the commercial irrigation reuse alternative having the least capital cost, with the majority of cost tied up in piping infrastructure. The second- and third- ranking capital projects are Biscayne Aquifer injection of reclaimed water and Floridan potable water supply. This is intuitive as the treatment trains are similar but for the necessity of multi-barrier pre- and post-treatment on the wastewater side. This also is somewhat subjective as about 24 percent of the Floridan costs are tied to concentrate disposal wells which, under other circumstances, may be shared with the wastewater treatment plant. The fourth-ranking option is the injection of reclaimed water to the Floridan aquifer with RO potable treatment. This option requires RO prior to injection as well as RO for potable water treatment (due to the saline nature of the Floridan). This "RO in/RO out" scenario is thus twice the cost of either the RO injection or treatment options. Finally, the most capital intensive option is the residential reuse option that requires installation of reclaimed water pipelines throughout the utility.

Table 11-5 Cost comparison of alternate water source options for Pembroke Pines

Components for 6.0 MGD of Finished Product Water	1. Biscayne Aquifer Injection of Reclaimed Water with Lime Softening Potable Water Treatment*	2. Residential Irrigation Reuse System	3. Commercial Irrigation Reuse System	4. Floridan Aquifer as a Potable Water Supply	5. Floridan Aquifer Injection of Reclaimed Water with Reverse Osmosis Potable Water Treatment
Pretreatment Acid/Degasifier	\$ -	\$ -	\$ -	\$ 2,500,000	\$ 2,500,000
Automatic Strainer	\$ 340,000	\$ 340,000	\$ 340,000	\$ -	\$ 340,000
Media Filters	\$ 1,960,000	\$ 1,370,000	\$ 1,370,000	\$ -	\$ 1,960,000
Chlorine Disinfection	\$ 440,000	\$ 310,000	\$ 310,000	\$ 310,000	\$ 750,000
Microfiltration	\$ 6,180,000	\$ -	\$ -	\$ -	\$ 6,180,000
Dechlor/Break Tank	\$ 100,000	\$ -	\$ -	\$ -	\$ 100,000
Reverse Osmosis	\$ 10,000,000	\$ -	\$ -	\$ 10,000,000	\$ 20,000,000
UV-AOP Disinfection System	\$ 2,180,000	\$ -	\$ -	\$ -	\$ 2,180,000
Buildings	\$ 1,980,000	\$ -	\$ -	\$ 1,980,000	\$ 3,960,000
Yard Piping	\$ 4,030,000	\$ 650,000	\$ 650,000	\$ 750,000	\$ 4,780,000
Electrical & Instrumentation	\$ 4,680,000	\$ 390,000	\$ 390,000	\$ 4,680,000	\$ 9,360,000
Existing WWTP Modification	\$ 590,000	\$ 590,000	\$ 590,000	\$ -	\$ 590,000
Sitework	\$ 780,000	\$ 330,000	\$ 330,000	\$ 780,000	\$ 1,560,000
Post Treatment Stabilization	\$ 470,000	\$ -	\$ -	\$ 470,000	\$ 940,000
Recharge Pumps	\$ 390,000	\$ -	\$ -	\$ -	\$ 390,000
High Service Pumps	\$ -	\$ 1,300,000	\$ 1,300,000	\$ 1,300,000	\$ 1,300,000
Floridan Withdrawal Wells	\$ -	\$ -	\$ -	\$ 2,700,000	\$ 2,700,000
Reuse Pipelines (est)	\$ -	\$ 108,000,000	\$ 19,640,000	\$ -	\$ -
Storage tank	\$ -	\$ 1,000,000	\$ 1,000,000	\$ 1,000,000	\$ 1,000,000
Injection Well - class V	\$ 1,300,000	\$ -	\$ -	\$ -	\$ 5,400,000
Injection Well - class I	\$ -	\$ -	\$ -	\$ 10,000,000	\$ 10,000,000
SUBTOTAL	\$ 35,420,000	\$ 114,280,000	\$ 25,920,000	\$ 36,470,000	\$ 75,990,000
Soft Costs - 20%	\$ 7,090,000	\$ 22,860,000	\$ 5,190,000	\$ 7,300,000	\$ 15,200,000
CAPITAL COST TOTAL	\$ 42,510,000	\$ 137,140,000	\$ 31,110,000	\$ 43,770,000	\$ 91,190,000
Estimated Annual Operation Costs					
Labor	\$ 490,000	\$ 179,000	\$ 179,000	\$ 490,000	\$ 980,000
Power	\$ 1,010,000	\$ 78,000	\$ 78,000	\$ 550,000	\$ 1,560,000
Chemicals	\$ 399,000	\$ 200,000	\$ 200,000	\$ 120,000	\$ 519,000
UV Lamps	\$ 95,000	\$ -	\$ -	\$ -	\$ 95,000
Total Annual Cost	\$ 2,000,000	\$ 460,000	\$ 460,000	\$ 1,160,000	\$ 3,160,000
20-Year PW of Annual Costs	\$ 26,300,000	\$ 6,100,000	\$ 6,100,000	\$ 15,300,000	\$ 41,600,000
i = 4.375%					
Present Worth Comparison[†]	\$ 68,900,000	\$ 143,300,000	\$ 37,300,000	\$ 59,100,000	\$ 132,800,000

*Based on no changes to existing water treatment plant.

[†] Excludes all replacement costs at required intervals.

Source: Bloetscher et al. 2011

In comparing the present worth of these options, commercial irrigation reuse remains the lowest total cost. Once the infrastructure is constructed, this type of reuse has very low operational cost relative to the other options. Whereas Biscayne injection and Floridan withdrawal are essentially the same in capital cost, the RO of wastewater in aquifer injection yields a \$10 million lead over Florida withdrawal. This is again due to the necessary operational costs of RO multi-barrier system including membrane filtration and post-treatment with UVAOP. Both of these processes carry a significant electricity burden and neither is required for Floridan withdrawal. The remaining options of Floridan injection, RO in/RO out, and residential reuse have a ranking consistent with the capital cost ranking.

REFERENCES

- Asano, Takashi. 1985. *Artificial Recharge of Groundwater*. Stoneham, Mass.: Butterworth Publishers.
- Bloetscher, Frederick. 2001. Does the Current Knowledge of ASR Answer all the Necessary Questions? *Groundwater Protection Council Annual Conference Proceedings—Reno NV, Oklahoma City, Okla.*: GWPC.
- Bloetscher, F. 2004. Comparisons of Results from Modeling ASR System: Can Modeling Help with Design of ASR Systems? *GWPC Annual Meeting Proceedings*. Oklahoma City, Okla.: GWPC.
- Bloetscher, F., D. Stambaugh, J. Hart, J. Cooper, K. Kennedy, L.S. Burack, A.P. Ruffini, A.J. Cicala, and S. Simenello. 2011. Evaluating Membrane Options for Aquifer Recharge in Southeast Florida, *IDA Journal*, 2(4).
- Bloetscher, F. and G.M. Witt. 1996e. Aquifer Storage and Recovery as a Means of Resource Management: A Summary. *American Water Works Association Annual Conference and Exposition Proceedings—Atlanta, GA, June 1997*, pp. 657–682. Denver, Colo.: American Water Works Association.
- Bloetscher, F. and A. Muniz. 2010. Is ASR a Viable Strategy for Emergency Water Supplies, *Opflow*, 36(8): 24–27.
- Bloetscher, F., A. Muniz, and G.M. Witt. 2005. *Groundwater Injection: Modeling, Risks, and Regulations*. New York, N.Y.: McGraw-Hill.
- Bloetscher, F., C.W. Walker, P.A. Davis, A. Muniz, and W.R. Van Cott. 1996b. Innovative Use of Reclaimed Water to Protect Surficial Drinking Water Supplies. *Florida Water Resource Conference Proceedings—May 7, 1996*.
- Bloetscher, F., C.W. Walker, W.K. Martin, and T.M. Missimer. 1996a. Aquifer Storage and Recovery to Meet Peak Water Demands in Southwest Florida. *Proceedings of CONSERV96*, pp. 825–829. Denver, Colo.: American Water Works Association.
- California Code of Regulations Title 22. 1993. *State of California*, Division 4, Chapter 3.
- Camp, Dresser and McKee (undated). *Wellfield Travel Time Model for Selected Wellfields in Dade, Broward and Palm Beach Counties*, Palm Beach, Fla.: CDM.
- CH2M Hill. 1993. *West Basin Water Recycling Program—Engineering Report for the West Coast Basin Barrier Project, Report for the West Coast Basin Municipal Water District*. Sacramento, Calif.: CH2M Hill.
- Hazen and Sawyer, and Missimer International. 1997. *Hollywood Coastal Salinity Barrier Pilot Phase I Drilling Technical Memorandum, prepared for the City of Hollywood, Fla., 1997*. Boca Raton, Fla.: Hazen and Sawyer.
- Hazen and Sawyer, and Missimer International. 1998. *Hollywood Coastal Salinity Barrier Pilot Project Second Phase Drilling Technical Memorandum*. Prepared for the City of Hollywood, Fla., Aug. 1998. Boca Raton, Fla.: Hazen and Sawyer.
- Muniz, A., M. Tobon, and F. Bloetscher. 2006. Chapter 4 and Chapter 8—Use of Class I Injection Wells Provide an Economical and Environmentally Sound Approach for Effluent and Concentrate Management, How and When Will Impacts be Regulated. In Tsang, C-F, and Apps, J.A., eds. (2006). *International Symposium Underground Injection Science and Technology, Developments in Water Volume 52*. Amsterdam, Netherlands: Elsevier.
- Muniz, A., A.M. Gonzalez, and F. Bloetscher. 2003. Summary of AWWA Survey of ASR Practices in the United States, *Florida Water Resource Conference Proceedings, Tampa, Florida*. St. Cloud, Fla.: FWRC.
- National Research Council. 1998. *Issues in Potable Reuse—The Viability of Augmenting Drinking Water Supplies with Reclaimed Water*. Washington, D.C.: National Academic Press.

- Quinones-Aponte, V., K. Kotun, and J.F. Whitly. 1996. *Analysis of Tests of Subsurface Injection, Storage and Recovery of Freshwater in the Lower Floridan Aquifer, Okeechobee County, Florida*. U.S. Geological Survey, Open File Report 95-765.
- Sloss, E.M., S.A. Geschwind, D.F. McCaffrey, and B. Ritz. 1996. *Groundwater Recharge with Reclaimed Water: An Epidemiological Assessment in Los Angeles County, 1987–1991*. Santa Monica, Calif.: RAND.
- USEPA. 2013. <http://water.epa.gov/type/groundwater/uic/wells.cfm>, accessed 4/29/2012.

This page intentionally blank.

The Future of Groundwater

Over the past 30 years, the AWWA Groundwater Resources Committee has been a significant contributor in providing the water industry with useful and timely information on a variety of groundwater issues. Many of these are technical in nature, as illustrated in this manual M21 *Groundwater*. Other developments made by the committee or members of the committee include seminars on aquifer storage and recovery, riverbank filtration, well drilling and geophysics; webinars on aquifer geophysics and sustainability; a video on the role of groundwater; and publications of well drilling, aquifer injection programs, well standards (AWWA Standard A100), and maintenance of wells. As a result, much of the knowledge of groundwater theory and practice has been captured by AWWA and disseminated in a variety of formats. There are certain topics, such as aquifer geophysics, that are highly specialized with a limited audience. Other topics (ASR and riverbank filtration) are very specific in nature and continue to emerge, but the need for this knowledge is limited.

However, there is an area of groundwater that has become a significant issue across North America that is both needed and timely. This is the issue of managing groundwater supplies in light of overdrafting/mining, and competition and regulatory hurdles that do not protect groundwater sources for the future. The key component to planning the utilization of water supplies is to determine how the hydrologic cycle provides water to the service area (e.g., recharge basin), in what quantities, and with what reliability. The reliability is a risk issue—is the precipitation consistent or are there significant fluctuations that disrupt ongoing basin development. From a practical perspective, sustainable development generally means addressing the environmental, economic, and social concerns. Water quantity and quality issues have significant fiscal impact on the potential users in the basin, and there are unrealized costs and benefits that are often ignored in the current water management framework. Reilly et al. (2009) outlined areas of precipitation

changes throughout the continental United States, and the difference between rainfall and evapotranspiration (ET), which indicated that in many areas the ET rate is higher than the rainfall. The latter means net rainfall for crops and other purposes is not available and demonstrates that high water use is not a sustainable practice. As well, areas that never have surplus amounts of water (deficit areas, including much of the West, upper Midwest bread-basket and East Coast), as compared to the amount of water available for recharge throughout the United States, indicates that most areas have very little water available for recharge. The latter is especially acute in the growing west.

The significance of the issues was outlined in Reilly et al. (2009), where USGS showed regional water-level declines and local water-level declines for changes on a national scale. The mapping shows large areas with water-level decline in excess of 40 ft in at least one *confined* aquifer since predevelopment, or in excess of 25 ft of decline in *unconfined* aquifers since predevelopment. The confined aquifers recharge at very tiny rates, meaning that in most cases, the aquifer is being mined. USGS reports the need for a nationwide effort to organize available information on changes in groundwater storage. Because the withdrawal of this water may appear to be a permanent loss of the resource in the long term, the implication is that water utilities will be acutely affected and that a major effort to understand and recommend solutions to the problem is required. Such a solution cannot be designed without due consideration of the competing water users (power, agriculture, tourism, ecosystems) and the economic impacts on each.

The Groundwater Committee and AWWA should emphasize this controversial topic with the intent of providing guidance to policy makers, the water industry, and water professionals on how to deal with the restrictions in water supplies, and develop solutions to accurately measure available supplies, create better tools to evaluate water mining, and provide solutions to address the problem. This concept is fully in line with the mission of the AWWA Water Resources Sustainability Division, meets the top issue facing the groundwater industry, and is more in line with the active professionals in the field, which may attract planners, geologists, administrators, and engineers to the committee.

Due to recent and ongoing changes resulting from flooding and drought conditions around the United States, the Groundwater Committee will pursue a new approach to bringing this concept into new and existing programs. As municipalities, independently owned utilities, and farmers pursue new sources of water, groundwater is definitely in the forefront of discussions. For example, as surface water supplies in Texas are projected to decrease in availability over a 50-year planning timeline from 13.5 BAF to 13.2 BAF in 2060, groundwater is supplying more resources. Of the 16.1 MAF used in 2008, 60 percent was groundwater (Texas State Water Plan 2012). The Groundwater Resources Committee believes that AWWA members will need a source of expertise and information about groundwater.

Preparing for this extension of the Groundwater Resources Committee's core mission will be the next stage of development. First, the tools that AWWA has recently developed will support new approaches to providing information. In addition to this updated manual M21 *Groundwater*, the committee and AWWA divisions are using new tools such as online file sharing and social media to keep AWWA members abreast of current topics and discussions. Second, the committee will develop a platform of key data requirements to prepare the basic data entry points of overdrafted aquifer information. The data points will be intended to support a collection of major, critical data and information about overdrafted aquifers. Each data point will be assessed from the perspective of the members who need information about overdrafted aquifers. Rather than providing all data that might be available, this platform in its initial phase will provide foundational information and a starting point for utilities to understand the current conditions in overdrafted aquifers. Third, the committee will reach out to new and existing members to involve more

AWWA groundwater professionals in gathering and assessing data about the current status of overdrafted aquifers around the country.

In addition to providing a new tool for AWWA members and its utility partners concerning this area of overdrafted aquifers, targeting this platform allows the Groundwater Resources Committee to establish how well these online communication tools connect with AWWA members. The goals of this program are proposed to

1. Connect AWWA members with expertise in hydrogeology or groundwater-related activities
2. Create online forums and conference workshops/technical sessions to provide up-to-date information about groundwater issues
3. Connect with other organizations for cross-correlation of interests and joint workshops/conferences
4. Reach out to students and young professionals with interests in nontraditional water supply solutions
5. Track groundwater issues, bills, and legislation for AWWA members
6. Connect AWWA groundwater and related communities across the country

REFERENCE

Reilly, T.E., K.F. Dennehy, W.M. Alley, and W.L. Cunningham. 2009. Groundwater Availability in the United States. USGS Circular 1323. Reston, Va.: USGS.

This page intentionally blank.

Glossary of Terms

Anisotropic aquifer is one in which the aquifer formation does not transmit water equally in all directions (i.e., the horizontal and vertical permeability are not equal, causing the water to move preferentially in one direction with respect to the other two). Anisotropy is a property of a water-bearing formation in which hydrologic properties are nonuniform (vertically and/or horizontally).

Aquiclude is a low-permeability geologic unit that forms either the upper or lower boundary of a groundwater flow system. Clay is a typical aquiclude material. This term is not often used in the industry. The term *confining unit* is more commonly used to describe aquiclude formations.

Aquifer is a geologic formation, or part of a group of formations, or a combination of formations, that is saturated and sufficiently permeable to transmit water to wells and springs, in sufficient quantities to be recoverable.

Aquifer storativity is the volume of water added to a unit horizontal area of the aquifer, per unit rise in the water table elevation (i.e., the ability of the aquifer to increase its capacity to store water).

Aquitard is a low-permeability geologic unit that can store groundwater and also transmit it slowly from one aquifer to another. A leaky aquifer formation may be an aquitard. This term is not often used in the industry any longer. The term *semi-confining unit* is more common.

Artesian aquifers occur where water completely fills an aquifer that is overlain by a confining bed; the water in the aquifer is said to be confined.

Artesian wells are wells drilled into confined aquifers that are under pressure. In artesian wells, the piezometric level is above the ground surface, meaning that water could flow to the surface unaided.

Capacity is the rate of flow delivered by a pump, in units such as gallons per minute, cubic feet per second, or barrels per hour. To calculate the power needed or the size

of prime mover required to produce a desired capacity, the rate of flow and total dynamic head must be determined.

Capillary fringe is the subzone between the unsaturated and saturated zones. The capillary fringe occurs when a film of water clings to the surface of rock particles and rises in small-diameter pores against the pull of gravity.

Cavitation is the formation and collapse of water vapor bubbles in the flowing water.

Coefficient of permeability is a measure of the ease with which fluid is transported through a porous matrix (see hydraulic conductivity).

A **confined aquifer** is one that is overlain by a confining unit, the water in the aquifer is said to be confined. Typically clay or another impervious layer separates confined aquifers from the surface. Most confined aquifers are under some amount of pressure but not always.

A **confining unit** is a low-permeability geologic unit that forms either the upper or lower boundary of a groundwater flow system. Clay is a typical confining unit material.

Dynamic head is the resistance to flow produced by a system. Dynamic head is equal to the sum of static head, velocity head, and friction head.

Effective pore space is an indication of how much of the void space within the rock or soil is capable of transmitting water. This is important because some rock formations may have considerable pore (or void) space, but because the pores are not interconnected, the rock or soil may have difficulty transmitting water.

Evaporation is the transformation of water from the liquid phase to a vapor phase in the atmosphere.

Evapotranspiration is the combination of evaporation and transpiration. Water less than 4 ft below the ground surface may be subject to evapotranspiration.

Flowing artesian wells occur when the water level in an artesian well stands above the land surface.

Groundwater is defined as water contained in interconnected pores located either below the water table in an unconfined aquifer or in a confined aquifer.

Hydraulic conductivity, commonly denoted as *K*, is a measure of the ease with which fluid is transported through a porous matrix (also called *coefficient of permeability*). Hydraulic conductivity is a hydraulic property given in terms of a unit cube of material; it should not be confused with transmissivity, which is another hydraulic property, but is given in terms of a unit prism of an aquifer (see also *transmissivity*).

Hydrologic cycle is the movement of water in the environment wherein water falls to the surface as rainfall, runs off over land to water bodies and/or infiltrates into the groundwater, and returns to the atmosphere via evaporation/transpiration, and returns as rainfall. This is best demonstrated in Figure 1-1 and discussed in chapter 1 of this manual.

Hydraulic gradient is a measure of the vertical change of the aquifer over a given distance from a stationary base (i.e., the slope of the aquifer formation).

An **isotropic aquifer** is one in which the formation transmits water equally in all directions within the aquifer formation (generally considered to be a theoretical, ideal situation, rarely encountered in nature).

A **karstic formation** is a geological formation shaped by the dissolution of a layer or layers of soluble carbonate rock like limestone, dolomite, or gypsum.

Net positive suction head (NPSH) is the amount of pressure that prevents water from vaporizing, which can cause cavitation (the formation and collapse of water vapor bubbles in the flowing water) and damage a pump.

Piezometric surface is the level to which water will rise in an aquifer under the influence of surface conditions. In a water table aquifer, the piezometric surface is the water table level. In a confined aquifer, the piezometric section may be significantly above the top of the rock formation if the aquifer is under pressure.

Potential evapotranspiration is the amount of evapotranspiration that would occur, assuming the soil moisture was adequate at

all times. During drought conditions evaporation cannot occur, and so actual evapotranspiration may be less. Because of the disparity among the rainfall throughout the year, atmospheric temperatures, and the freeze/thaw cycle, the actual evapotranspiration in the winter months is typically less than summer months.

Potentiometric surface is the imaginary line where a given reservoir of fluid will equalize when allowed to flow.

Recharge areas are areas of porous surface soil that have a downward flow of percolating precipitation.

Screen aperture is the same as the slot size of a slotted well screen.

A **semi-confining unit** is a low-permeability geologic unit that can store groundwater and also transmit it slowly from one aquifer to another. A leaky aquifer formation may be a semi-confining unit.

Specific capacity is the yield of a well, usually expressed in gallons per minute per foot of drawdown.

Specific discharge potential is the amount of water that an aquifer could discharge given its hydraulic conductivity and piezometric head.

Specific yield is the hydraulic property describing the available storage of a unit cube of material; it should not be confused with the storage coefficient, which is another hydraulic property describing available storage, but is given in terms of a unit prism of aquifer (see also *storage coefficient*).

A **spring** is the result of an aquifer being filled to the point that the water spills over the land surface.

Static discharge head is the distance measured vertically from the pump centerline to the water level in storage.

Static head is the static suction head plus the static discharge head (Figure 6-1). To calculate static head, all measurements in pumping are vertical and the maximum drawdown is used as a reference. Measurements above this level are positive; those below, negative. The same measuring procedure can be used for both submersible and surface-mounted pumps.

Static suction head is the vertical measurement, in feet, of the distance from the water level in a well to the pump centerline.

Storage coefficient is the hydraulic property describing the available storage of a unit prism of aquifer; it should not be confused with the specific yield, which is another hydraulic property describing available storage, but is given in terms of a unit cube of material (see also *specific yield*).

Submergence, commonly denoted as S , is measured from water level to introduction of air.

Subsidence is the motion of the Earth's surface as it shifts downward and can be caused by groundwater development from unconsolidated or highly friable rock formations

Transmissivity, commonly denoted as T , is the aquifer characteristic that is defined by the rate of flow per unit width through the entire thickness of an aquifer per unit gradient. This is valid only in two-dimensional flow. Transmissivity is a hydraulic property given in terms of a unit prism of an aquifer; it should not be confused with hydraulic conductivity, which is another hydraulic property, but is given in terms of a unit cube of material (see also *hydraulic conductivity*). Transmissivity can be found by multiplying the hydraulic conductivity (K) by the saturated aquifer thickness.

Transpiration is the process in which plants absorb water from the soil and release it to the atmosphere through their leaves.

Underreaming is the process of enlarging a section of wellbore beneath a restriction. The most frequently encountered restrictions are the internal diameter (ID) of the casing and the size of the wellhead. Both limit the maximum outside diameter (OD) of the tools that can pass through.

Velocity head is the height through which a buoy must fall freely to attain its velocity. In most cases, the velocity head is small and can be ignored. Table 6-1 provides a way to determine velocity head.

A **Venturi diffuser** is a device that uses the parabolic converging section to centralize the flow from the nozzle into the Venturi throat.

Viscosity combines with the fluid density to form kinematic viscosity, which is important in determining the hydraulic conductivity of the soil or rock matrix.

Void space is the pore space within the soil or rock matrix that does not contain solid material.

Water horsepower is the work required to lift a weight of water to a defined height per unit of time (usually a second or a minute).

This page intentionally blank.

Index

Note: *f.* indicates figure; *t.* indicates table, *n.* indicates (foot)note

- Absorption and adsorption, 217
- Activated carbon, 217–218
- Advanced oxidation, 211, 211*f.*
- Aeration, 207–208
 - diffused, 208
 - forced or induced draft, 208
 - natural draft, 208, 208*f.*
 - by packed-tower aerators (air strippers), 208, 209*f.*
- Airlift pumps, 151–152, 152*f.*, 152*t.*, 154*t.*
- American Water Works Association (AWWA)
 - focus on overdrafting and future supply of groundwater, 261–263
 - Groundwater Committee, 261–263
 - Standard A100, 107, 122
 - and well construction materials, 97
- Amoebas, 195
- Anisotropic aquifer, defined, 265
- AQTESOLV software, 67–68
- Aquiclude, defined, 265
- Aquifer management. *See* Management and protection
- Aquifer parameters, 51–52
 - available storage units, 64
 - capillarity, 58, 59*f.*, 60*t.*
 - hydraulic conductivity, 57–58, 58*f.*, 60–61, 61*f.*, 266
 - hydraulic gradient, 51, 55–56, 55*f.*, 56*f.*, 57, 57*n.*, 266
 - hydraulic head, 51, 54–55, 55*f.*
 - porosity, 51, 52, 53*f.*, 54*t.*
 - specific retention, 51, 53–54, 53*f.*, 54*t.*
 - specific yield, 51, 53–54, 53*f.*, 54*t.*
 - storage coefficient, 64–65, 65*f.*, 66–67
 - theoretical cube, 51, 52*f.*
 - transmissive capacity units, 64
 - transmissivity, 51, 62–64, 63*f.*, 64*f.*
 - unsaturated flow, 59*f.*, 60
- Aquifer reclamation, 247
 - Hollywood (Fla.) salinity barrier project, 248, 249*f.*, 250*f.*
 - West Coast Basin Barrier Project (Southern California), 248–250, 251*f.*
 - See also* Artificial aquifer creation and recharge
- Aquifer storage and recovery (ASR), 43, 241–242, 242*f.*
 - Collier County (Fla.) use as water management tool, 242, 243*f.*
 - Peace River (Fla.) project (case study), 242–247, 244*f.*, 245*f.*, 246*f.*, 247*f.*
 - See also* Artificial aquifer creation and recharge
- Aquifer storativity, defined, 265
- Aquifers, 7
 - analysis of performance test data, 67–76
 - anisotropic, 265
 - collecting water-level test data, 67
 - cone of depression, 8, 9*f.*
 - confined, 7, 8, 8*f.*, 68, 265
 - confining beds, 7–8, 8*f.*
 - defined, 265
 - drawdown, 8
 - drawdown method (analysis of test data), 69–71, 70*f.*, 71*t.*, 72*f.*
 - electric water-level sounders, 66
 - hypothetical performance test setup, 68–69, 69*f.*
 - impermeable-barrier effect and drawdown method, 72–73, 73*f.*, 74*f.*
 - isotropic, 266
 - leaky, 69
 - microflora in, 170
 - recharge effect and drawdown method, 73, 74*f.*, 75*f.*
 - recovery method (analysis of test data), 75–76
 - sonic water-level sounders, 66
 - specific-capacity method (analysis of test data), 76
 - straight-line (Jacob) solution (drawdown method), 71, 72*f.*
 - tape method of water-level measurement, 66
 - transducer-based water-level measurement, 66–67
 - type-curve solution (drawdown method), 70–71, 72*f.*
 - unconfined, 7, 8*f.*, 69
 - See also* Artificial aquifer creation and recharge; Groundwater; Wells
- Aquitard, defined, 265
- Arsenic, 199–200
- Artesian aquifers, defined, 265
- Artesian wells, defined, 265
- Artificial aquifer creation and recharge, 252
 - Pembroke Pines (Fla.) indirect potable reuse project (case study), 252–258, 255*t.*, 256*t.*, 257*t.*
 - recharge, 252, 253*f.*
 - recharge by flooding, 252, 253*f.*

- recharge to prevent upconing, 252, 254*f.*
- Artificial recharge, 43
- ASR. *See* Aquifer storage and recovery
- Axial flow pumps, 149

- Bacteria, 196–197
 - gram-negative, 196
 - iron, 170–171
 - sulfur-depositing, 170
 - sulfur-oxygenating, 170–171
 - sulfur-reducing, 170
- Bacteriophages, 197
- Bored wells, 80–81, 95*t.*
- Borehole Geophysics Applied to Groundwater Investigations*, 22–23
- Broward County (Fla.) source water protection areas, 38–40, 39*f.*

- Cake filters, 217
- Calcium carbonate precipitation potential (CCPP), 219–220
- Calcium carbonate saturation index. *See* Langelier saturation index
- Capacity, defined, 265
- Capillary diameter, 58, 59*f.*, 60*t.*
- Capillary fringe, 7, 7*f.*, 58
 - defined, 265
- Capillary gradient, 60, 61*f.*
- Carbon dioxide, 194
- Carbonic acid, 194
- Carryover storage, 43. *See also* Aquifer storage and recovery
- Cavitation, defined, 265
- Centrifugal pumps, 137–145, 144*f.*, 145*t.*, 154*t.*, 157
- Chloramines, 221
- Chlorine
 - in disinfection, 221
 - in oxidation, 209, 210*f.*
- Chlorine dioxide, 222
- Chromium, 199
- Coefficient of permeability
 - defined, 265
 - See also* Hydraulic conductivity
- Coefficient of transmissibility. *See* Transmissivity
- Collier County (Florida) Water–Sewer District, 178
 - ASR use as water management tool, 242, 243*f.*
 - well field plugging and microbiological fouling (case study), 178–181, 180*f.*
- Confined aquifer, defined, 265
- Confining unit, defined, 265
- Conjunctive use, 43
- Contaminants and contamination, 16
 - and abandonment of supply, 41, 42
 - amoebas, 195
 - bacteria, 196–197
 - and blending strategy, 41
 - chemical, 197–204
 - chemical, sources of, 203–204, 204*t.*
 - chlorine by-products, 209
 - endocrine disruptors, 202
 - flow from surface water to aquifer, 203, 204*f.*
 - haloacetic acids (HAAs), 201
 - information on, 31
 - inorganic chemicals, 197, 198–200
 - from leaking fuel tanks, 36, 37*f.*
 - management of, 41–42, 42*f.*
 - MCLs for selected chemicals, 197, 198*t.*
 - microorganisms, 195–197
 - minerals, 197, 199–200
 - movement within aquifer, 204
 - nitrogen, 197, 198
 - nitrosamines, 201–202
 - and nonpotable use, 41, 42
 - organic chemicals, 197
 - pesticides, 197, 201, 201*t.*
 - pharmaceutically active substances (PASs), 202–203, 203*t.*
 - protozoans, 195–196
 - radionuclides, 197, 200
 - and pump and treat strategy, 41, 42
 - self-contamination, 36
 - total dissolved solids (TDS), 197, 199
 - trihalomethanes (THMs), 201, 209
 - viruses, 196–197
 - volatile organic compounds (VOCs), 197, 200
 - and waterborne illness, 36
 - and well relocation, 41, 42
 - See also* Groundwater quality
- Core transfers, 43
- Corrosion, 218
 - assessing water corrosivity, 220
 - and calcium carbonate precipitation potential (CCPP), 219–220
 - common treatment approaches, 220–221
 - conditions for, 218
 - and Langelier saturation index (LSI), 218–219
 - and Ryznar stability index (RSI), 219
- Coxsackie virus, 197
- Cryptosporidium*, 195–196, 221

- Darcy's law, 57, 60
- Deep-well turbine pumps, 146–147, 148*f.*, 154*t.*, 157, 159
- Desulfovibrio*, 196
- Direct conjunctive use, 43
- Discharge head, 157
- Drawdown method (analysis of aquifer test data), 69–70, 70*f.*, 71*t.*
 - and impermeable-barrier effect, 72–73, 73*f.*, 74*f.*
 - and recharge effect, 73, 74*f.*, 75*f.*
 - straight-line (Jacob) solution, 71, 72*f.*
 - type-curve solution, 70–71, 72*f.*
 - See also* Step-drawdown test

- Drilled wells, 82–83, 95*t.*
 alignment graph, 114, 116*f.*
 bail-down method, 89–90
 cable-tool method, 83–84, 84*f.*
 cable-tool method, casing for, 98–99
 caisson method, 89
 California method, 88–89
 down-the-hole method, 85–86, 86*f.*
 drift (horizontal deviation) calculation,
 113–114, 115*f.*, 116*f.*
 drill-hole characteristics, 93
 drilling fluid materials, 97–98
 drilling test sheet, 114, 114*t.*–115*t.*
 drive shoes, 98
 dual-rotary method, 87–88, 88*f.*
 effective and inside diameters (diagram),
 114, 117*f.*
 and formation recognition, 83
 gravel-wall, 90–91, 91*f.*
 jetting method, 89
 measuring drill alignment, 112–114, 113*f.*,
 114*t.*–115*t.*, 115*f.*, 116*f.*, 117*f.*
 and north-south/east-west planes, 114
 plumbness graph, 114, 116*f.*
 plummets and plumb lines in drilling,
 112–113, 113*f.*
 reverse-circulation rotary method, 86–87, 87*f.*
 rotary method, 84–84, 85*f.*
 rotary method, casing for, 99
 two-piece method, 90
 under-reamed method, 89
 well diagram, 114, 115*f.*
- Driven wells, 81–82, 95*t.*
- Duck botulism, 195
- Dug wells, 80, 81*f.*, 95*t.*
- Dynamic head, 135
 defined, 265
 total, 155
- ECHO virus, 197
- Effective pore space, defined, 265
- Elkhart (Indiana) Department of Public Works
 and Utilities, 182
 life-cycle cost (LCC) analysis of wells,
 186–187
 South Well Field plugging and
 microbiological fouling (case study),
 182–187, 183*t.*
 well decommissioning and abandon-
 ment, 187
- Endocrine disruptors, 202
- Enterobacter*, 196
- Environmental Protection Agency (EPA). *See* US
 Environmental Protection Agency
- Escherichia coli*, 196
- Estuaries, 4
- ET. *See* Evapotranspiration
- Evaluation of groundwater conditions, 15–16
 changes affecting, 18
 contaminant information, 31
 contaminants, 16
 documentation, 30–31, 31*f.*, 32*f.*
 drilling permits, 30
 and existing water rights, 18
 field logistics and documentation, 30–32
 hydrogeologic cross sections, 30, 31*f.*
 land costs, 30
 and land use, 16–17
 mineral quality, 16
 and pollution control, 16
 predevelopment and predicted contour
 maps, 30, 32*f.*
 professional services, 30
 and published reports, 17–18
 reports and legal documents, 30
 supply and usage information, 31
 water quality considerations, 16
See also Groundwater exploration
- Evaporation, defined, 265
- Evapotranspiration, 2, 2*f.*, 3, 3*f.*, 4*f.*
 defined, 266
 potential, 266
 and sustainability, 44
- Exploration. *See* Groundwater exploration
- Filtration, 215–217
 cake filters, 217
 granular, 216, 216*f.*
 and oxidation in iron and manganese
 removal, 215
 pressure filters, 216, 216*f.*
- Flow
 direction, 6
 as related to topography, 8, 9*f.*
 velocity, 6
- Flowing artesian wells, defined, 266
- Fluoridation, 222
- Fluoride, 199
- Fouling of wells. *See* Microbiological fouling;
 Well performance problems
- Friction head, 135–136, 138*t.*–141*t.*, 142*t.*–143*t.*
- Gallionella*, 196
- Giardia lamblia*, 195–196
- Granular activated carbon (GAC), 218
- Granular filtration, 216, 216*f.*
 backwashing, 216, 217*f.*
- Groundwater
 calculating movement of, 56, 56*f.*
 climate impacts on, 11–12
 defined, 266
 under direct influence of surface water
 (GWUDI), 40
 as fossil water, 11
 and land surface subsidence, 10
 mining and overdrifting, 47–48, 261–263
 as percentage of water supplies
 (U.S.–Canada), 1

- and surface events, 1
- See also* Aquifers; Wells
- Groundwater and Wells*, 108
- Groundwater exploration, 18–19, 26
 - acoustic logging in, 25
 - aerial photos and other tools in, 19
 - aquifer testing, 26
 - borehole geophysical logging, 22–26
 - caliper logging in, 23
 - drilling permits, 30
 - electrical resistivity in, 19–21, 20f.
 - electrical resistivity logging in, 23–24, 25f.
 - exploratory drilling, 26
 - fluid logs in, 25–26
 - gamma logs in, 24
 - gamma-gamma (radioactive tracer) logs in, 24
 - geophysical methods without drilling, 19–22
 - hydrophysical logging in, 26
 - lithologic logging in, 26–27
 - log suites, 26, 27f.
 - neutron logging in, 24–25
 - seismic refraction and reflection in, 19, 21–22, 22f.
 - single-point resistance logs in, 24, 25f.
 - spontaneous potential (SP) logging in, 24
- Groundwater Foundation, 37
- Groundwater management. *See* Management and protection
- Groundwater Guardian Program, 37
- Groundwater modeling, 127–128
 - analog, 127
 - applications of, 132
 - calibration, 130
 - of contaminant transport, 131
 - data needs, 127, 129–130
 - and flow in fractured media, 131
 - information sources, 133
 - limitations of, 131–132
 - mathematical, 127–133
 - objectives, 128
 - physical-scale, 127
 - published models, 132–133
 - regulations and guidelines, 132
 - as representation of hydrogeological system, 127
 - solute-transport models, 127
 - steps in, 128, 129f.
 - uncertainty in, 131–132
 - variables, 127
 - verification, 131
- Groundwater quality, 191
 - biological contaminants, 195–197
 - chemical constituents, 191, 192t.–193t.
 - chemical contaminants, 197–204, 198t., 201t., 203t., 204f., 204t.
 - evaluating, 16, 27–28
 - and gases, 194
 - and hardness, 194, 211
 - monitoring wells, 28
 - multiple-completion monitoring wells, 28, 29f.
 - and pH, 192
 - sampling and analysis, 28–29, 29f.
 - and temperature, 192
 - See also* Contaminants and contamination
- Groundwater recharge and storage, 239
 - injection wells (Classes I–VI), 240–241
 - See also* Aquifer reclamation; Aquifer storage and recovery; Artificial aquifer creation and recharge
- Groundwater treatment, 207
 - activated carbon, 217–218
 - advanced oxidation, 211, 211f.
 - aeration, 207–208
 - cake filters, 217
 - chloramines (as disinfectants), 221
 - chlorine (in disinfection), 221
 - chlorine (in oxidation), 209, 210f.
 - chlorine dioxide (as disinfectant), 222
 - for corrosion, 218–221
 - diffused aeration, 208
 - disinfection, 221–222
 - filtration, 215–217
 - fluoridation, 222
 - forced or induced draft aeration, 208
 - granular activated carbon (GAC), 218
 - granular filtration, 216, 216f.
 - hydrochloric acid (in disinfection), 221
 - hydrogen peroxide and ozone, 211
 - hypochlorite (in disinfection), 221
 - ion exchange in iron and manganese removal, 215
 - ion-exchange softening, 213, 215f.
 - for iron and manganese, 215
 - lime–soda ash softening, 212, 213f., 214f.
 - membrane processes, 212, 222–224, 224f.
 - natural draft aeration, 208, 208f.
 - oxidation, 209–211
 - oxidation/filtration in iron and manganese removal, 215
 - ozone (as disinfectant), 222
 - ozone (in oxidation), 210
 - packed-tower aerators (air strippers), 208, 209f.
 - potassium permanganate, 210
 - powdered activated carbon (PAC), 218
 - pressure filters, 216, 216f.
 - sequestering of iron and manganese, 215
 - softening, 212–213
 - UV light, 211, 212f.
 - UV light and hydrogen peroxide, 211, 211f.
 - UV light and ozone, 211
- Haloacetic acids (HAAs), 201
- Handbook for Groundwater and Wellhead Protection*, 38
- Handbook of Ground Water Development*, 108

- Hardness, 194, 211
- Head loss, 136, 138*t.*–141*t.*, 142*t.*–143*t.*
- Head. *See* Discharge head; Dynamic head; Friction head; Head loss; Hydraulic head; Net positive suction head; Static head; Static suction head; Total head; Velocity head
- Hepatitis A, 197
- Hollywood, Florida, 248
- salinity barrier project (aquifer reclamation case study), 248, 249*f.*, 250*f.*
- Horizontal wells. *See* Riverbank filtration
- Hydraulic conductivity, 7–8, 57, 58*f.*, 60–61, 61*f.*
- defined, 266
- in rock, 57–58, 59*f.*
- Hydraulic gradient, 51, 55, 55*f.*, 57
- calculating, 56, 56*f.*
- defined, 266
- terminology and symbols, 57*n.*
- Hydraulic head, 51, 54–55, 55*f.*
- Hydrochloric acid
- in disinfection, 221
- in treatment of microbiological fouling, 172
- Hydrogen peroxide
- and ozone, 211
- and ultraviolet light, 211, 211*f.*
- Hydrogen sulfide, 194
- Hydrologic cycle, 2, 2*f.*
- defined, 266
- evapotranspiration, 2, 2*f.*, 3, 3*f.*, 4*f.*
- precipitation, 2, 2*f.*, 4, 5*f.*
- surface water, 2, 2*f.*, 5
- Hypochlorite
- in disinfection, 221
- in treatment of microbiological fouling, 172
- Impulse pumps, 151–153, 152*f.*, 152*t.*, 153*f.*, 154*t.*
- Infiltration, 6
- Infiltration galleries. *See* Riverbank filtration
- Initial infiltration, 6
- Inorganic chemicals, 197, 198–200
- Instrumentation and Control* (M2), 158
- Intergovernmental Panel of Climate Change (IPCC), 11–12
- Intermediate zone, 6, 7*f.*
- Ion exchange
- in iron and manganese removal, 215
- in softening, 213, 215*f.*
- Iron and manganese
- ion exchange in removal of, 215
- oxidation and filtration in removal of, 215
- sequestering of, 215
- treatment, 215
- Isotropic aquifer, defined, 266
- Jet pumps, 152–153, 153*f.*, 154*t.*, 157
- Karstic formation, defined, 266
- Klebsiella*, 196
- Land surface subsidence, 10
- areas experiencing (U.S.), 10, 11*f.*
- estimating, 10
- Langelier saturation index (LSI), 218–219
- Lead, 199
- Legionella*, 196
- Lime–soda ash softening, 212, 213*f.*, 214*f.*
- co-location with nanofiltration, 222–223
- Locating groundwater supplies. *See* Groundwater exploration
- Management and protection, 35–36
- artificial recharge, 43
- AWWA focus on overdrafting and future supply of groundwater, 261–263
- conjunctive use, 43
- and contamination, 36
- contamination management, 41–42, 42*f.*
- cross-jurisdictional cooperation, 40
- future of, 49
- and Groundwater Guardian Program, 37
- integrated, 49
- regional cooperation, 42–43
- regulatory level, 36–38
- Source Water Assessment Programs (SWAPs), 37
- source water protection programs, 36–40, 37*f.*, 39*f.*
- strategies, 40–41, 41*f.*
- water marketing, 43
- and water rights conflicts, 48
- water transfers, 43
- water wheeling, 43
- See also* Record keeping; Sustainability
- Manual of Water Well Construction Practices*, 108
- Mean sea level, 54
- Membrane processes, 222
- cleaning and flushing, 223
- in dual filtration, 223
- feed pumps for, 223
- membrane layers, and flow through, 223–224*f.*
- nanofiltration, 222–223
- recovery ranges, 223–224
- reverse osmosis, 223, 224*f.*
- skids, 223
- Methane, 194
- Methyl tertiary butyl ether (MTBE), 200
- Microbiological fouling, 169
- acidification in treatment of, 172–173
- and aquifer microflora, 170
- and biofilms, 170–171
- and biological activity reaction test (BART), 171
- blended chemical heat treatment (BCHT) of, 173
- cable-tool surging in treatment of, 172
- chemical treatment of, 172

- chlorination in treatment of, 172
- CO₂ injection in treatment of, 173
- detecting, 171
- environmental issues in treatment of, 174
- gas-charge percussive techniques in treatment of, 173–174
- heat-amended chemical treatments of, 173
- hydrochloric acid in treatment of, 172
- hydrogen peroxide in treatment of, 172
- hypochlorite in treatment of, 172
- and iron bacteria, 170–171
- and MAG test, 171
- physical agitation in treatment of, 172
- and *Pseudomonas*, 170–171
- sonar jetting in treatment of, 173–174
- and sulfur-depositing bacteria, 170
- and sulfur-oxygenating bacteria, 170–171
- and sulfur-reducing bacteria, 170
- surging in treatment of, 172
- symptoms of, 169–170
- Thiotrix*, 170–171
- treatment approaches, 172–174
- ultra acid base process in treatment of, 173
- Microorganisms, 195–197
- Minerals, 197, 199–200
- Mixed flow pumps, 149, 154*t.*
- Modeling. *See* Groundwater modeling
- MODFLOW, 17, 127
- MTBE. *See* Methyl tertiary butyl ether

- Naegleria fowleri*, 195
- Nanofiltration, 222–223
- National Geodetic Vertical Datum of 1929, 54
- NDMA, 201–202
- Net positive suction head (NPSH), 137, 159
- defined, 266
- Nitrates and nitrites, 198
- Nitrogen, 197, 198
- total, 198
- Nitrosamines, 201–202
- North American Vertical Datum of 1988 (NAVD88), 54
- Norwalk virus, 197
- NSF International standards (well construction materials), 97

- Ohm's Law, 23–24
- Option transfers, 43
- Organic chemicals, 197
- Oxidation, 209–211
- and filtration in iron and manganese removal, 215
- Oxygen, in groundwater, 194
- Ozone, 210
- and hydrogen peroxide, 211
- and ultraviolet light, 211

- PAC. *See* Powdered activated carbon
- PASs. *See* Pharmaceutically active substances

- Peace River Manasota (Florida) Regional Water Supply Authority, 242
- ASR project (case study), 242–247, 244*f.*, 245*f.*, 246*f.*, 247*f.*
- Pembroke Pines, Florida, 252
- aquifer recharge project (case study), 252–258, 255*t.*, 256*t.*, 257*t.*
- Pesticides, 197, 201, 201*t.*
- pH, 192
- Pharmaceutically active substances (PASs), 202–203, 203*t.*
- Piezometric surface, defined, 266
- Plugged wells
- Collier County (Fla.) well field (case study), 178–181, 180*f.*
- Elkhart (Ind.) South Well Field (case study), 182–187, 183*t.*
- iron and manganese plugging, 167
- particulate plugging, 167
- rehabilitation vs. replacement (cost/benefit analysis), 175–178, 176*t.*
- Venice (Fla.) well field (case study), 181–182, 182*f.*
- and well efficiency monitoring, 175, 176*f.*
- and well performance history, 177, 177*f.*
- Plunger pumps. *See* Reciprocating pumps
- Porosity, 51, 52, 53*f.*, 54*t.*
- Positive-displacement pumps. *See* Rotary-displacement pumps
- Potassium permanganate, 210
- Potential evapotranspiration, defined, 266
- Potentiometric surface, defined, 266
- Powdered activated carbon (PAC), 218
- Precipitation, 2, 2*f.*, 4, 5*f.*
- Precoat filters. *See* Cake filters
- Propeller pumps, 149, 154*t.*
- Protozoans, 195–196
- Pseudomonads, 196
- Pseudomonas aeruginosa*, 196
- Pumps and pumping. *See* Well pumps and pumping

- Radial wells, 92–93, 92*f.*, 95*t.*
- yield, 127
- Radionuclides, 197, 200
- Radon, 200
- Recharge, 6
- availability of (US), 45–47, 46*f.*
- Recharge areas, 6
- defined, 266
- Reciprocating pumps, 145, 146*f.*, 154*t.*
- Record keeping, 227
- design and construction records, 227–230, 228*f.*, 229*f.*, 231*f.*, 232*f.*
- differential between well and aquifer water levels, 237
- filing and maintenance, 238
- monthly operation report, 236*f.*
- monthly pumpage, 235, 235*f.*, 236*f.*

- pump data, 230, 233*f.*, 234*f.*
 - specific capacity, 237
 - water levels, 237
 - water temperature, 237
 - well abandonment, 238
 - well acceptance and pumping test, 235
 - well completion report, 231*f.*
 - well design, 228*f.*
 - well drilling permit, 229*f.*
 - well maintenance, 238
 - well summary information, 232*f.*
- Recovery method (analysis of aquifer test data), 75
 - straight-line solution, 75–76
 - type-curve solution, 75
- Reoviruses, 197
- Replacement (in-lieu) conjunctive use, 43
- Reverse osmosis, 223, 224*f.*
- Riverbank filtration, 93–94, 94*f.*
- Rock and soil grain-size classification (USGS), 97, 97*t.*
- Rotary pumps, 149, 154*t.*, 157
- Rotary-displacement pumps, 149, 150*f.*, 154*t.*, 157
- Rotary-gear pumps, 149, 151*f.*, 154*t.*
- Rotaviruses, 197
- Ryznar stability index (RSI), 219

- Safe Drinking Water Act (SDWA), 16
 - and Source Water Assessment Programs (SWAPs), 37
 - and source water protection programs, 36–38
 - and well construction materials, 97
- Salmonella*, 196
- Saturated zone, 6, 7*f.*
- Schlumberger array, 19–21, 20*f.*
- Screen aperture, defined, 266
- Screw pumps, 149
- Seasonal storage, 43
- Selenium, 199
- Semi-confining unit, defined, 266
- Shigella*, 196
- Softening, 212
 - ion-exchange, 213, 215*f.*
 - lime–soda ash, 212, 213*f.*, 214*f.*
- Soil zone, 6, 7*f.*
- Solvents, 200
- Sorption, 217
- Source Water Assessment Programs (SWAPs), 37
- Source water protection
 - four-zone system (example), 38–40, 39*f.*
 - and land rights, 38
 - and monitoring, 38
 - programs, 36–38
 - regulatory and nonregulatory options, 38
 - steps in, 38
- Specific capacity
 - defined, 266
 - and evidence of physical problems, 166
 - method (analysis of aquifer test data), 76
 - record keeping, 237
 - in well performance evaluation, 162
- Specific discharge potential, defined, 266
- Specific retention, 51, 53–54, 53*f.*, 54*t.*
- Specific weight of water, 136
- Specific yield, 51, 53–54, 53*f.*, 54*t.*
 - defined, 266
 - in well design, 122
- Spiral pumps, 149
- Spot transfers, 43
- Spring, defined, 266
- SRSV, 197
- Static discharge head, defined, 266
- Static head, 135, 136*f.*
 - defined, 266–267
- Static suction head, 135
 - defined, 267
- Step-drawdown test, 121, 162. *See also* Drawdown method
- Storage coefficient, 64–65, 65*f.*
 - defined, 267
 - field testing, 65–67
- Strontium-90, 200
- Submergence, defined, 267
- Submersible pumps, 147, 154*t.*, 157, 160
- Subsidence, defined, 267
- Summary Appraisals of the Nation’s Ground-Water Resources, 17
- Surface water, 2, 2*f.*, 5
- Sustainability, 1–2, 49
 - achieving, 12–13
 - AWWA Groundwater Committee’s focus on, 261–263
 - and deforestation, 44
 - and distortions of natural cycles, 48
 - and effective resource utilization, 48
 - and evapotranspiration, 44, 45, 45*f.*
 - and land use changes, 44
 - and overpumping, 45
 - and precipitation patterns (US), 45, 45*f.*, 46*f.*
 - and quantity of water, 44–45
 - and reliability of available water, 44, 45–47, 45*f.*, 46*f.*
 - and runoff characteristics, 44
 - and source and supply of water, 44
 - systems (rules, laws, constraints), 48
 - and uncertainty and renewability of natural resources, 48
 - and water rights conflicts, 48
 - and water-level declines, 47–48, 47*f.*
- Sustainable yield, 12
- SWAPs. *See* Source Water Assessment Programs

- Temperature, 192
 - record keeping, 237

- Test wells, 95–96
 - information logs, 96–97
 - and stratigraphic log, 97
 - and USGS grain-size classification, 97, 97*t.*
- Theis nonequilibrium formula, 67–68, 125
- Theoretical cube, 51, 52*f.*
- Total dissolved solids (TDS), 197, 199
- Total dynamic head, 155
- Total head, 54–55
- Trace elements, 199
- Transmissivity, 8, 51
 - defined, 267
 - calculating, 62–64, 63*f.*, 64*f.*, 68
 - field testing, 65–67
 - ratios to well specific capacity, 124
 - and submergence, 125
- Transpiration, defined, 267
- Treatment. *See* Groundwater treatment
- Trihalomethanes (THMs), 201, 209

- Ultraviolet light, 211, 212*f.*
 - and hydrogen peroxide, 211, 211*f.*
 - and ozone, 211
- Underreaming, defined, 267
- Unsaturated zone, 6, 7*f.*
- Upconing, 16
- Uranium, 200
- US Environmental Protection Agency
 - and Groundwater Guardian Program, 37
 - Handbook for Groundwater and Wellhead Protection*, 38
 - and wellhead protection programs, 37
- US Geological Survey (USGS)
 - and Groundwater Guardian Program, 37
 - groundwater reports, 17
 - MODFLOW, 17, 127
 - rock and soil grain-size classification, 97, 97*t.*

- Velocity head, 135, 137*t.*
 - defined, 267
- Venice, Florida, 181
 - well field plugging and microbiological fouling (case study), 181–182, 182*f.*
- Venturi diffuser, defined, 267
- Vibrio cholerae*, 196
- Viruses, 196–197
- Viscosity, defined, 267
- Void space, defined, 267
- Volatile organic compounds (VOCs), 197, 200
 - treatment with packed-tower aerators (air strippers), 208, 209*f.*

- Water, distribution of, on earth, 2
- Water horsepower, 155–156
 - defined, 267
- Water marketing, 43
- Water quality. *See* Groundwater quality
- Water transfers, 43

- Water treatment. *See* Groundwater treatment
- Water wheeling, 43
- Waterborne illness, 36
- Well casings
 - for cable-tool drilled wells, 98–99
 - installation, 98–100
 - materials, 98, 99*t.*, 100*t.*
 - for rotary drilled wells, 99
 - special situations, 99–100
 - wall thickness, 100–101, 101*t.*, 102*t.*
- Well fields
 - design of, 123–125
 - determining pumping rates, 123–124
 - and interference between wells, 124–125, 124*f.*, 125*t.*
 - and ratios of transmissivity to well specific capacity, 124
- Well loss calculations, 125–127
- Well performance problems, 161–162
 - breaking suction, 164–166
 - cavitation, 164
 - clogged intake, 166
 - common operating problems, 164–166
 - corrosion, 167–168
 - and design and construction errors, 164
 - electro-chemical corrosion, 167–168
 - evaluation, 162–163
 - fouling, 162, 163
 - galvanic corrosion, 168
 - hydraulic corrosion, 167
 - iron and manganese plugging, 167
 - microbiological fouling, and treatment of, 169–174
 - operational conditions as indicators, 164
 - oxygen-cell corrosion, 167, 168
 - particulate plugging, 167
 - plugged wells (rehabilitation vs. replacement), 175–178, 176*f.*, 176*t.*, 177*f.*
 - and recommended production rate, 164
 - sand pumping, 163, 168–169, 169*f.*
 - silt and clay infiltration, 163
 - silt pumping, 163
 - specific capacity decrease, 163
 - water level decline, 163, 165–166, 165*f.*
 - well deterioration, physical causes of, 166–168
 - yield decrease, 163
- Well pumps and pumping
 - aboveground installation, 158
 - airlift, 151–152, 152*f.*, 152*t.*, 154*t.*
 - alignment, 158
 - axial flow, 149
 - best efficiency, 154
 - capacity, 135
 - centrifugal, 137–145, 144*f.*, 145*t.*, 154*t.*, 157
 - check valves, 159
 - classifications, 137–153, 154*t.*

- continuous running, 154
- deep-well installation, 158–159
- deep-well turbine, 146–147, 148*f.*, 154*t.*, 157, 159
- and demand, 155
- dynamic head, 135
- electric motor selection, 158
- electric motors, 156–157
- friction head, 135–136, 138*t.*–141*t.*, 142*t.*–143*t.*
- head loss, 136, 138*t.*–141*t.*, 142*t.*–143*t.*
- impulse, 151–153, 152*f.*, 152*t.*, 153*f.*, 154*t.*
- installation, 158–160
- jet, 152–153, 153*f.*, 154*t.*, 157
- mixed flow, 154*t.*, 159
- net positive suction head, 137
- operating conditions, 153–154
- operational limits, 157
- overall efficiency, 156
- performance measurement, 155–157
- pipng installation, 158
- power cost, 156–157
- power required, 156
- propeller, 149, 154*t.*
- pump selection, 155–157
- reciprocating (plunger), 145, 146*f.*, 154*t.*, 157
- record keeping, 230, 233*f.*, 234*f.*, 235, 235*f.*, 236*f.*
- rotary, 149, 154*t.*, 157
- rotary-displacement (positive-displacement), 149, 150*f.*, 154*t.*, 157
- rotary-gear, 149, 151*f.*, 154*t.*
- screw, 159
- spiral, 149
- starting and stopping, 153–154
- static head, 135, 136*f.*
- static suction head, 135
- submersible, 147, 154*t.*, 157, 160
- velocity head, 135, 137*t.*, 267
- Well screens, 101
 - aperture, defined, 266
 - and Bentonite grout, 109, 110–111
 - capacity, 107–108
 - and concrete sealing, 109
 - connection to well casing, 108
 - continuous-slot wire-wound type, 108
 - diameter of, 107, 122
 - and entrance velocity, 102–103, 105, 162–163
 - and gravel packs, 102, 104*f.*, 122
 - and gravel-pack installation, 106–107, 108
 - and gravel-pack materials, 105–106
 - and grout placement, 111–112
 - grouting and sealing materials, 108–112
 - and head loss, 103
 - information sources, 108
 - installation, 108
 - joints, 108
 - length of, 107
 - and limit of laminar flow, 104–105, 122
 - materials, 105
 - and neat cement, 109–110, 111
 - and sand-cement grouts, 109
 - selection, 102
 - slot size, 102–105, 103*f.*
 - slot size criteria, 107–108
 - and turbulent flow, 103–105
- Wellhead protection programs, 37
- Wells
 - in aquifer water-level measurements, 66–67
 - artesian, 8, 8*f.*, 265
 - bored, 80–81, 95*t.*
 - completion types, 117–118, 118*f.*–120*f.*
 - and cone of depression, 8, 9*f.*
 - decommissioning and abandonment, 187
 - design procedure, 122
 - development, 120–121
 - development records, 120–121
 - discharge piping, 120
 - disinfection, 122–123
 - and drawdown, 8
 - drilled, 82–90, 84*f.*, 85*f.*, 86*f.*, 87*f.*, 88*f.*, 95*t.*
 - drilling fluid materials, 97–98
 - driven, 81–82, 95*t.*
 - dug, 80, 81*f.*, 95*t.*
 - flowing artesian, 8, 266
 - gravel-wall, 90–91, 91*f.*
 - injection (Classes I–VI), 240–241
 - life-cycle cost (LCC) analysis of, 186–187
 - linking, 90
 - loss calculations, 125–127
 - performance evaluation, 162–163
 - preliminary development, 120
 - pumps in development of, 120, 121
 - radial, 92–93, 92*f.*, 95*t.*, 127
 - relocation from contaminated supply, 41, 42
 - and riverbank filtration, 93–94, 94*f.*
 - and sand content (in development), 120, 121*f.*
 - sanitary construction, 123
 - step-drawdown test for performance, 121
 - test wells, 95–97
 - types, 79–94, 95*t.*
 - water elevations in development of, 120
 - water-table, 7, 8*f.*
 - See also* Aquifer parameters; Aquifers; Groundwater; Record keeping
- Wenner array, 19–21, 20*f.*
- West Coast Basin Barrier Project (Southern California), 248
 - aquifer reclamation case study, 248–250, 251*f.*
- Withdrawals (formula), 12

This page intentionally blank.

AWWA Manuals

- M1, *Principles of Water Rates, Fees, and Charges*, #30001
- M2, *Instrumentation and Control*, #30002
- M3, *Safety Practices for Water Utilities*, #30003
- M4, *Water Fluoridation Principles and Practices*, #30004
- M5, *Water Utility Management*, #30005
- M6, *Water Meters—Selection, Installation, Testing, and Maintenance*, #30006
- M7, *Problem Organisms in Water: Identification and Treatment*, #30007
- M9, *Concrete Pressure Pipe*, #30009
- M11, *Steel Pipe—A Guide for Design and Installation*, #30011
- M12, *Simplified Procedures for Water Examination*, #30012
- M14, *Recommended Practice for Backflow Prevention and Cross-Connection Control*, #30014
- M17, *Installation, Field Testing, and Maintenance of Fire Hydrants*, #30017
- M19, *Emergency Planning for Water Utilities*, #30019
- M20, *Water Chlorination/Chloramination Practices and Principles*, #30020
- M21, *Groundwater*, #30021
- M22, *Sizing Water Service Lines and Meters*, #30022
- M23, *PVC Pipe—Design and Installation*, #30023
- M24, *Planning for the Distribution of Reclaimed Water*, #30024
- M25, *Flexible-Membrane Covers and Linings for Potable-Water Reservoirs*, #30025
- M27, *External Corrosion Control for Infrastructure Sustainability*, #30027
- M28, *Rehabilitation of Water Mains*, #30028
- M29, *Fundamentals of Water Utility Capital Financing*, #30029
- M30, *Precoat Filtration*, #30030
- M31, *Distribution System Requirements for Fire Protection*, #30031
- M32, *Computer Modeling of Water Distribution Systems*, #30032
- M33, *Flowmeters in Water Supply*, #30033
- M36, *Water Audits and Loss Control Programs*, #30036
- M37, *Operational Control of Coagulation and Filtration Processes*, #30037
- M38, *Electrodialysis and Electrodialysis Reversal*, #30038
- M41, *Ductile-Iron Pipe and Fittings*, #30041
- M42, *Steel Water-Storage Tanks*, #30042
- M44, *Distribution Valves: Selection, Installation, Field Testing, and Maintenance*, #30044
- M45, *Fiberglass Pipe Design*, #30045
- M46, *Reverse Osmosis and Nanofiltration*, #30046
- M47, *Capital Project Delivery*, #30047
- M48, *Waterborne Pathogens*, #30048
- M49, *Butterfly Valves: Torque, Head Loss, and Cavitation Analysis*, #30049
- M50, *Water Resources Planning*, #30050
- M51, *Air-Release, Air/Vacuum, and Combination Air Valves*, #30051
- M52, *Water Conservation Programs—A Planning Manual*, #30052
- M53, *Microfiltration and Ultrafiltration Membranes for Drinking Water*, #30053
- M54, *Developing Rates for Small Systems*, #30054
- M55, *PE Pipe—Design and Installation*, #30055
- M56, *Nitrification Prevention and Control in Drinking Water*, #30056
- M57, *Algae: Source to Treatment*, #30057
- M58, *Internal Corrosion Control in Water Distribution Systems*, #30058
- M60, *Drought Preparedness and Response*, #30060
- M61, *Desalination of Seawater*, #30061